

# Electrical Aspects of Fire Investigation



---

**Ray Franco**, PhD.,PE, Electrical Engineer

---

208 Fairways Dr.  
Vicksburg, MS 39183

601-529-7473  
ray@RayFranco.com

Electrical-Forensics.com elefor.com RayFranco.com



**Electrical-Forensics**  
*.com*

ray@RayFranco.com

601.529.7473

**Sitemap:**

<b>Appliances</b>	<b>Smoke Alarms</b>	<b>Lightning</b>	<b>Business</b>
Appliance Date Codes	Main Page Menu	Lightning Validation	Curriculum Vitae
Bimetal Thermostats		Lightning Damage	Rate Schedule
Heating Elements	<b>Wiring</b>		Evidence Storage Fees
Ranges	Loose Connections	<b>HVAC</b>	Deposition Agreement
Ovens	Meterbases	Air Conditioner Date Codes	Client Contract Agreement
Clothes Dryers	Circuit Breakers	Compressor Date Codes	Directions
Coffee Makers	Receptacles / Outlets	Air Conditioning	
Cable Clamps	Grounding		
Water Heaters	<b>Power</b>	<b>Miscellaneous</b>	
Air-Handler / Furnaces	Open Neutral	Animal Problems	
Lasko Fan Fire	Energized Neutral	NEC Violations	
Bathroom Fans	Distribution Lines	AWG Wire Sizes	
Ceiling Fans	Distribution Transformers	<b>References</b>	
Curling Irons	Transmission Poles	HVAC Links	
Electric Heaters	Transmission Arms	Motor Links	
Clothing Irons		Professional Links	
Voltage Surge Suppressors			

# NFPA 921

## GUIDE FOR FIRE AND EXPLOSION INVESTIGATIONS

- Considerable portion of this course is based on this “industry accepted guide”.
- Page 1: 2021 version: “This edition of NFPA 921 was approved as an **American National Standard** on April, 25 2025”
- NFA is not endorsing the document, however focus will be on Chapter 9 - *Electricity and Fire*.
- Failure to adhere to the document can result in an investigator's investigation and opinions being disallowed in a legal proceeding.

# Scientific Method

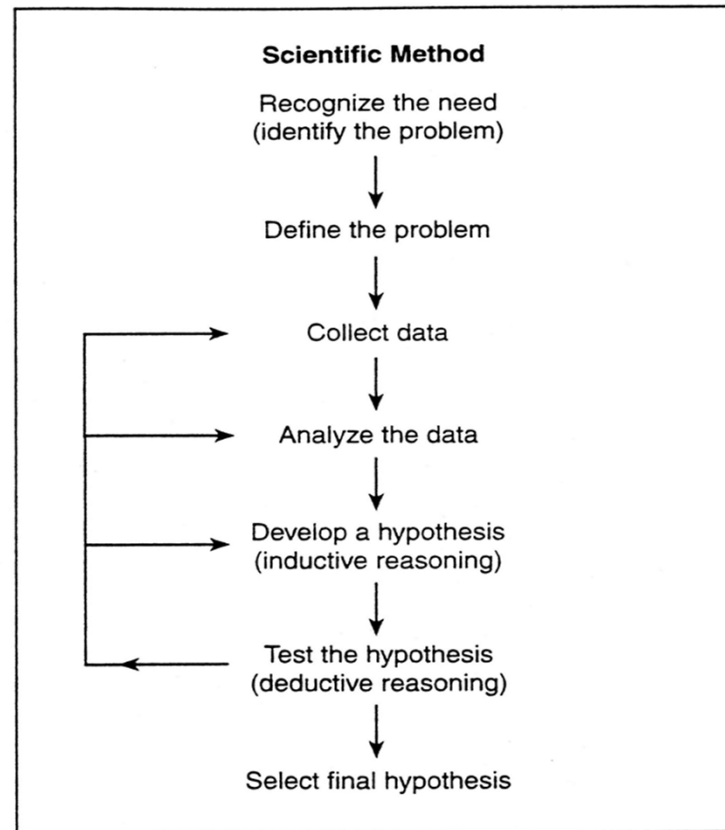



# Origin first ... then Cause

- Most important task of a fire investigator is to first identify the origin – Sometimes this may also be most difficult!
- In short, after the investigator identifies origin only then can we begin the task of cause.
- Investigators are much more likely to determine cause only when they have correctly identified the origin first!!



**1.3.7\*** The investigator shall have and maintain at a minimum an up-to-date basic knowledge of the following topics beyond the high school level:

- (1) Fire science
- (2) Fire chemistry
- (3) Thermodynamics
- (4) Thermometry
- (5) Fire dynamics
- (6) Explosion dynamics
- (7) Computer fire modeling
- (8) Fire investigation
- (9) Fire analysis
- (10) Fire investigation methodology
- (11) Fire investigation technology
- (12) Hazardous materials
- (13) Failure analysis and analytical tools
- (14) Fire protection systems*
- (15) Evidence documentation, collection, and preservation*
- (16) Electricity and Electrical Systems***

# Spoliation

**Defined:** Loss, destruction, or material alteration of an object or document that is evidence or potential evidence in a legal proceeding by one who has the responsibility for its preservation.  
(NFPA 921)

**Repercussions:**

- Sanctions
  - ✓ Dismissal of claims or defenses,
  - ✓ Preclusion of evidence, and the
  - ✓ Granting of summary judgment for the innocent party.

# Spoliation

## **DO NOT:**

- ✓ Take “Trophies” or Souvenirs.... its stealing!!
- ✓ Destroy contents without reason
- ✓ Take appliances / devices / evidence apart
- ✓ Demolish the structure unless there is a life safety issue!  
(Extinguishment of Fire vs. Nuisance)

# BASIC TERMS

Just like in every other aspect of fire investigations, there are terms and principals that need to be understood.

For some these will be new, and others this will be a refresher.

# VOLTAGE (VOLTS)

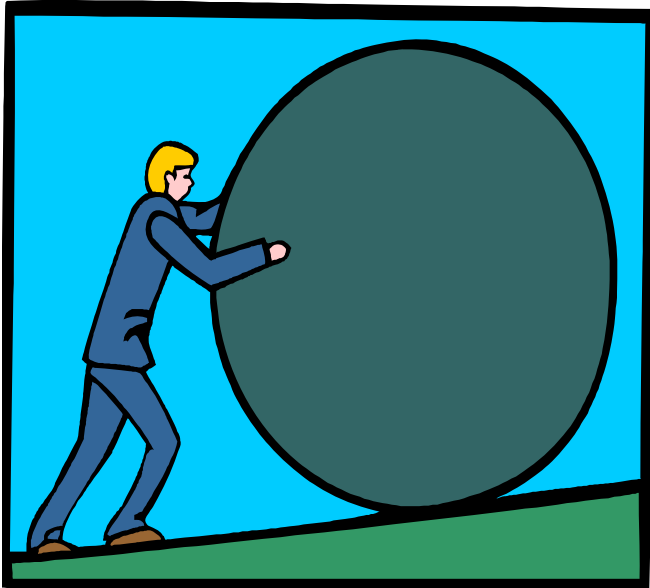

- Electrical pressure that moves the electrons through the conductor
- Also known as Electromotive Force (EMF)

$E = \text{Volts}$

**Volts is the potential difference between two points.**

# CURRENT (AMPERE)



Is the rate at which electrons flow through a conductor. It is determined by measuring the amount of electrons flowing past a single point in one second.

**I = Ampere or Amp**

# RESISTANCE (OHMS)

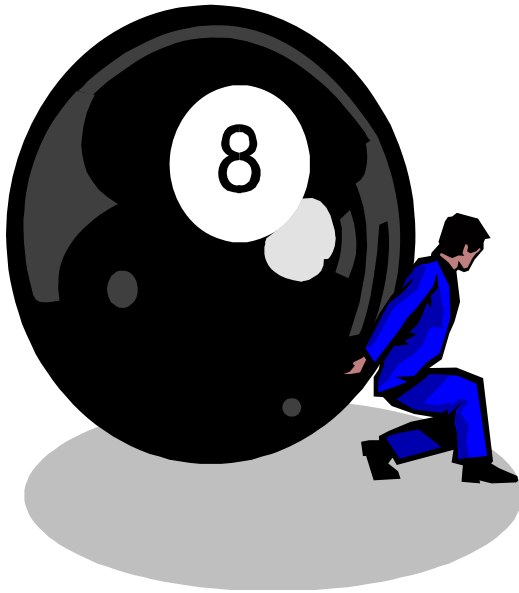

This is the opposition to current flow.

Measured in Ohms

Greek Symbol Omega

$$\Omega = R$$



# RESISTANCE (OHMS)

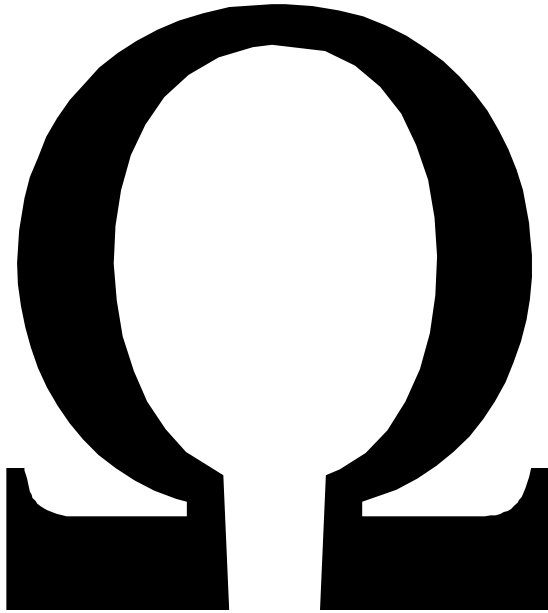

- When current flows through any resistance, heat is always generated. Every conductor offers some resistance.
- Every splice/connection in a circuit creates some resistance.
- Excessive resistance can create high temperatures.

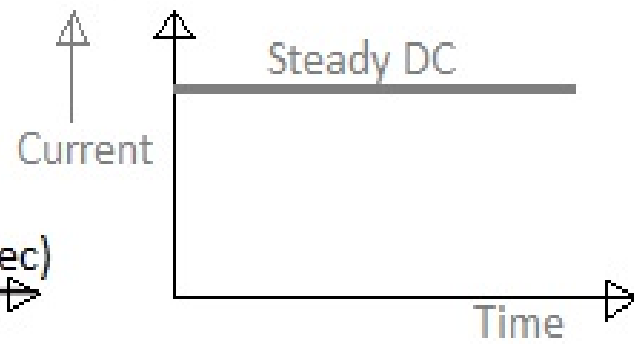
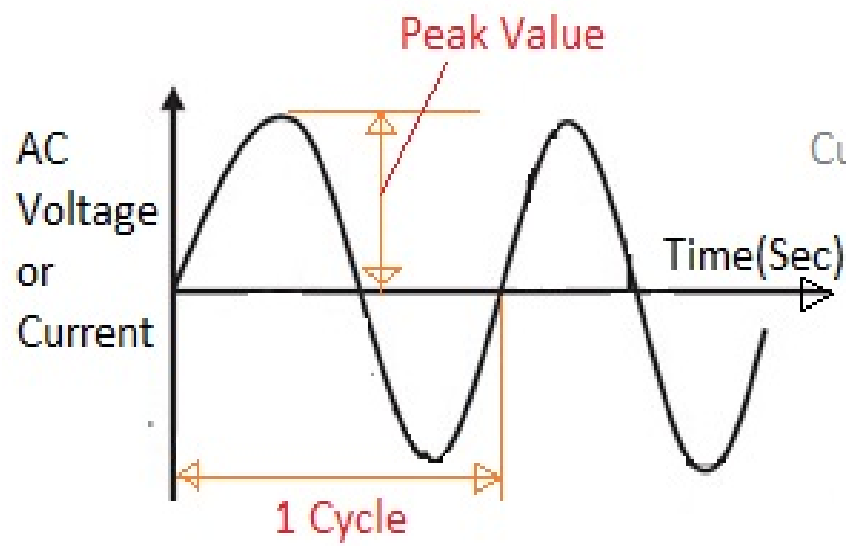

AC vs DC

## WHAT CAUSES THE ELECTRONS TO MOVE: MAGNETISM

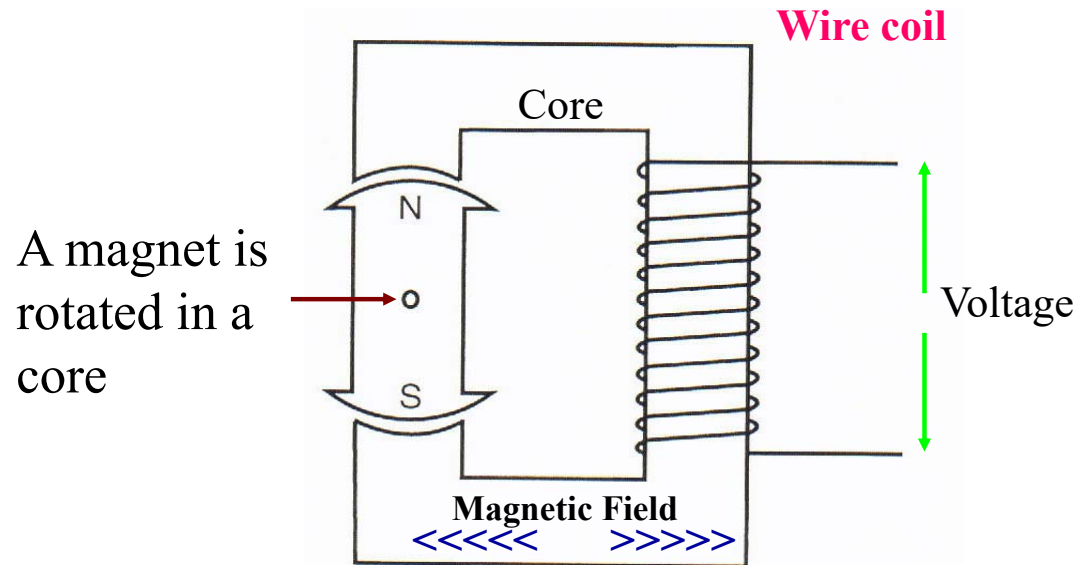

As the magnet is rotated it creates a field in the core.  
This field is strongest as the magnet is aligned vertically as shown.  
When the magnet is rotated to horizontal the field is decreasing to zero.  
The field reverses and increases as the magnet continues to rotate.  
This increasing, decreasing and reversing field creates a voltage potential in the coil. The voltage waveform is a sine wave, this is how A/C or alternating current is generated.

- What in a home uses AC Power?
- Answer - Anything that generates heat or has a motor: Cooktops, Ranges, Dryer, Refrigerator, Air Conditioners.
  
- What in a home uses DC Power?
- Answer - Anything that is electronic.
  
- What is a DC Power Supply?
- Answer – A device that converts AC Power to DC Power. DC Power Supplies output a specified voltage and wattage. You can not run your laptop from a cell phone charger.

# OHM'S LAW

Ohm's Law was named after Georg Simon Ohm (1787-1854).

Ohm's Law is stated as:

"The amount of current flowing in a circuit made up of pure resistance is directly proportional to the electromotive forces impressed on the circuit and inversely proportional to the total resistance of the circuit."

# BASIC OHM'S LAW

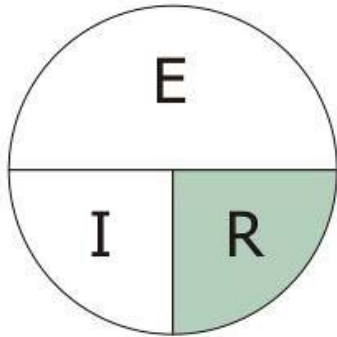

$$R = \frac{E}{I}$$

Resistance = Voltage  $\div$  Current

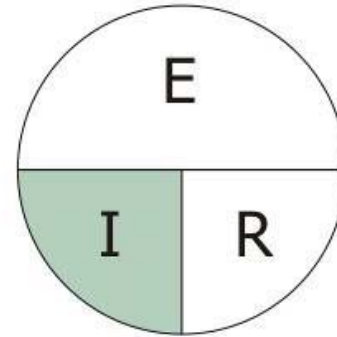

$$I = \frac{E}{R}$$

Current = Voltage  $\div$  Resistance

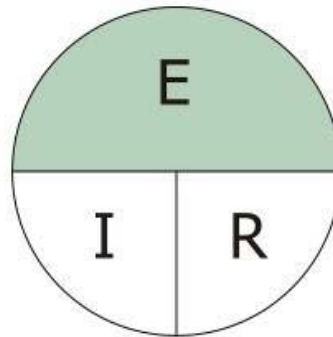

$$E = I \times R$$

Voltage = Current  $\times$  Resistance

# JOULE'S LAW

James Prescott Joule (1818-1889) formulated a relationship between the heat generated in an electric wire and the voltage across and current through that wire.

# JOULE'S LAW

$$P \text{ (watts)} = E \text{ (volts)} \times I \text{ (current)}$$

$$E \text{ (volts)} = P \text{ (watts)} / I \text{ (current)}$$

$$I \text{ (current)} = P \text{ (watts)} / E \text{ (volts)}$$



Ohm's/Watt's Wheel (2021 NFPA921 p125)

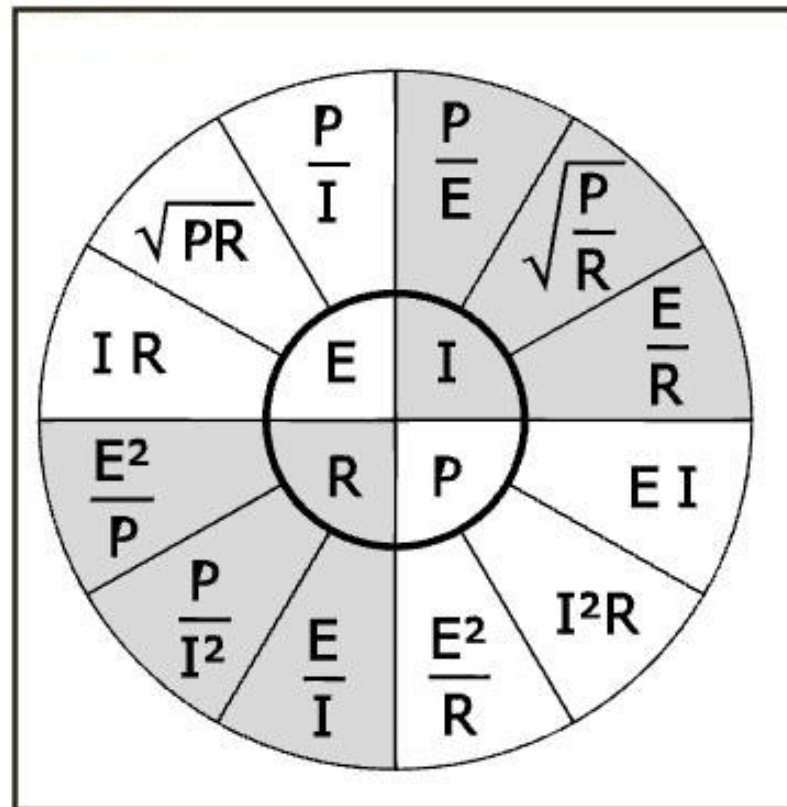

E = voltage I = current  
R = resistance P = power

www.ohmslawcalculator.com

## Ohm's Law Calculator

*Voltage (V) = Current (I) \* Resistance (R)*

*Power (P) = Voltage (V) \* Current (I)*

Enter any two known values and press "Calculate" to solve for the others.

Voltage (V)

Volts (V)

Current (I)

amps (A)

Resistance (R)

ohms ( $\Omega$ )

Power (P)

Watts (W)

Calculate

Click "Calculate" to update the fields with orange borders.

Burned Coffeemaker





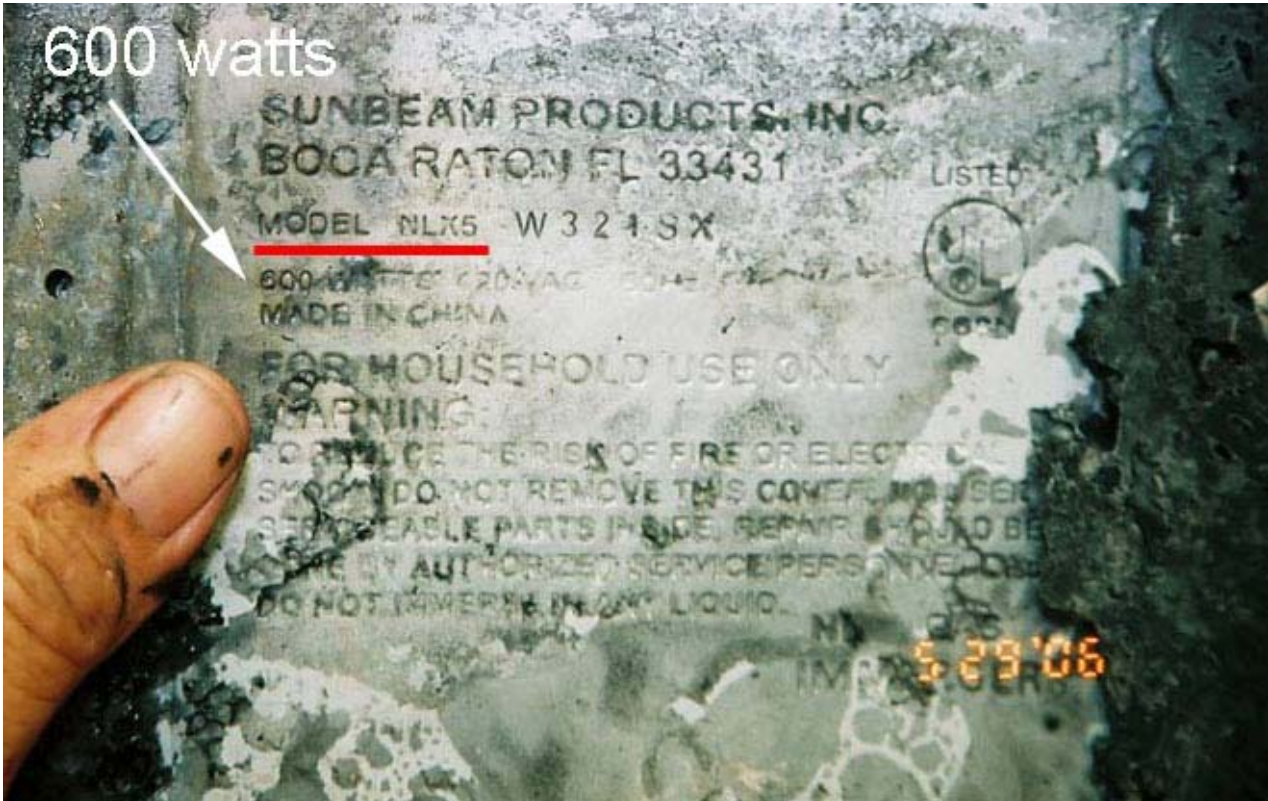

600 watts

SUNBEAM PRODUCTS, INC.

BOCA RATON, FL 33431

LISTED

MODEL NLK5 W 3 2 1 S X

600 WATTS 120VAC 50/60Hz

MADE IN CHINA



FOR HOUSEHOLD USE ONLY

WARNING:

TO REDUCE THE RISK OF FIRE OR ELECTRICAL SHOCK, DO NOT REMOVE THIS COVER, NO USER SERVICEABLE PARTS INSIDE. REPAIR SHOULD BE DONE BY AUTHORIZED SERVICE PERSONNEL ONLY. DO NOT IMMERSE IN ANY LIQUID.

5:29:06

www.ohmslawcalculator.com

## Ohm's Law Calculator

*Voltage (V) = Current (i) \* Resistance (R)*

*Power (P) = Voltage (V) \* Current (i)*

Enter any two known values and press "Calculate" to solve for the others.

Voltage (V)

120

Volts (V)

Current (i)

current

amps (A)

Resistance (R)

resistance

ohms ( $\Omega$ )

Power (P)

600

Watts (W)

Coffeemaker

Calculate

Click "Calculate" to update the fields with orange borders.

www.ohmslawcalculator.com

## Ohm's Law Calculator

*Voltage (V) = Current (I) \* Resistance (R)*

*Power (P) = Voltage (V) \* Current (I)*

Enter any two known values and press "Calculate" to solve for the others.

Voltage (V)

Volts (V)

Current (I)

amps (A)

Resistance (R)

ohms ( $\Omega$ )

Power (P)

Watts (W)



Calculate

Click "Calculate" to update the fields with orange borders.



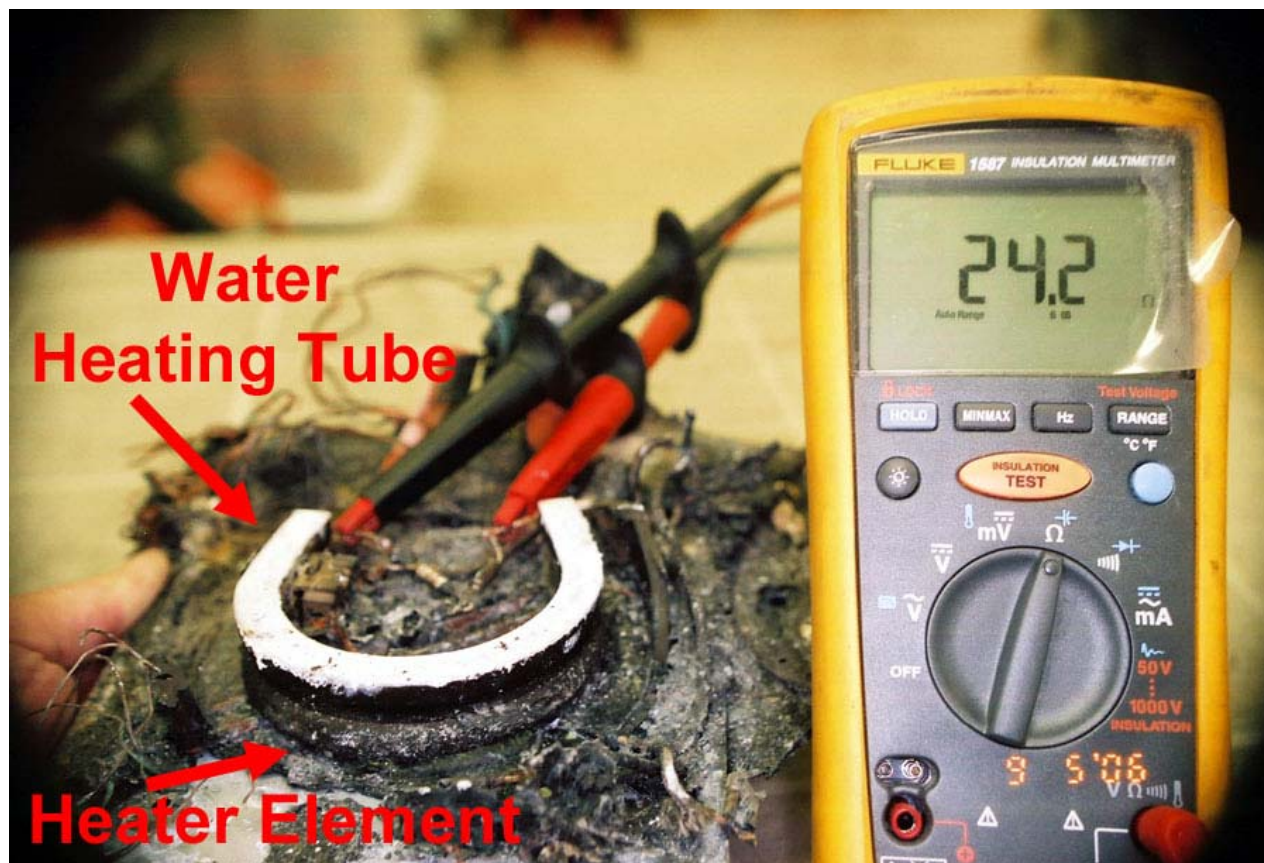

HOME APPLIANCE	WATTAGE*	HOME APPLIANCE	WATTAGE*
Broiler	1,400	Central Air Conditioning	2,000-4,000
Refrigerator / Freezer	600-800	Coffeemaker	400-800
Electric Furnace	5,000-25,000	Electric Range (oven only)	5,000
Electric Range (one element)	2,500	Hair Dryer	1,200-1,500
Table Lamp (tri-lite)	150	Sump Pump	1,500
Television	100-350	Vacuum	700-1,400
Heater (radiant)	1,300	Space Heater	1,250
Toaster	1,100-1,700	Water Heater	3,000-4,500
Microwave	1,200	Water Pump	1,000-2,000
Hot Plate	1,250	Window Air Conditioner	600-1,500
Outdoor Lighting	500-1,000	Personal Computer	500-2,000



## Mobile Home Fire – Investigated by the Sheriff's Department







# Incident Narrative

- “I then went and examined the area that showed the most significant fire damage to find the cause and origin of the fire.”
- “Power to the home was restored, and I continued searching this area when I begin detecting smoke in the area where none had been previously.”
- “I then attempted to remove a bolt that appeared to have an odd rust color. I attempted to remove it bare handed, and it shocked me causing me to jerk my hand back.”



# Incident Narrative Continued

- “I then reported this to on scene firefighters, and Chief ---- also saw the bolt in question.”
- Power was disconnected.
- “Chief --- stated that the ground wire to the Direct TV satellite disks appeared to be connected to the metal under the home.”
- “I then waited until the bolt had sufficiently cooled down after I was informed by the on scene firefighters that the bolt in question looked to be glowing red with heat as a result of power returning to it.”

## Incident Narrative Continued

- He removed the bolt and it had loose rust on it.
- “I personally have seen a similar process called electrolysis in which electricity is used to remove rust from a metal object.”
- “It is believed at this time that due to the significant shock that I experienced from it as well as the rust being knock loose that the bolt had a significant amount of electricity coursing through it possibly coming from the satellite disk; they were the only electrical items near that section of the home.
- “It is believed at this time that the fire is electrical in nature and the cause and origin of the fire being the bolt acting as a source of heat cannot be ruled out at this time.”

BOBYCAM



01/23/2023-18:37:33L 9J00410 JMAHER

- Does a satellite dish use AC or DC power?
- Answer – There is a pre-amplifier in the satellite dish that uses DC power.
  
- Is the voltage high enough that you will feel electricity flowing through your body?
  
- Is the power enough that it can raise the temperature of a steel bolt to make it glow?



Coax —  
Ground —

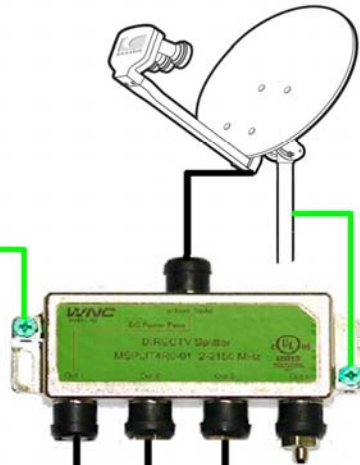

4-Way SWM Splitter  
MSPLIT4R1-02

Power Inserter (PI)  
21 VDC



Genie  
12 VDC

Genie Mini  
12 VDC



Genie Mini  
12 VDC





# DIRECTV

POWER INSERTER

MODEL : PI21R3-16

FREQ. RANGE : 2-2150 MHz

INSERTION LOSS : 1.5 dB typ.

INPUT: 120 V ~ 0.6 A 60Hz

OUTPUT : 21 V  $\equiv$  1.2 A max / 25.2 W max

EFFICIENCY LEVEL : VI

CAUTION: INDOOR USE ONLY

Precaucion: para uso interior solamente

- Electricity does not just flow through a bolt; it has to have path. Assuming that the bolt was in the sheet metal, he should have received an electrical shock when he touched the sheet metal.
- Will 21 volts shock you? NFPA 921 wants you to test your hypothesis. For the human body to feel electrical current following through it, the voltage has to be greater than 48 volts. This is the reason that golf cart and recreational vehicles are limited to 48 volts.
- Can 25.2 watts raised the temperature of bolt enough that it glows? An appliance light bulb such as in a refrigerator or dryer is around 30 watts. For a metal object to have a faint red glow requires that it be raised to a temperature around 900 degrees Fahrenheit (Wikipedia).
- No sign of overheating in the direct TV wires.

**Bussmann®**



**COOPER** Bussmann

**Handbook for Electrical Safety**

## Electrical Safety

1 mA = 1/1,000 amp

Current (60 Hz)	Physiological phenomena	Feeling or lethal incidence
<1 mA	None	Imperceptible
1 mA	Perception threshold	Mild sensation
1-3 mA		Painful sensation
3-10 mA		
10 mA	Paralysis threshold of arms	Cannot release hand grip; if no grip, victim may be thrown clear (may progress to higher current and be fatal)
30 mA	Respiratory paralysis	Stoppage of breathing (frequently fatal)
75 mA	Fibrillation threshold 0.5%	Heart action discoordinated (probably fatal)
250 mA	Fibrillation threshold 99.5% (≥ 5-s exposure)	
4 A	Heart paralysis threshold (no fibrillation)	Heart stops for duration of current passage. For short shocks, may restart on interruption of current (usually not fatal from heart dysfunction)
≥5 A	Tissue burning	Not fatal unless vital organs are burned

- 27 volt battery demo

**Table II. Human Resistance Values for Various Skin-contact Conditions**

Condition	Resistance, (ohms)	
	Dry	Wet
Finger Touch	40,000 to 1,000,000	4,000 to 15,000
Hand Holding Wire	15,000 to 50,000	3,000 to 6,000
Finger-Thumb Grasp	10,000 to 30,000	2,000 to 5,000
Hand Holding Pliers	5,000 to 10,000	1,000 to 3,000
Palm Touch	3,000 to 8,000	1,000 to 2,000
Hand Around 1 1/2 Pipe	1,000 to 3,000	500 to 1,500
Two Hands Around 1 1/2 Pipe	500 to 1,500	250 to 750
Hand Immersed		200 to 500
Foot Immersed		100 to 300
Human Body, Internal, Excluding Skin	200 to 1,000	

*This table was compiled from data developed by Kouwenhoven and Milnor.*



## Ohm's Law Calculator

*Voltage (V) = Current (i) \* Resistance (R)*

*Power (P) = Voltage (V) \* Current (i)*

Enter any two known values and press "Calculate" to solve for the others.

Voltage (V)

Volts (V)

Current (i)

amps (A) ▼

Resistance (R)

ohms ( $\Omega$ ) ▼

Power (P)

Watts (W)

Calculate

Click "Calculate" to update the fields with orange borders.

## Ohm's Law Calculator

$$\text{Voltage (V)} = \text{Current (I)} * \text{Resistance (R)}$$

$$\text{Power (P)} = \text{Voltage (V)} * \text{Current (I)}$$

Enter any two known values and press "Calculate" to solve for the others.

Voltage (V)

Volts (V)

Current (I)

amps (A) ▼

Resistance (R)

ohms ( $\Omega$ ) ▼

Power (P)

Watts (W)

Calculate

Click "Calculate" to update the fields with orange borders.

# Electricity generation, transmission, and distribution

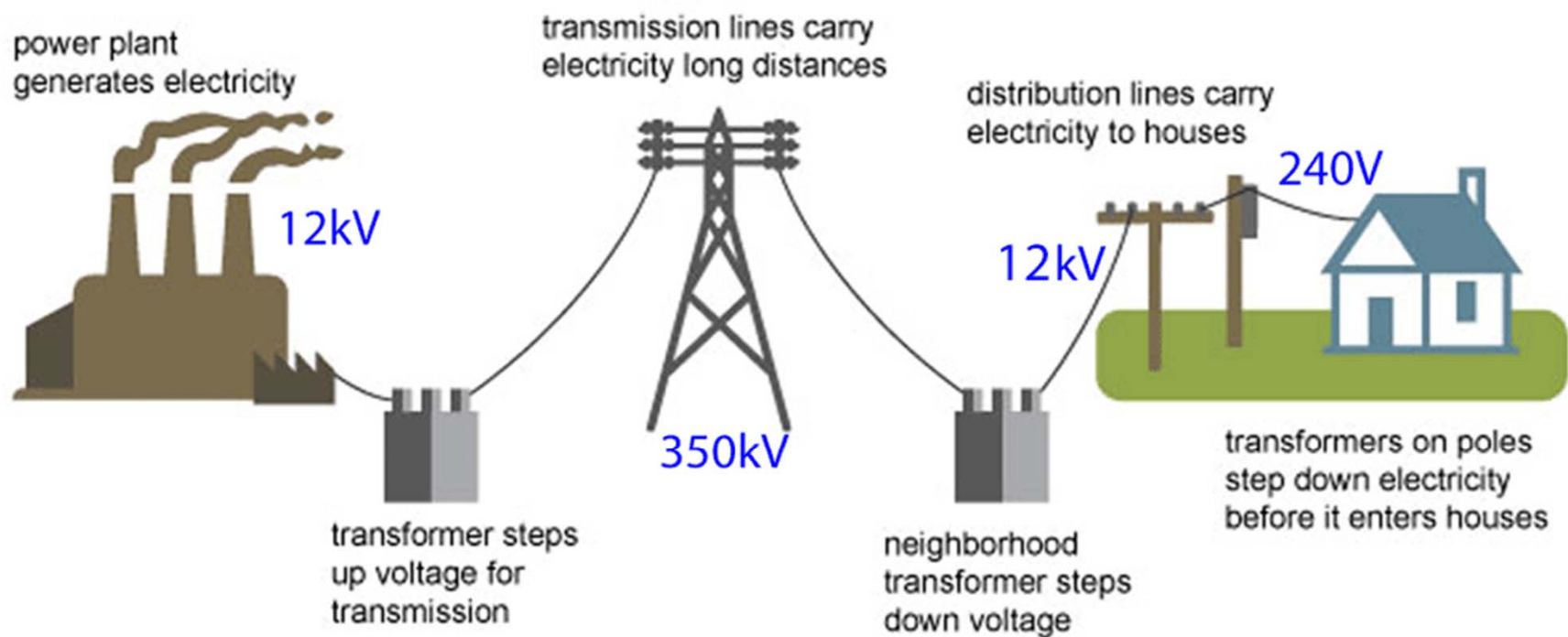

Source: Adapted from National Energy Education Development Project (public domain)

# TRANSFORMERS

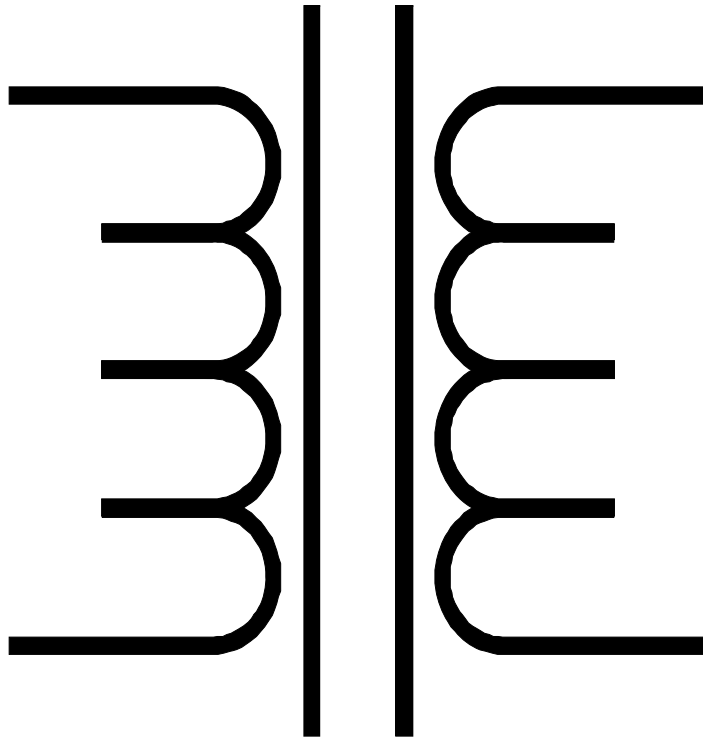

- Used to step AC voltage up or down. DC can be increased or decreased but not with a transformer.
- AC can be rectified to act like DC and supply one way current.
- DC can not be transformed.

# TRANSFORMERS

- Used to increase or decrease voltage.
- Consists of two isolated coils of wire around an iron core.
- **Primary coil** is the input voltage coil.
- **Secondary coil** is the output voltage coil.

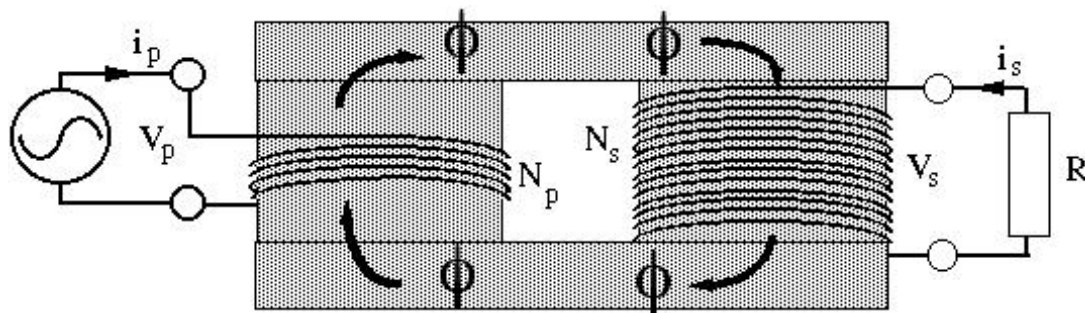

# TRANSFORMERS

- Ratio of coil turns determines voltage change

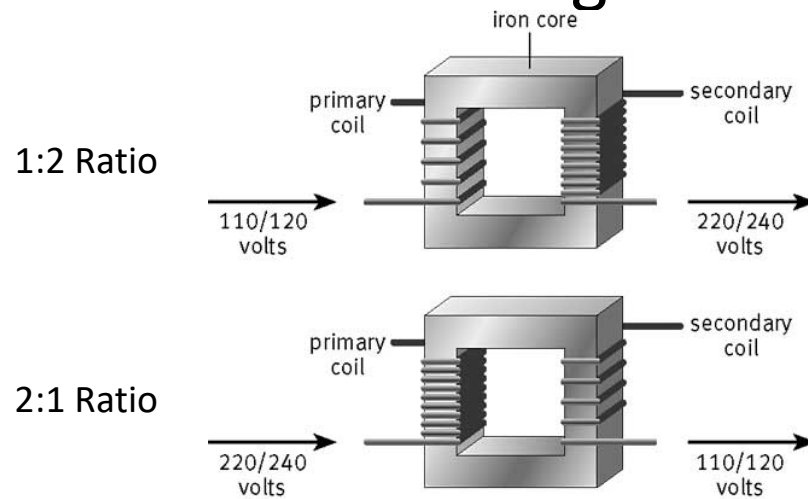

# TRANSMISSION LINES

Typical transmission voltages between power generators and sub stations are 69,000, 138,000, 345,000, 500,000, and 1,100,000.



138,00 volts exist between wires

**DANGER:  
THESE  
WIRES  
ARE NOT  
INSULATED**

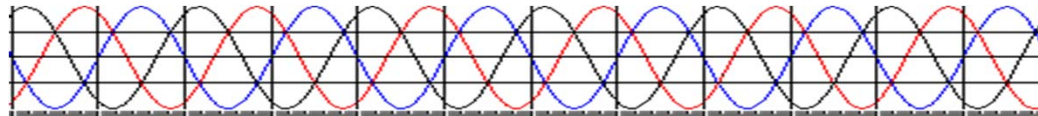

Notice the tower on the right has three wires. This is a three phase, A/C system. Each wire carries a sinusoidal voltage wave 120° out of phase from the others. The color graph above shows three sinusoidal waveforms over time.



# SUBSTATIONS





- Why do we use transformers?
- The amount of current that can safely flow in a wire without overheating is directly proportional to the diameter of the wire.
  
- For a 120 volt, 12,000 watt furnace, how much current does it draw?
- Answer –  $12,000/120 = 100$  amps
  
- For a 240 volt, 12,000 watt furnace, how much current does it draw?
- Answer  $12,000/240 = 50$  amps
  
- 12,000 volt, 12,000 watt furnace draws:  $12,000/12,000 = 1$  amp.

## Ohm's Law Calculator For a 12,000 Watt Furnace

$$\text{Voltage (V)} = \text{Current (I)} * \text{Resistance (R)}$$

$$\text{Power (P)} = \text{Voltage (V)} * \text{Current (I)}$$

Enter any two known values and press "Calculate" to solve for the others.

Voltage (V)

Volts (V)

Current (I)

amps (A) ▼

Resistance (R)

ohms ( $\Omega$ ) ▼

Power (P)

Watts (W)

Calculate

Click "Calculate" to update the fields with orange borders.

## Ohm's Law Calculator

$Voltage (V) = Current (i) * Resistance (R)$

$Power (P) = Voltage (V) * Current (i)$

Enter any two known values and press "Calculate" to solve for the others.

Voltage (V)

Volts (V)

Current (i)

amps (A) ▾

Resistance (R)

ohms ( $\Omega$ ) ▾

Power (P)

Watts (W)

Calculate

Click "Calculate" to update the fields with orange borders.

## Ohm's Law Calculator

*Voltage (V) = Current (i) \* Resistance (R)*

*Power (P) = Voltage (V) \* Current (i)*

Enter any two known values and press "Calculate" to solve for the others.

Voltage (V)

Volts (V)

Current (i)

amps (A) ▼

Resistance (R)

ohms ( $\Omega$ ) ▼

Power (P)

Watts (W)

Calculate

Click "Calculate" to update the fields with orange borders.

## Ohm's Law Calculator

*Voltage (V) = Current (i) \* Resistance (R)*

*Power (P) = Voltage (V) \* Current (i)*

Enter any two known values and press "Calculate" to solve for the others.

Voltage (V)

Volts (V)

Current (i)

amps (A) ▾

Resistance (R)

ohms (Ω) ▾

Power (P)

Watts (W)

Calculate

Click "Calculate" to update the fields with orange borders.

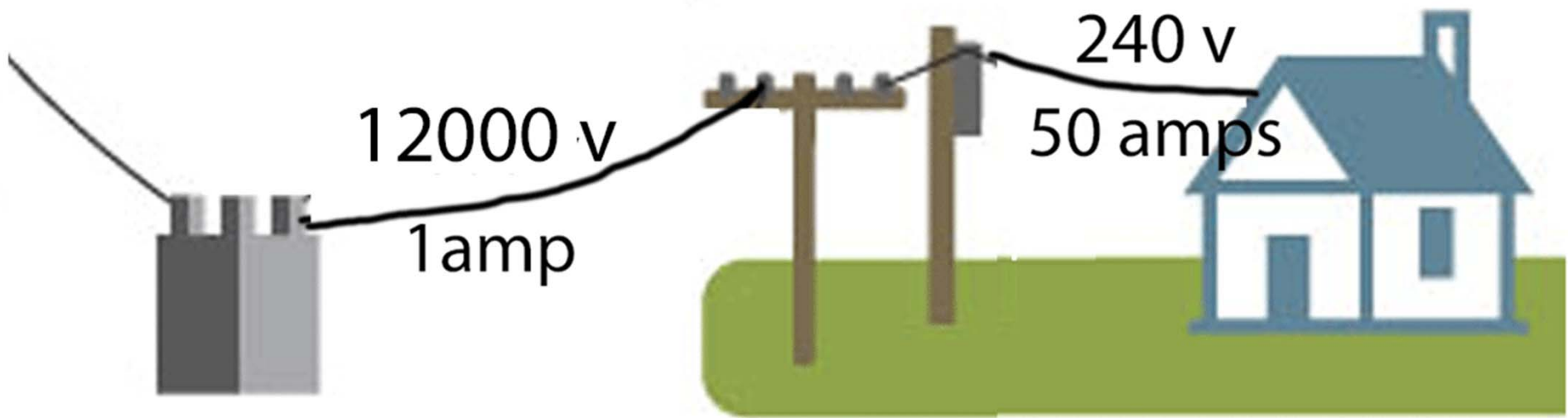

Assume the resistance of the distribution line is 1 ohm.  
What is the voltage drop across the distribution line?

$$E = I * R = 1 * 1 = 1 \text{ volt.}$$

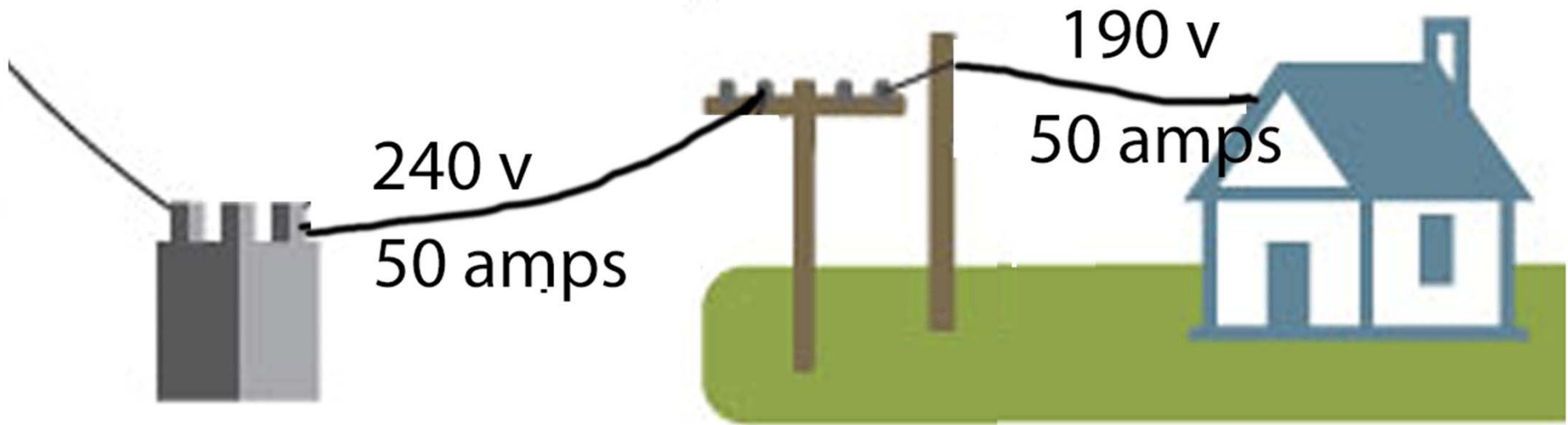

Assume the resistance of the distribution line is 1 ohm.  
What is the voltage drop across the distribution line?

$$E = I * R = 50 * 1 = 50 \text{ volts} \quad \text{---} \quad 240 - 50 = 190$$

- Entergy Arc and Spark Show



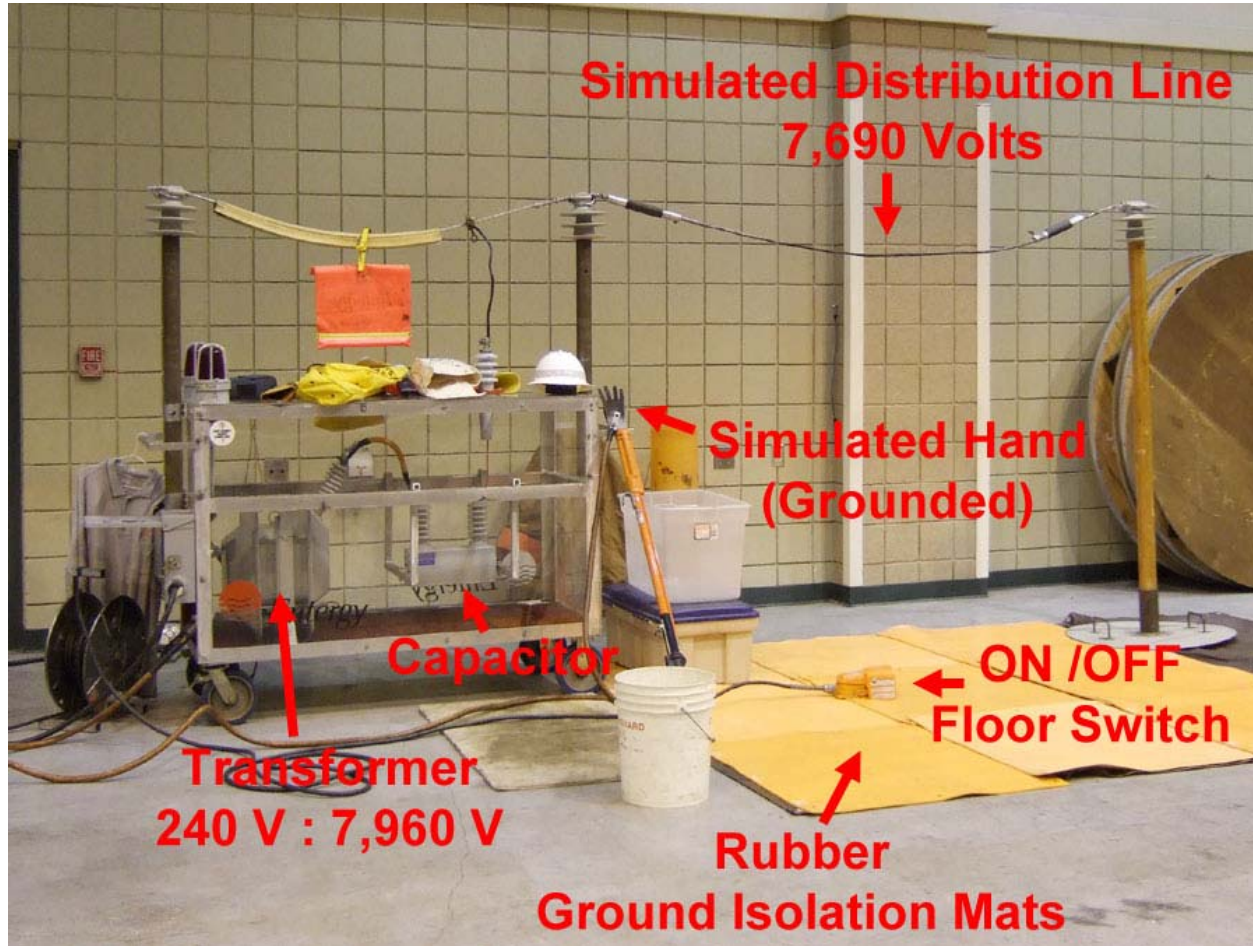

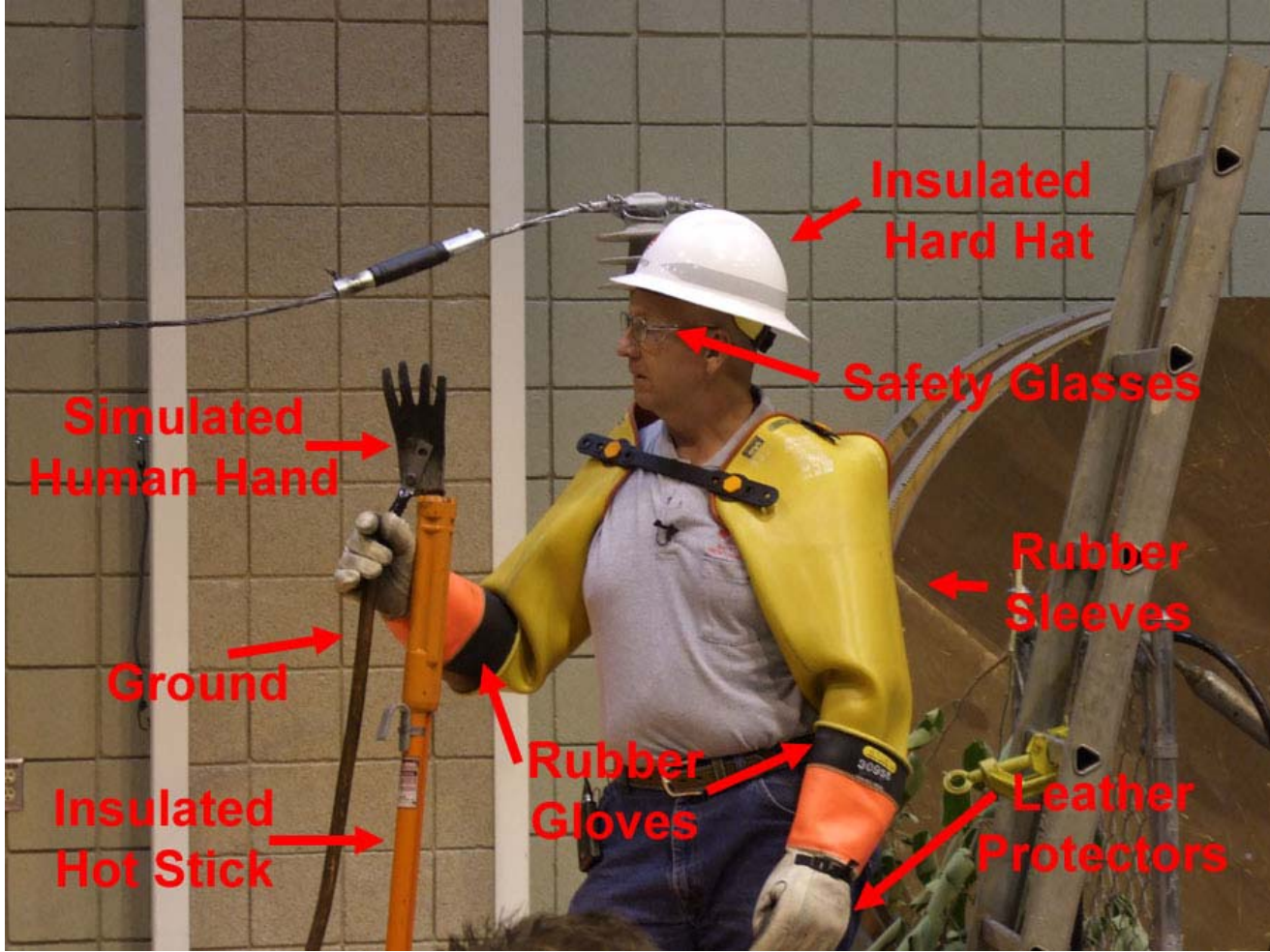

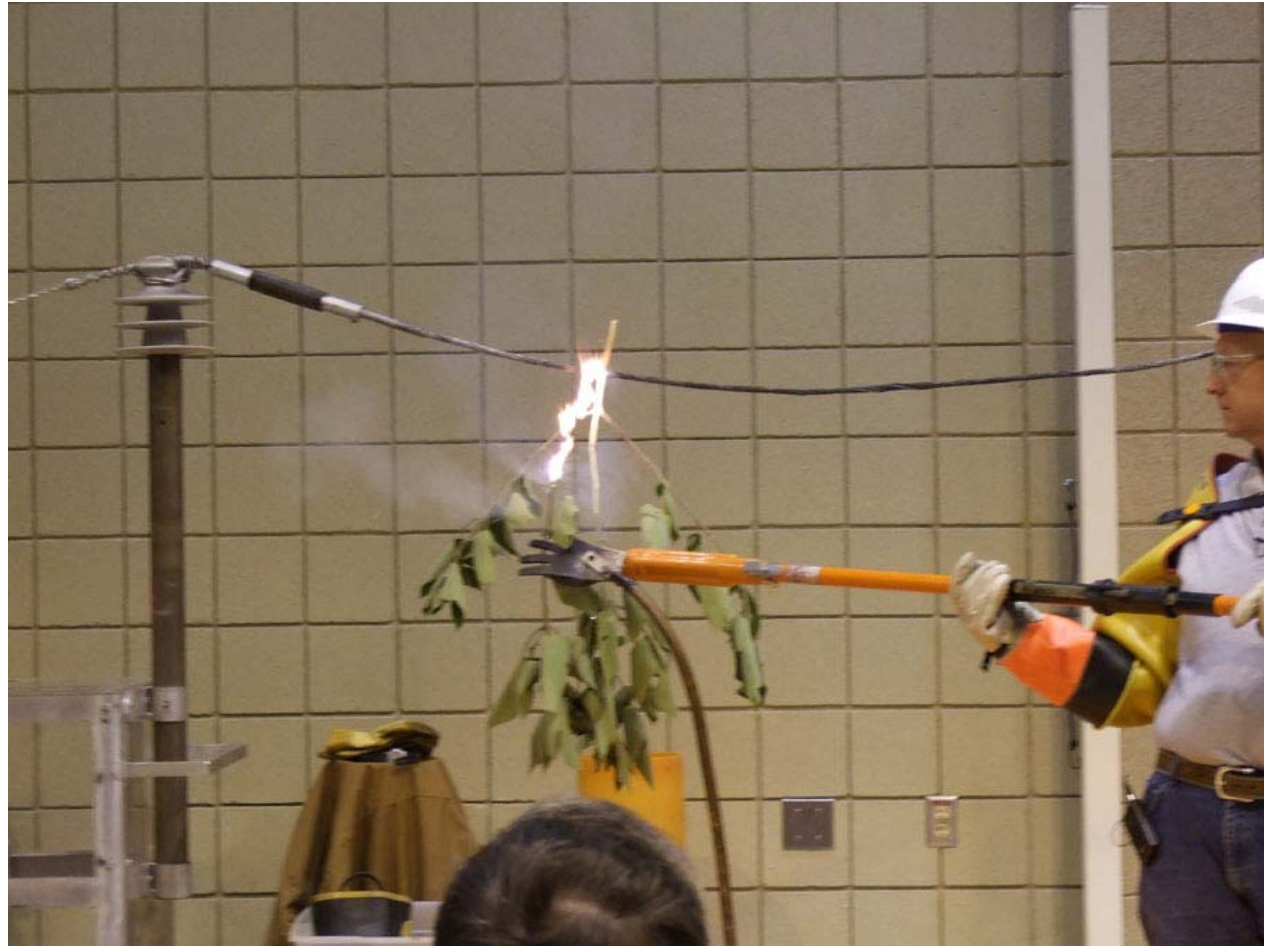









Firefighter's Pike Pole

# THREE PHASE POWER

- Used in larger occupancies where lighting and motor loads are greater than a residential occupancy.
  - Motors are less costly, and run more efficiently.
- Higher Voltage = Less amperage to deliver the same amount of energy (Joule's Law) and therefore allows the use of smaller size conductors.
  - Common Three Phase system voltages are:  
120/240 with a 208 "High Leg"- Orange in Color / B Phase  
120/208  
277/480

# THREE PHASE

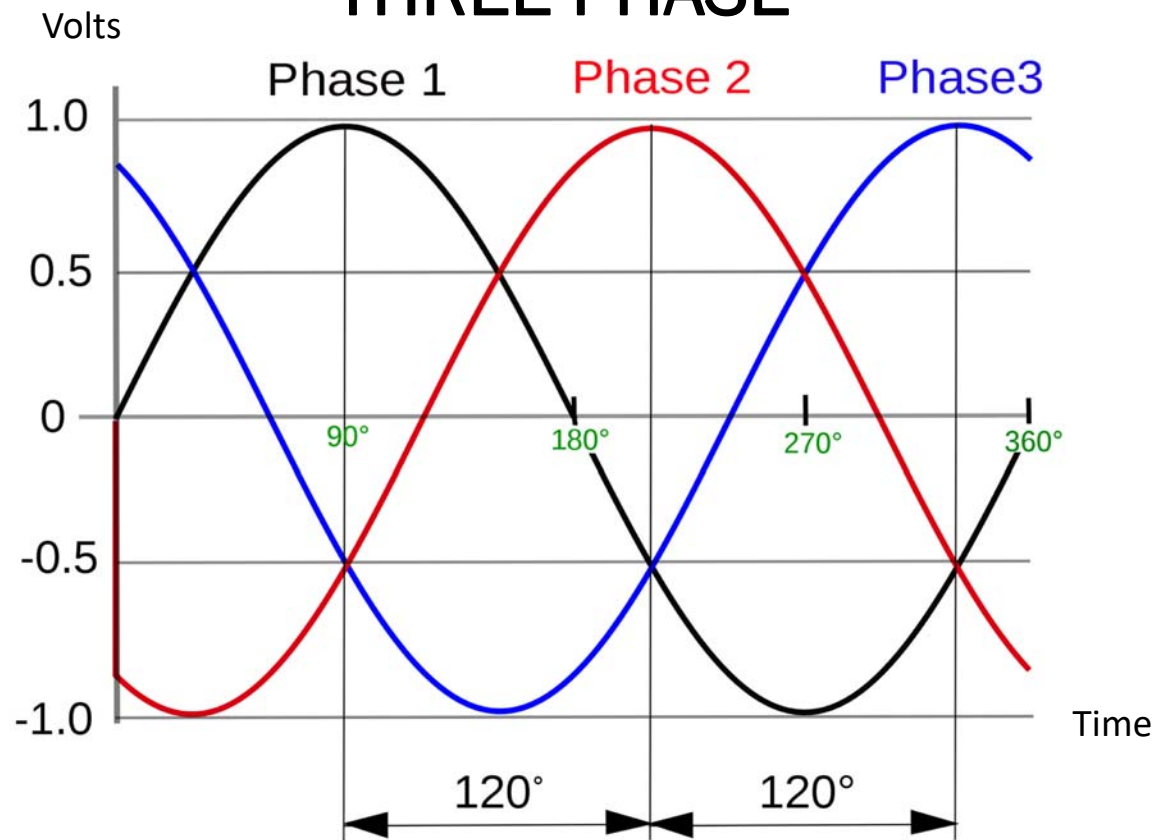





**Typical three  
phase assembly**

**12kv 3-Phase**

**8 kv 1-Phase**

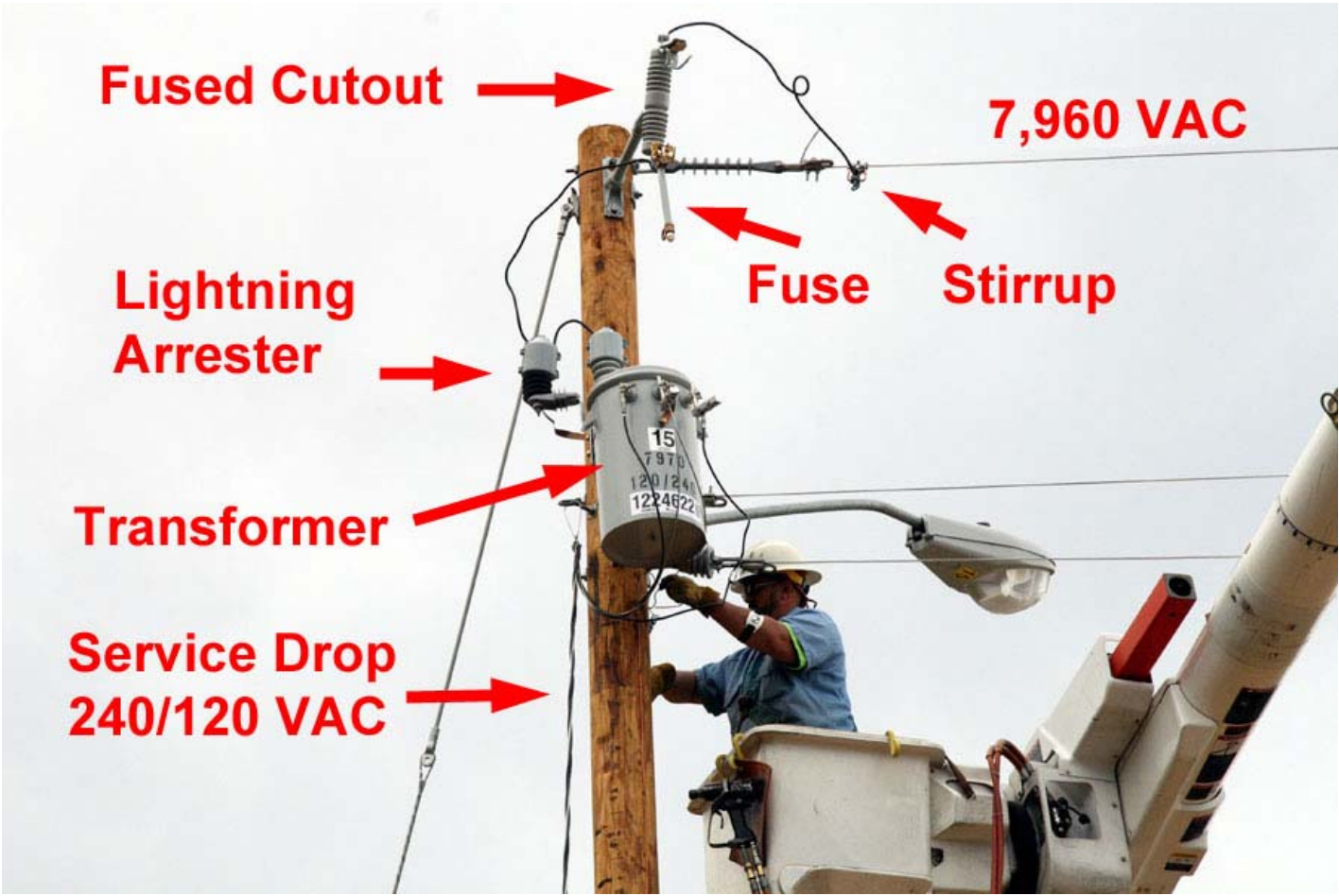

# ELECTRICITY DISTRIBUTION

- Pad mounted transformer
- Can be single or three phase
- Accompanied by underground lateral



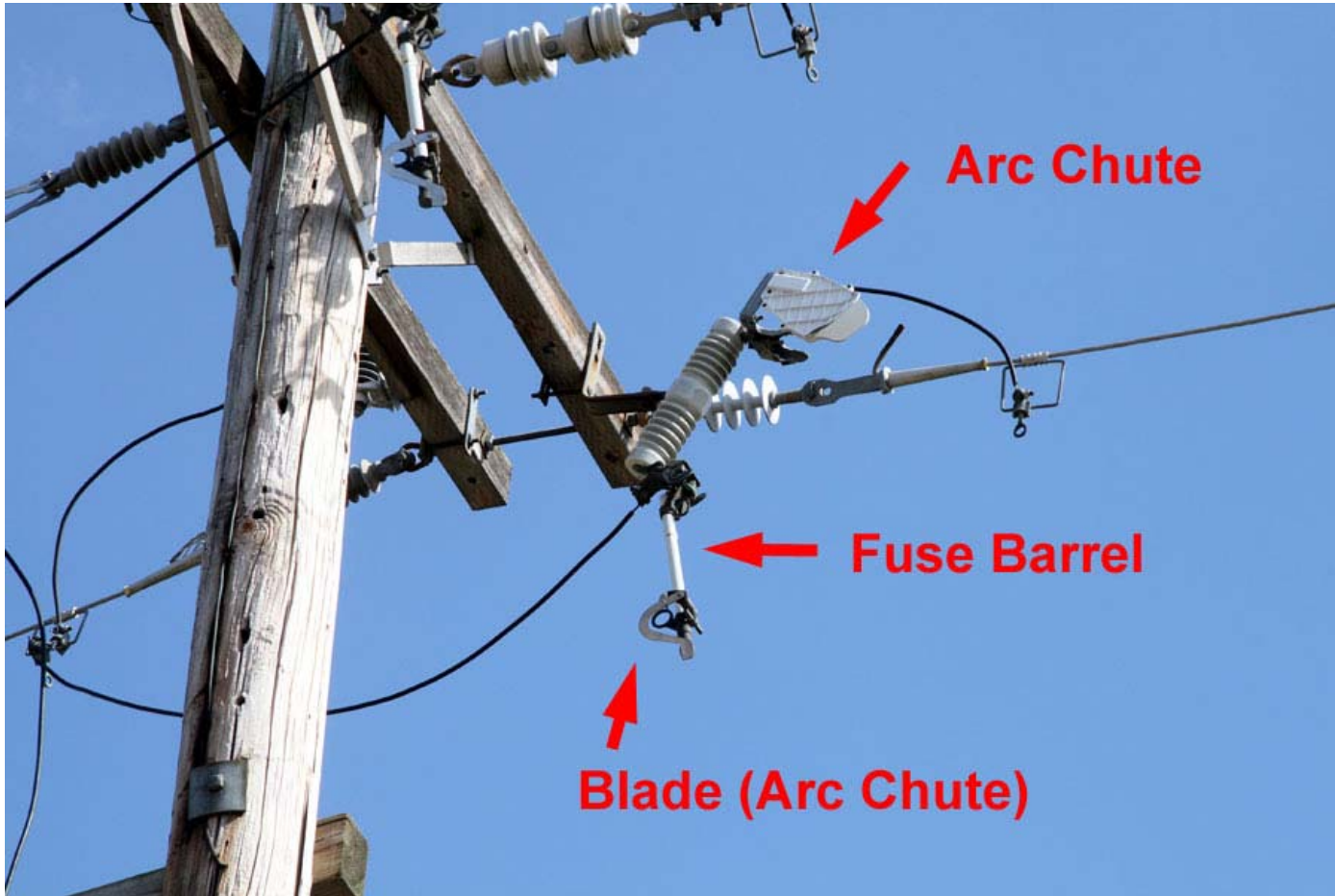



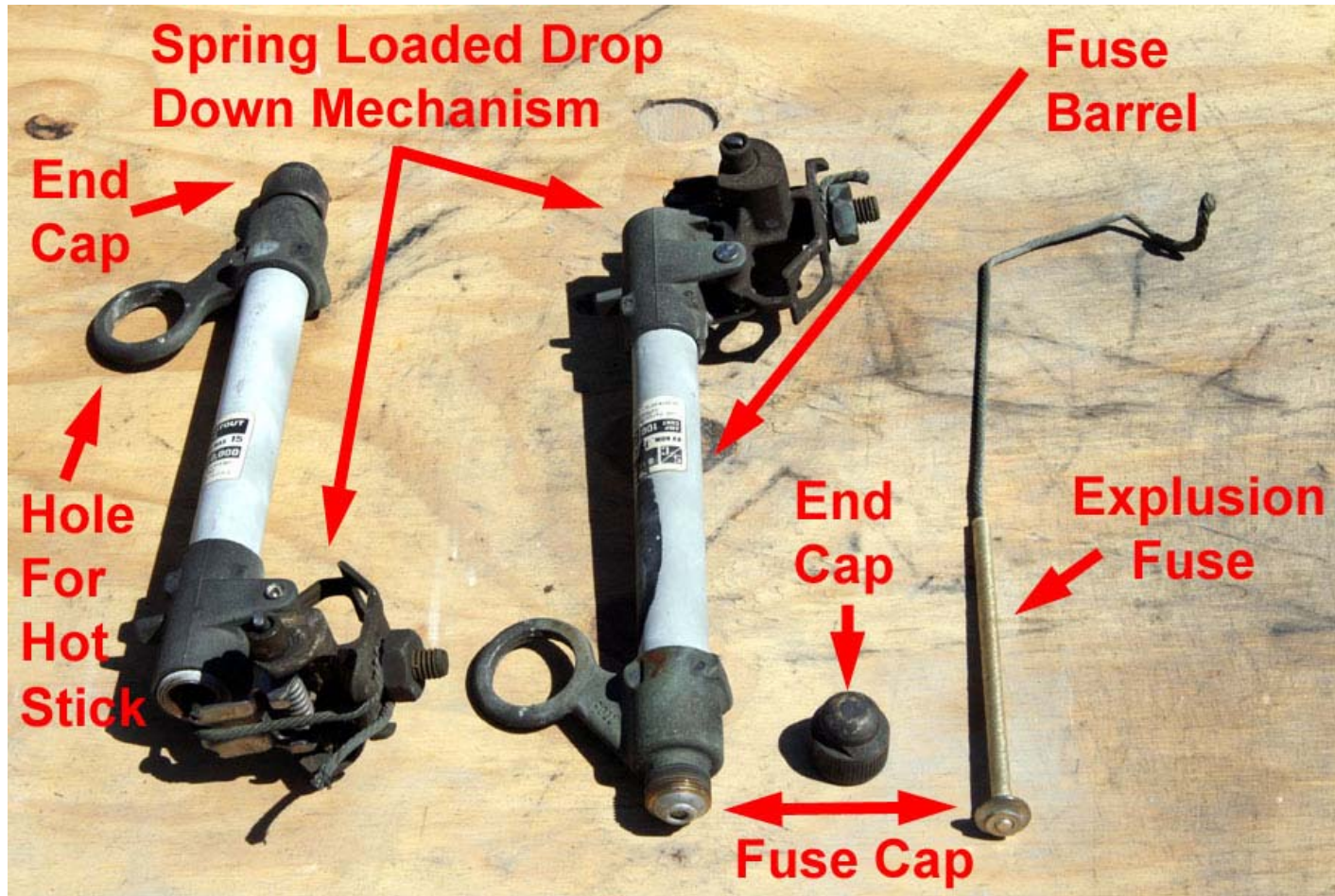

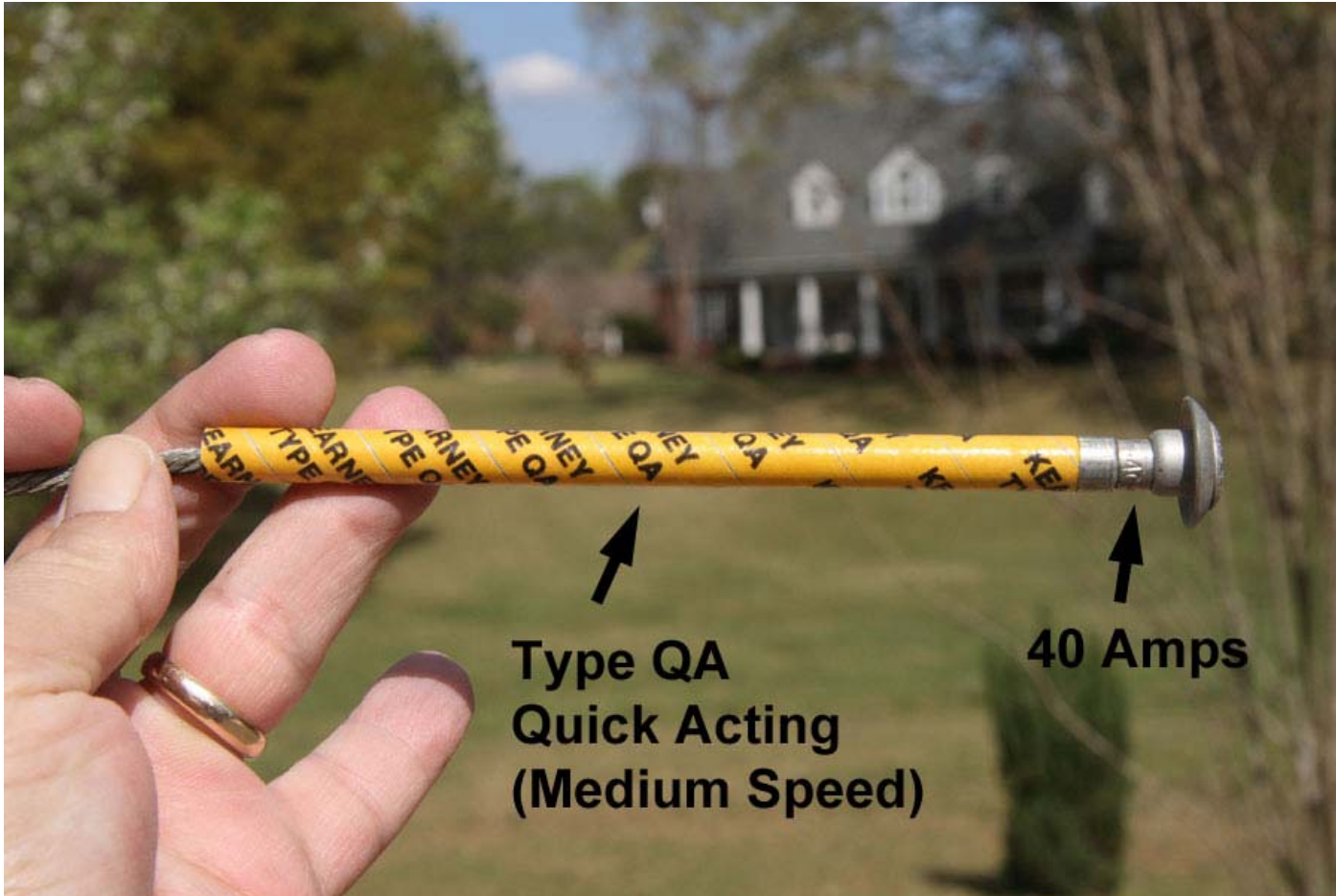

Type QA  
Quick Acting  
(Medium Speed)

40 Amps



- Meter Sockets are rated up to 320/400 amps.
- Above 400 amps, current transformers are used to measure the energy.



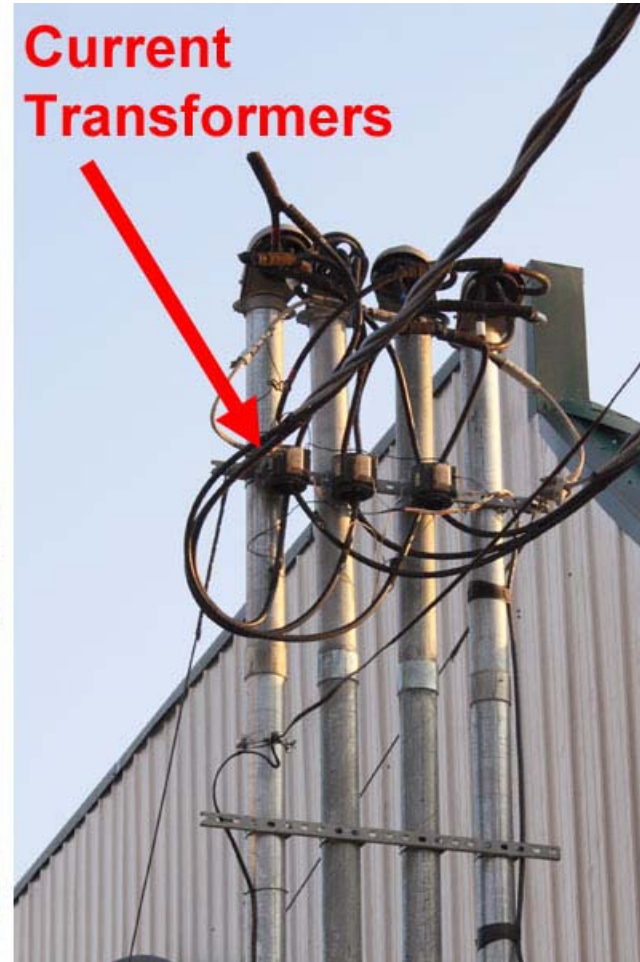

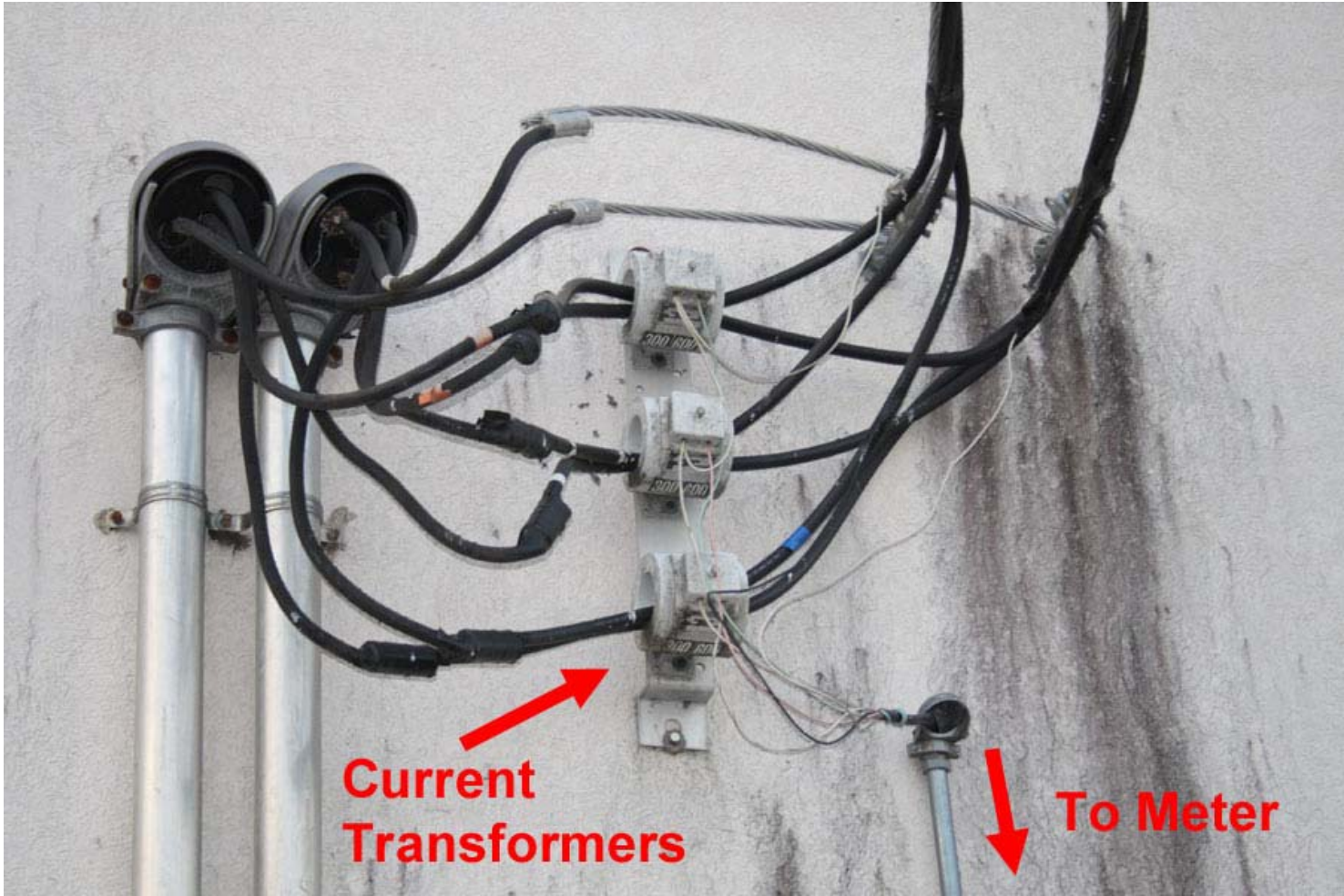

**Current  
Transformers**

**To Meter**





Test Question?

Pulling the electric meter at a commercial building will always disconnect power to the building?

True or False

Ans. False

# THREE-WIRE EDISON SYSTEM

## Single Phase

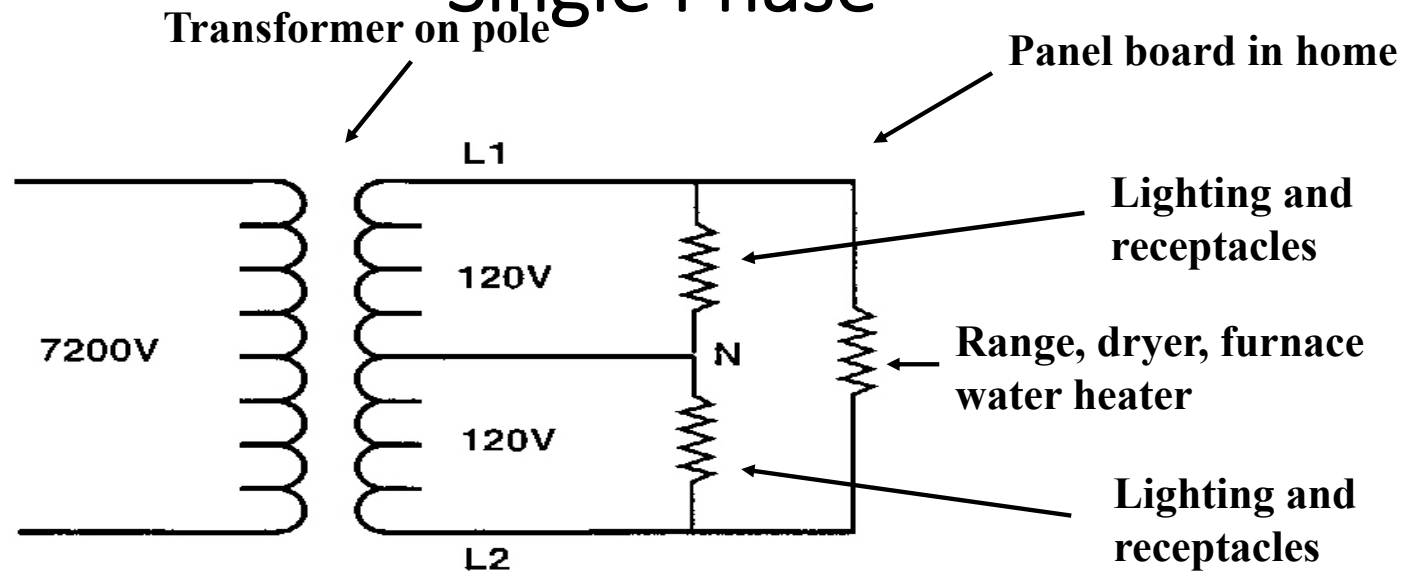

Lighting and receptacles are on 120 volt circuits. Because of the greater current requirements, dryers and furnaces are on 240 volt circuits.

**Notice:** No ground (earth) connection is shown. Ground is not required for operation. Ground is for lightning and fault protection. The neutral wire maintains 120 volts between the two 120 volt legs.

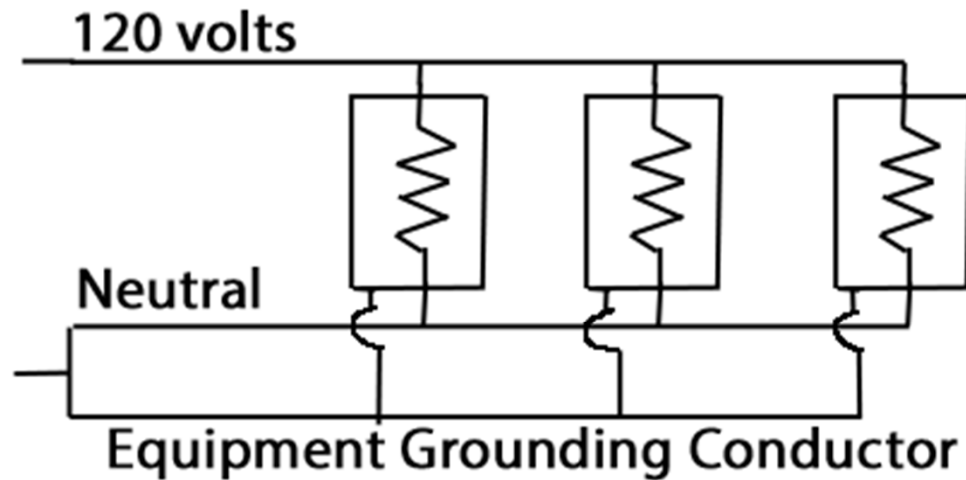

The equipment grounding conductor (EGC) was added in to NEC in the 1960's. The difference in the EGC and the neutral is that the neutral carries the return current of the circuit and no current flows in the EGC unless there is an electrical fault.

The NEC used "Grounded" conductor instead of neutral and "Grounding" conductor instead of equipment grounding conductor.

Skip

## DIGITAL METER

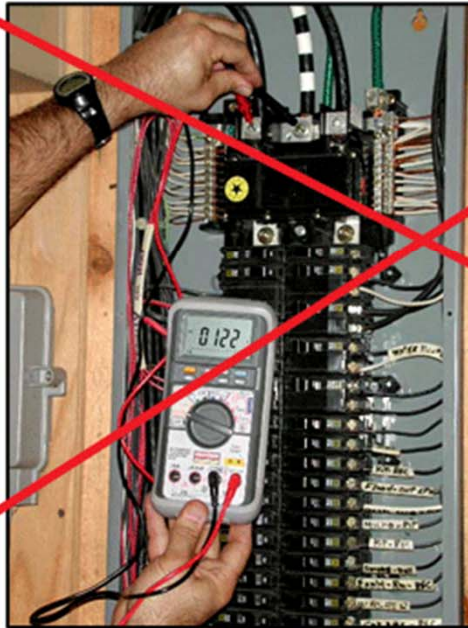

- Checking the Main service entrance conductors.
- One lead on the “hot” conductor the other to the Neutral Conductor
- 120 Volts





OK





## Fluke 2AC Alert Voltage Tester

[Visit the Fluke Store](#)

4.6 ★★★★★ 1,953 ratings | 27 answered questions

1K+ bought in past month



-10% \$37.77

List Price: \$41.99 ⓘ

FREE Returns ▾

Get \$60 off instantly: Pay \$0.00 \$37.77 upon approval for the Amazon Store Card. No annual f

Available at a lower price from [other sellers](#) that may not offer free Prime shipping.

<b>Brand</b>	Fluke
<b>Power Source</b>	Battery Powered
<b>Style</b>	Tester
<b>Item Weight</b>	0.1 Kilograms
<b>Item Dimensions LxWxH</b>	10.25 x 3 x 1.2 inches

### About this item

- Voltbeat technology and continuous self test so you always know it is working
- Upon detection, tip glows and beeper sounds
- Non-contact voltage detection from 90 to 1000 V ac
- Battery Check' ensures battery is in good condition
- Suitable for a wide range of residential, commercial and industrial needs

Roll over image to zoom in



You're shopping  
Vicksburg  
OPEN until 9 pm

Delivering to  
39180

voltage detector



My Account



Lists



Cart | 0 items

Store Finder Truck & Tool Rental For the Pro Gift Cards Credit Services Track Order Help

All Departments Home Decor, Furniture & Kitchenware DIY Projects & Ideas Project Calculators Installation & Services Specials & Offers Local Ad & Catalog

... / Electrical / Electrical Tools / Electrical Testers / Voltage Tester

Internet # 317460355 Model # NCVT1PR Store SKU # 10065

Best Seller

Klein Tools

### Non Contact Voltage Tester Pen, 50-1000V AC

★★★★★ (2076) Questions & Answers (22)



Hover Image to Zoom

\$19<sup>97</sup>

- Non-contact voltage tester detects voltage 50 to 1000V AC
- Volt pen has red LED lights and audible tones to indicate voltage
- Not recommended for tamper-resistant outlets
- [View More Details](#)

#### Vicksburg Store

✓ 5 in stock Aisle 06, Bay 018

Pickup at Vicksburg

Delivering to 39180

#### Pickup

Today  
5 in stock  
FREE

#### Delivery

Friday, Oct 27  
192 available  
FREE

Get it as soon as today. Schedule your delivery in checkout.

#### Protect This Item

Select a Home Depot Protection Plan by Allstate for:

- 2 Year / \$3.00
- No thanks

[What to Expect](#)

# Thermostats

## Bimetal Strip

Two Metals Bonded Together with Different Coefficients of Expansion

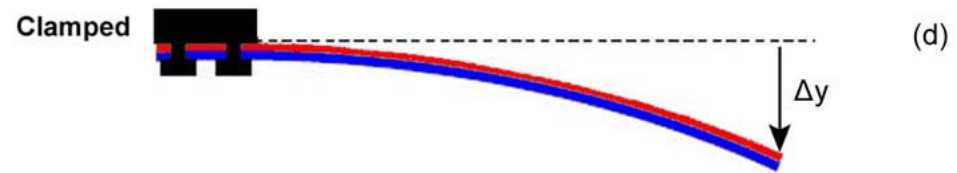
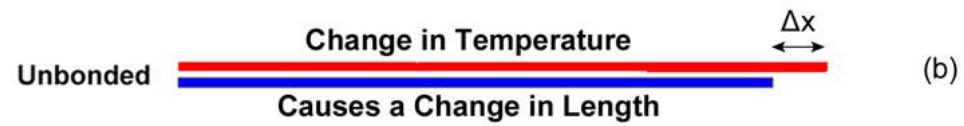
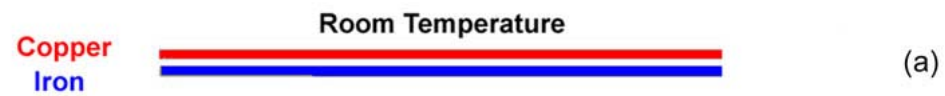

# Thermostats

- Bimetal Thermostats are found in:
  - A) Circuit Breakers
  - B) Cooktops and Ranges
  - C) Clothes Dryers
  - D) Furnaces
  - E) Coffeemakers
  - F) Toasters
  - G) Clothing Irons
  - H) Motors
  - I) All of the Above

Ans.: I – All of the Above.

# SERVICE EQUIPMENT TERMINOLOGY

**Most likely place for an open neutral to occur from trees and connectors.**

**Note: No overcurrent protection is provided between the transformer and the home. The utility only provides protection on the primary side of the transformer. This protection is for the transformer only. Not the home.**

**Underground utility feeds are called service laterals.**

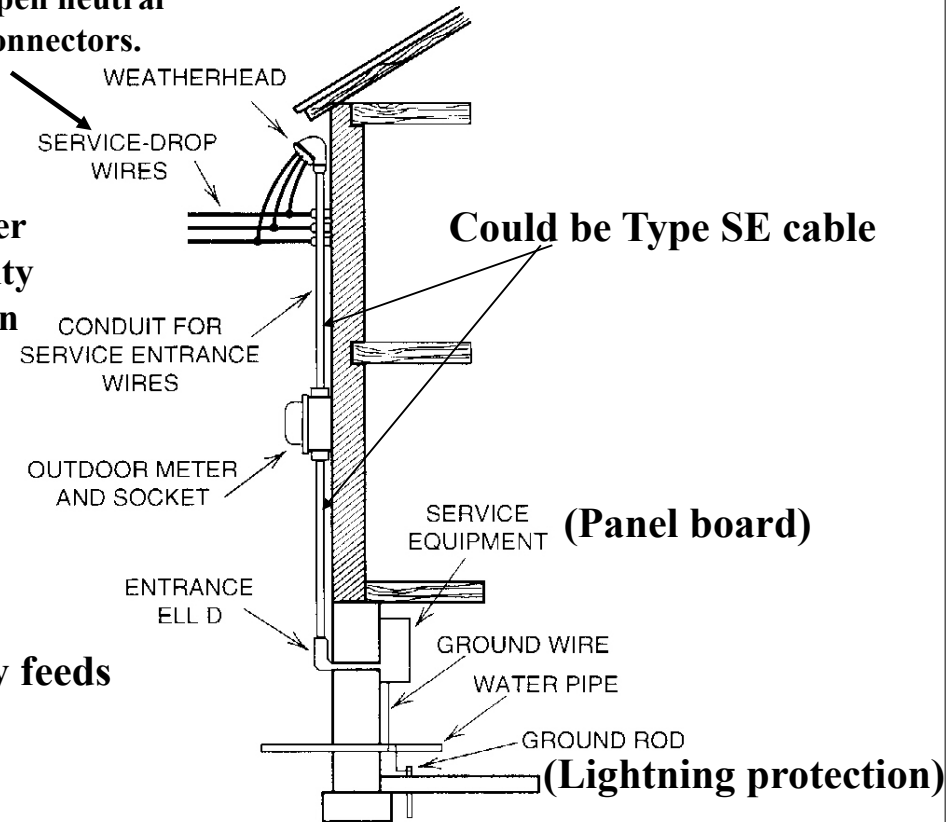

# METER BASE





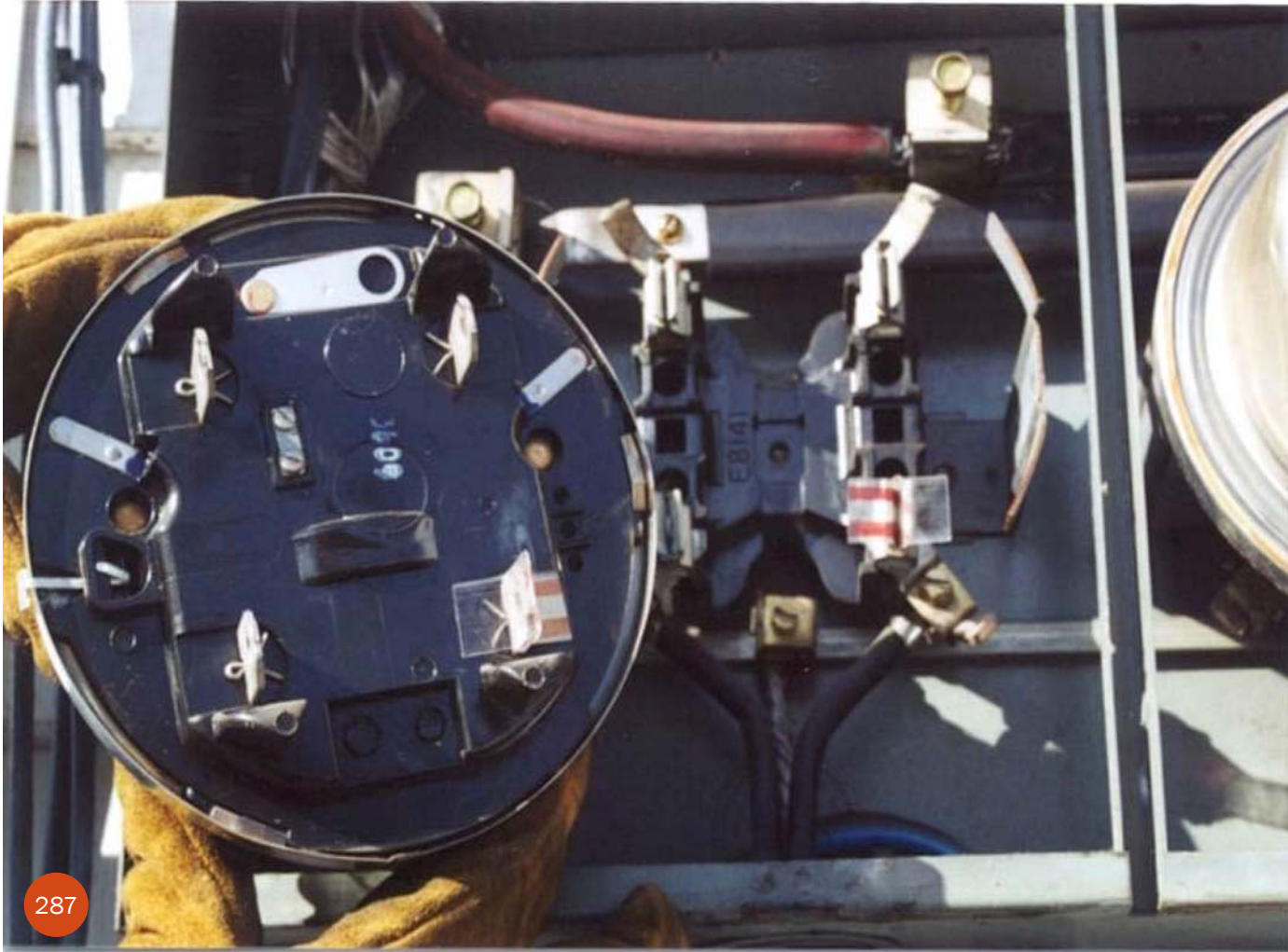





# Circuit Breakers

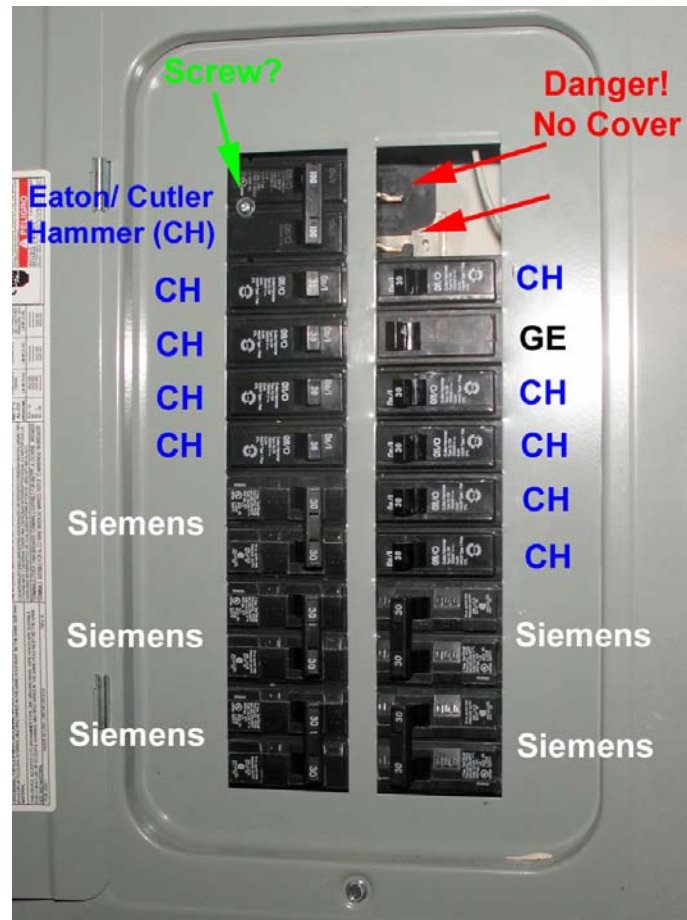

# ARC FAULT DAMAGE-FLAME IMPINGEMENT

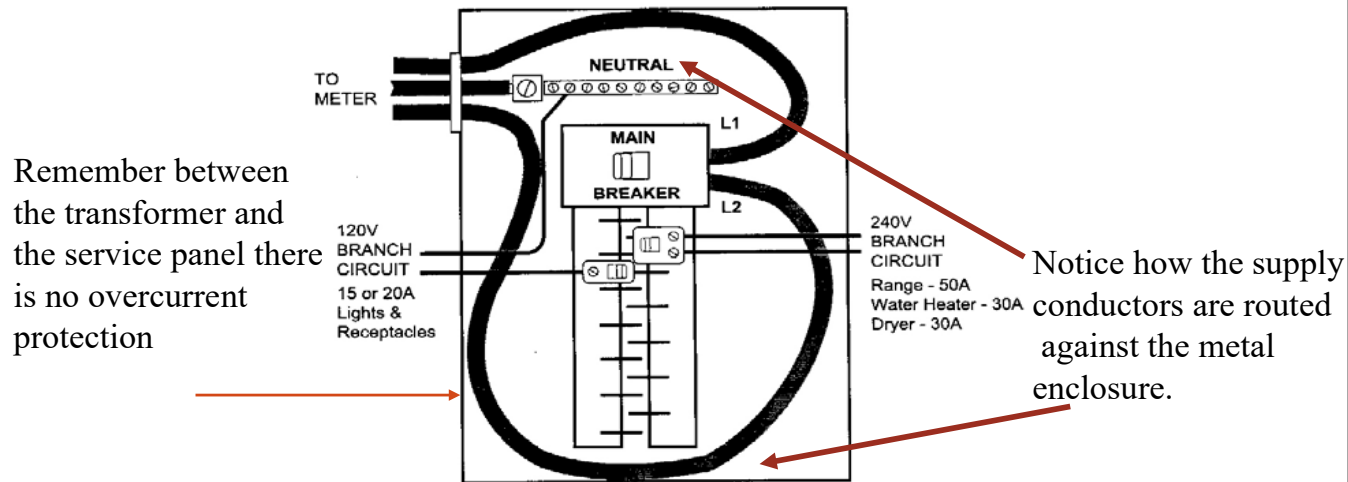

As the fire attacks the panel the metal begins to heat up. The insulation between the metal enclosure and the supply conductors melts. This allows the conductor to arc to the enclosure. Since there is no overcurrent device the arcing can occur in multiple locations and for long periods. The result is long, snaky arc burn holes in the enclosure adjacent to the conductors. The conductors exhibit arcing and melting. This type of damage is commonly mistaken for fire causation, but, is almost always the result of an external attack by fire.



# CIRCUIT BREAKERS

Typical residential and commercial style circuit breakers operate on two trip mechanisms:

- **Thermal** (*overloads*)
- and
- **Magnetic** (*short circuits*)

Circuit breakers are at “rest” in the **OFF** position, and are held in the **ON** position by a latching mechanism that is spring-loaded.

- When a circuit breaker trips, it releases a cocked spring mechanism that separates the electrical contacts. Circuit breakers have two means of tripping:
- (1) An electromagnet that trips almost instantaneously when the current is between nine (9) and 15 times the rated current of the circuit breakers (USA),

And

- (2) A temperature sensitive bimetal strip that bends and releases the spring mechanism at a calibrated temperature. Usually, the temperature of the bimetal strip is proportional to the amount of current passing through the circuit breaker. However, the bimetal strip will react and bend to any rise in temperature. The rise in temperature may be due to a loose wire connection, misalignment of the circuit breaker contacts, or the heat from a fire.



550 °F

I/ON

20

O/OFF

10 kA  
120/240V~

450 °F

I/ON

20

O/OFF

10 kA  
120/240V~

10 26 '05

- Circuit breakers are sized to protect the integrity of the wire insulation; they are not sized to protect human life.
- If a circuit breaker is overloaded to a value of 135% its rated current, it must trip within one hour.
- If a circuit breaker is overloaded to a value of 200% its rated current, it must trip within two minutes.



# Circuit Breakers & Wire Sizes

Circuit Breaker	American Wire Gage (AWG)	Color After 1999	Appliance
15	14	White	Lights
20	12	Yellow	Receptacles
30	10	Orange	Water Heater & Dryer
40	8		Range & Furnace
50	6		Range & Furnace

10 AWG wire is 0.1 inch in diameter and has a resistance of 1 ohm per 1,000 feet. As the AWG size get larger the diameter gets smaller.

- All circuit breakers do not trip to the center position. The following circuit breakers do not have a center position, and they trip to the "off" position: Cutler Hammer, Bryant and Murray.

# GFCI CIRCUIT BREAKERS



# GFCI CIRCUIT BREAKERS

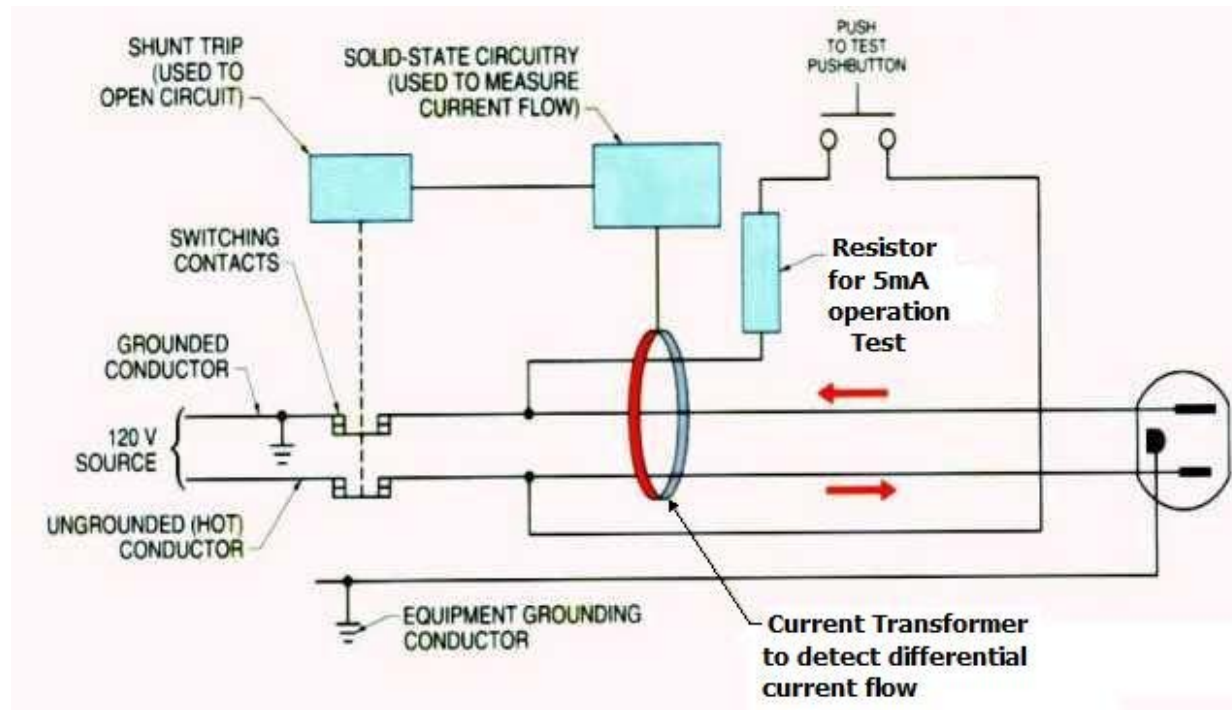

If current returning is not equal to current entering the circuit, that means it's finding another path to take!

# ARC-FAULT CIRCUIT-INTERRUPTERS

- AFCI: a device intended to provide protection from the effects of arcing type faults
- Recognizes the electrical waveform characteristics that are unique to arcing
- Required for all 125-volt, single phase 15- and 20-ampere branch circuits supplying outlets installed in living and activity areas (NEC 2014)
- Also available in feed-through outlet



## ARC-FAULT CIRCUIT-INTERRUPTER BREAKERS

Listed “Combination” AFCI devices protect against two types of

**Series Arcing:** Arcing between ends the  
same conductor at a break

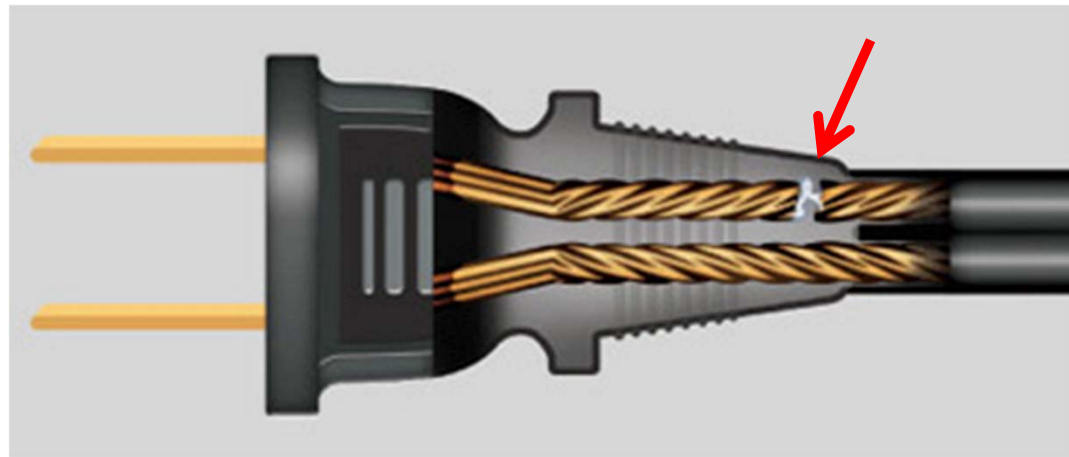

Usually self-current-limiting – once conductor is severed, current flow and arcing stops.



# ARC-FAULT CIRCUIT INTERRUPTER PROTECTION

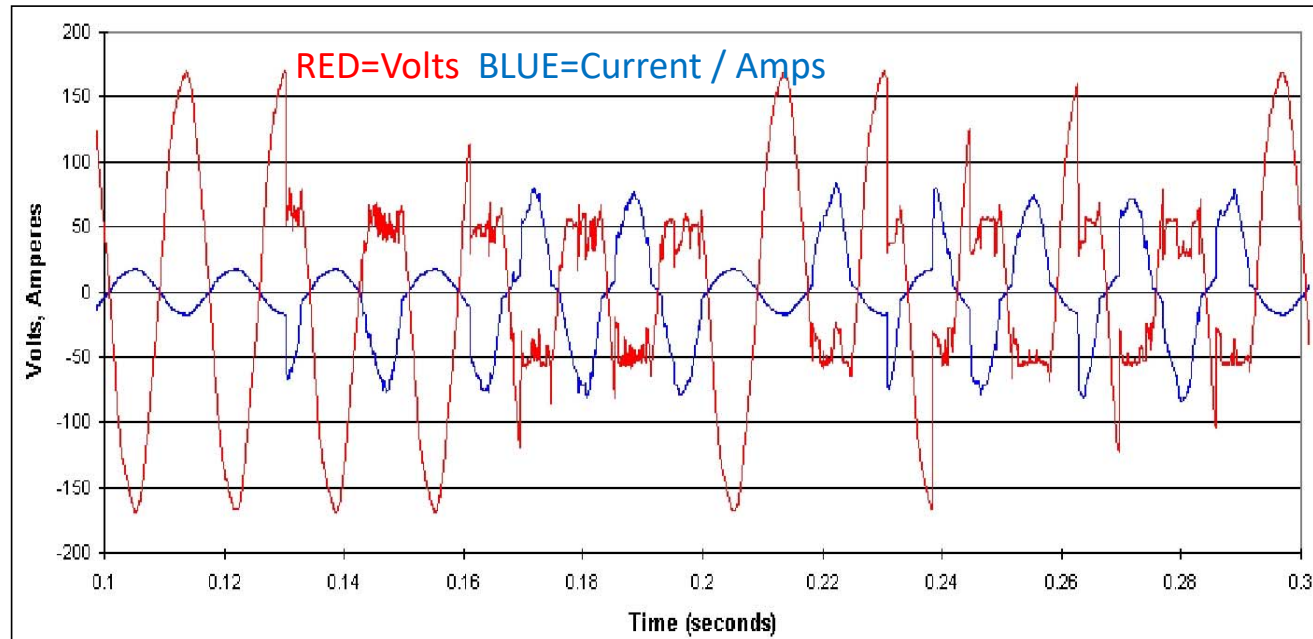

*Graph courtesy of 'The Arc-Fault Circuit Interrupter, An Emerging Product,' by George D. Gregory and Gary W. Scott, IEEE Transactions on Industry Applications, Vol. 34, No. 5, Sept/Oct. 1998, Publication 0093-9994/98*

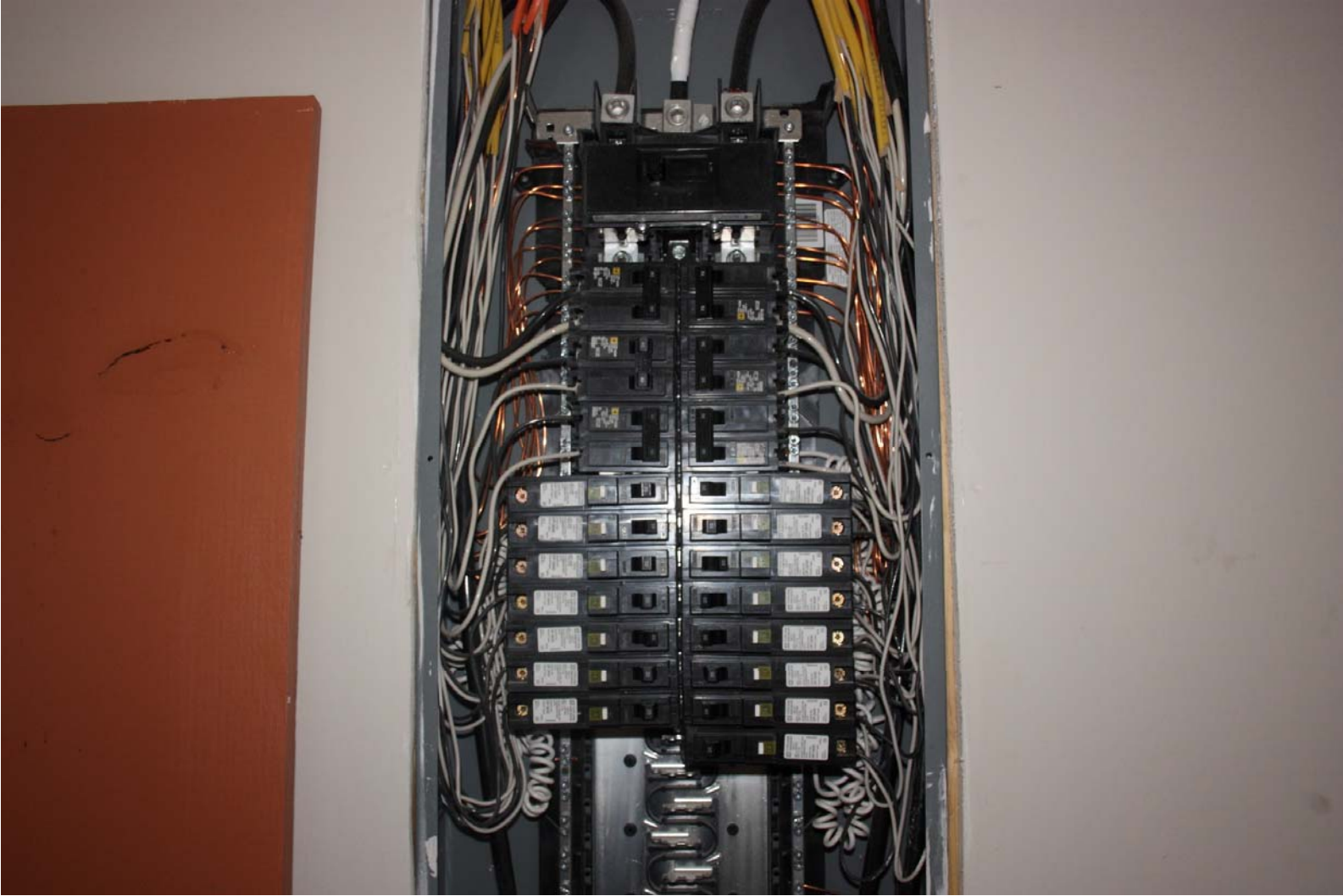

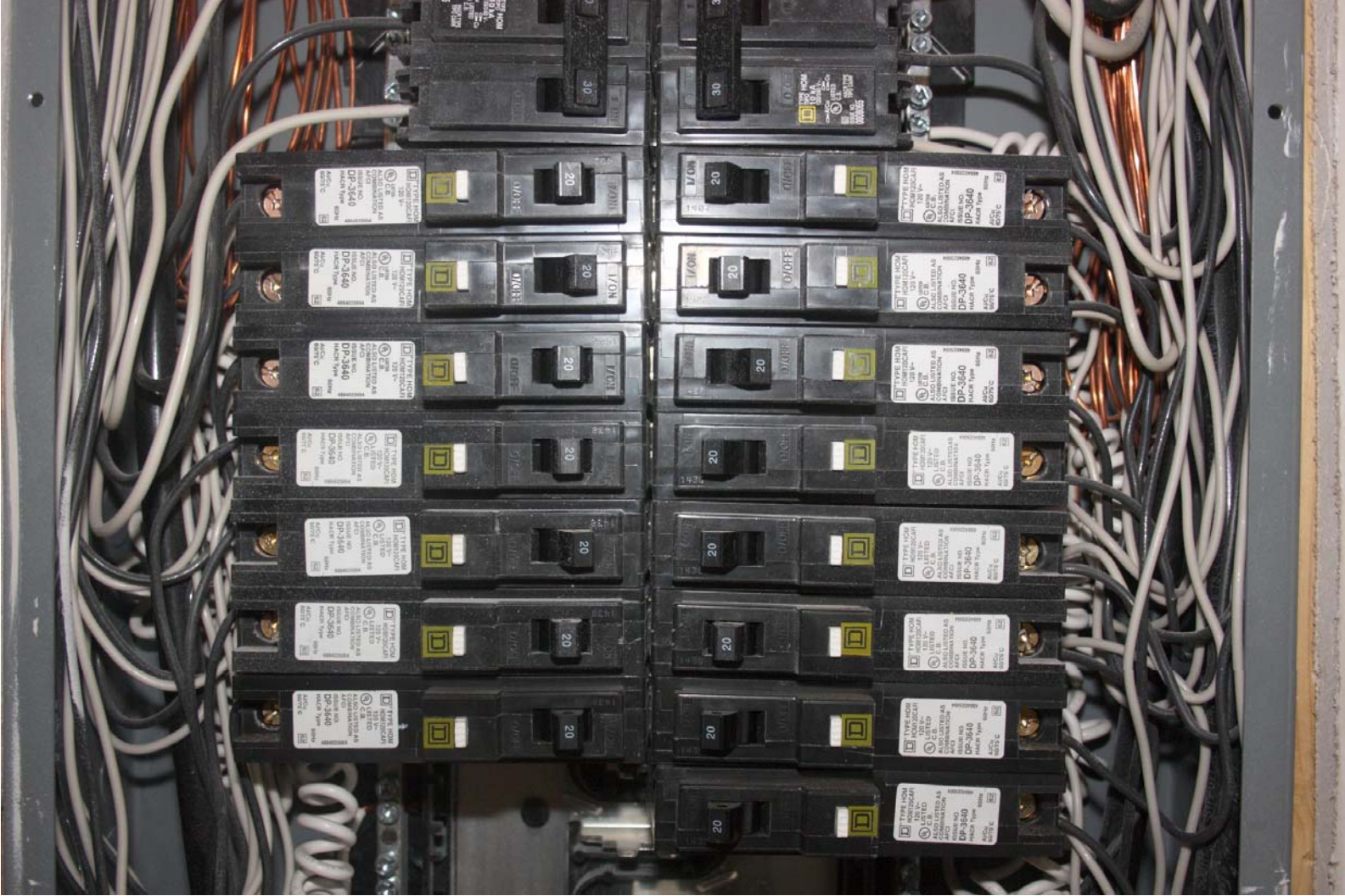



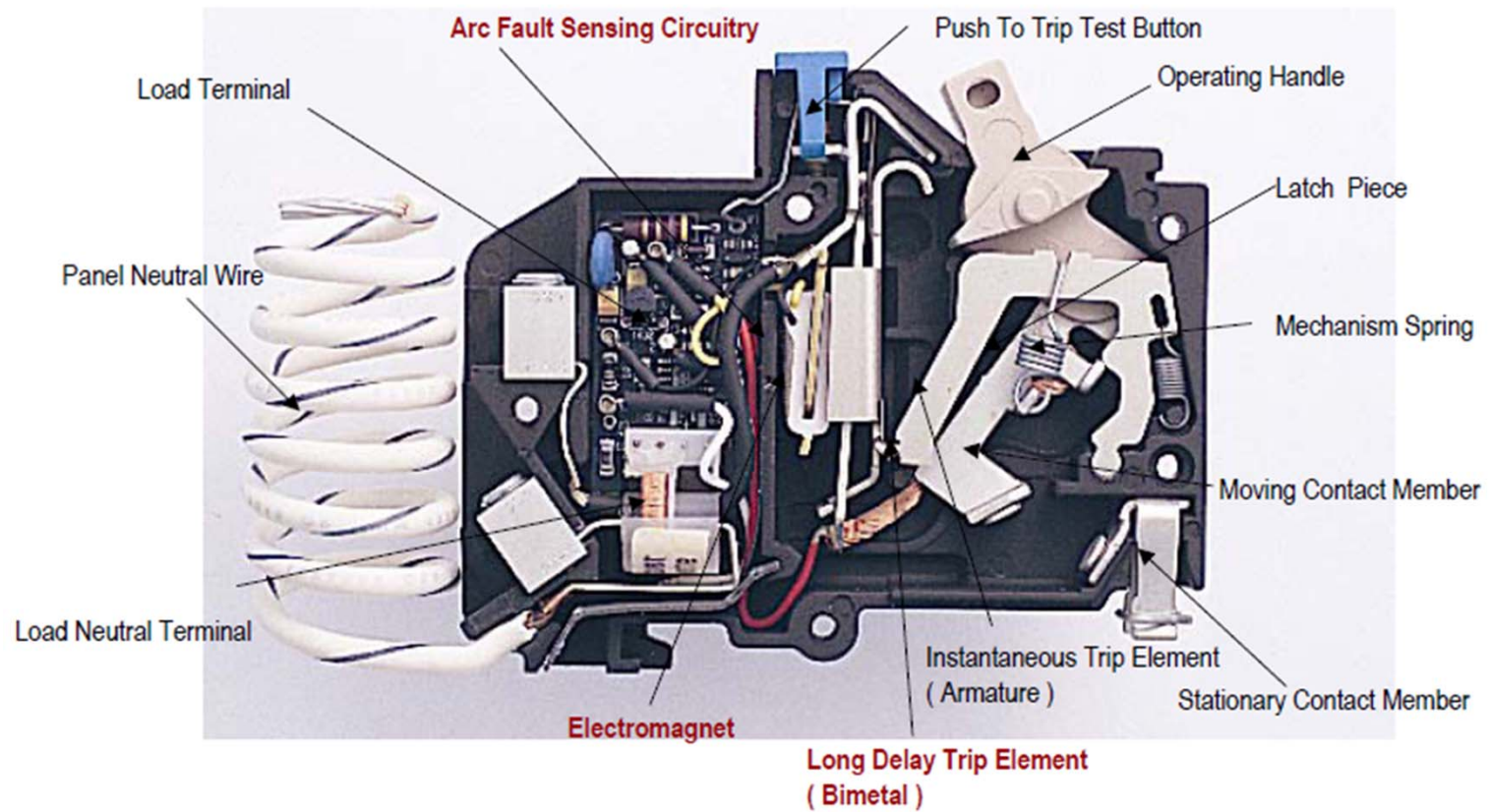

# CIRCUIT BREAKERS

## GTE/ SYLVANIA "ZINSCO" PANELS

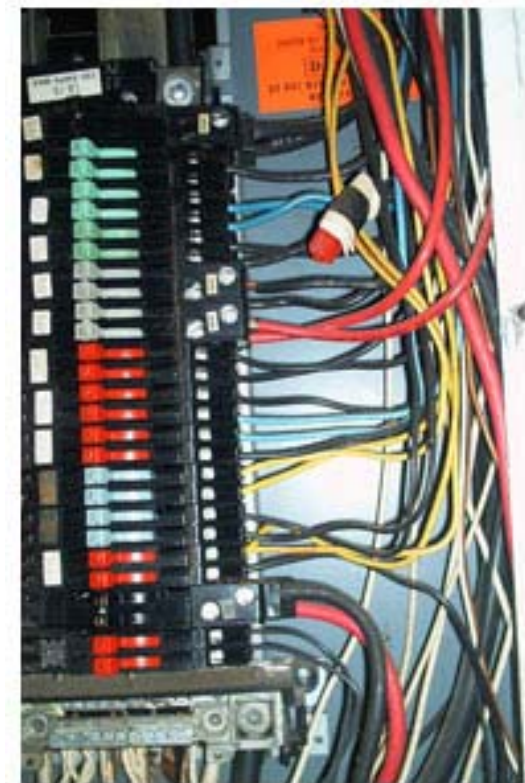
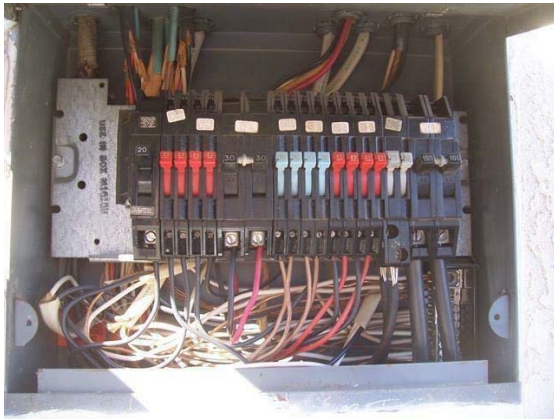

# Zinsco Circuit Breakers













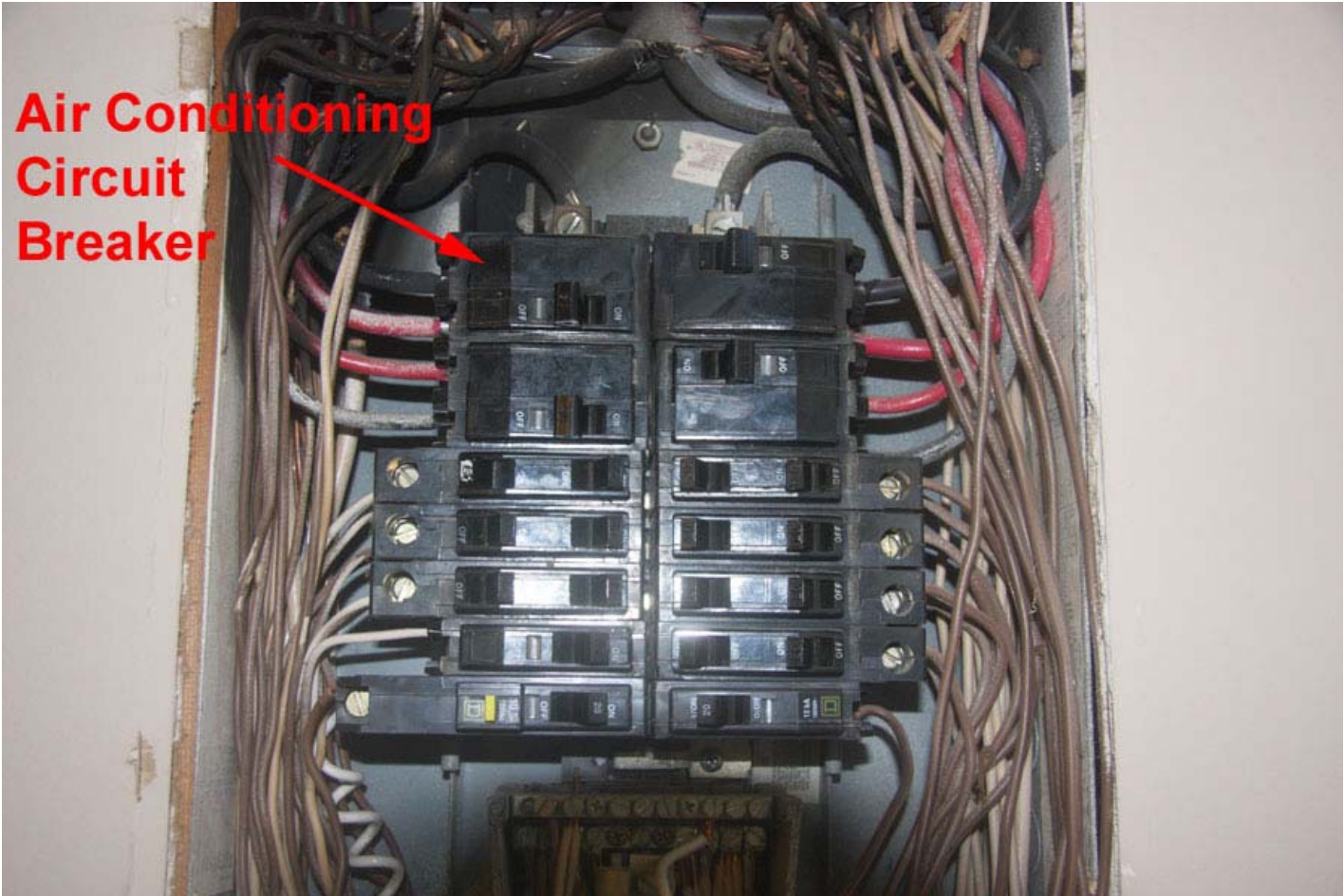

**Air Conditioning  
Circuit  
Breaker**

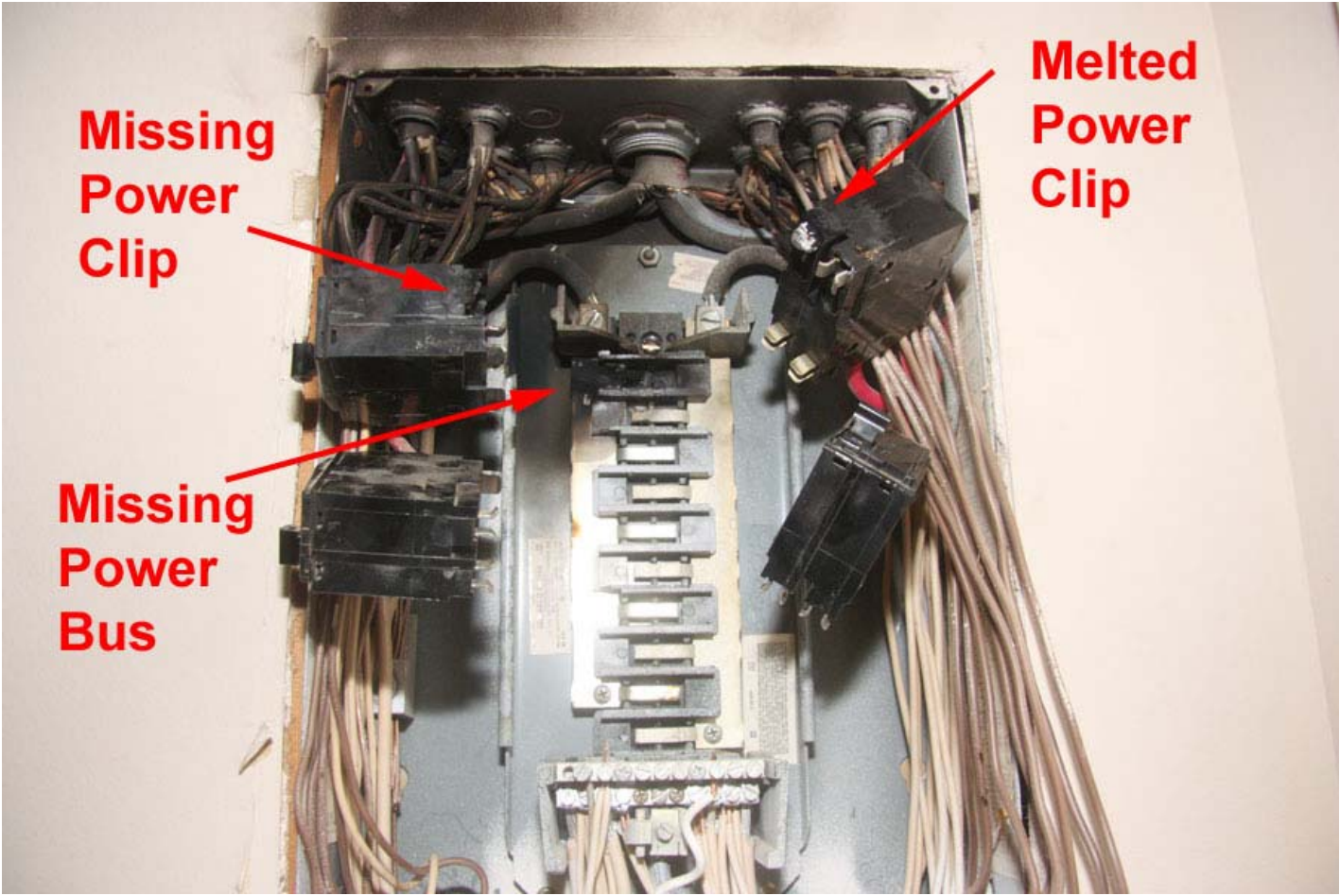

**Missing  
Power  
Clip**

**Missing  
Power  
Bus**

**Melted  
Power  
Clip**

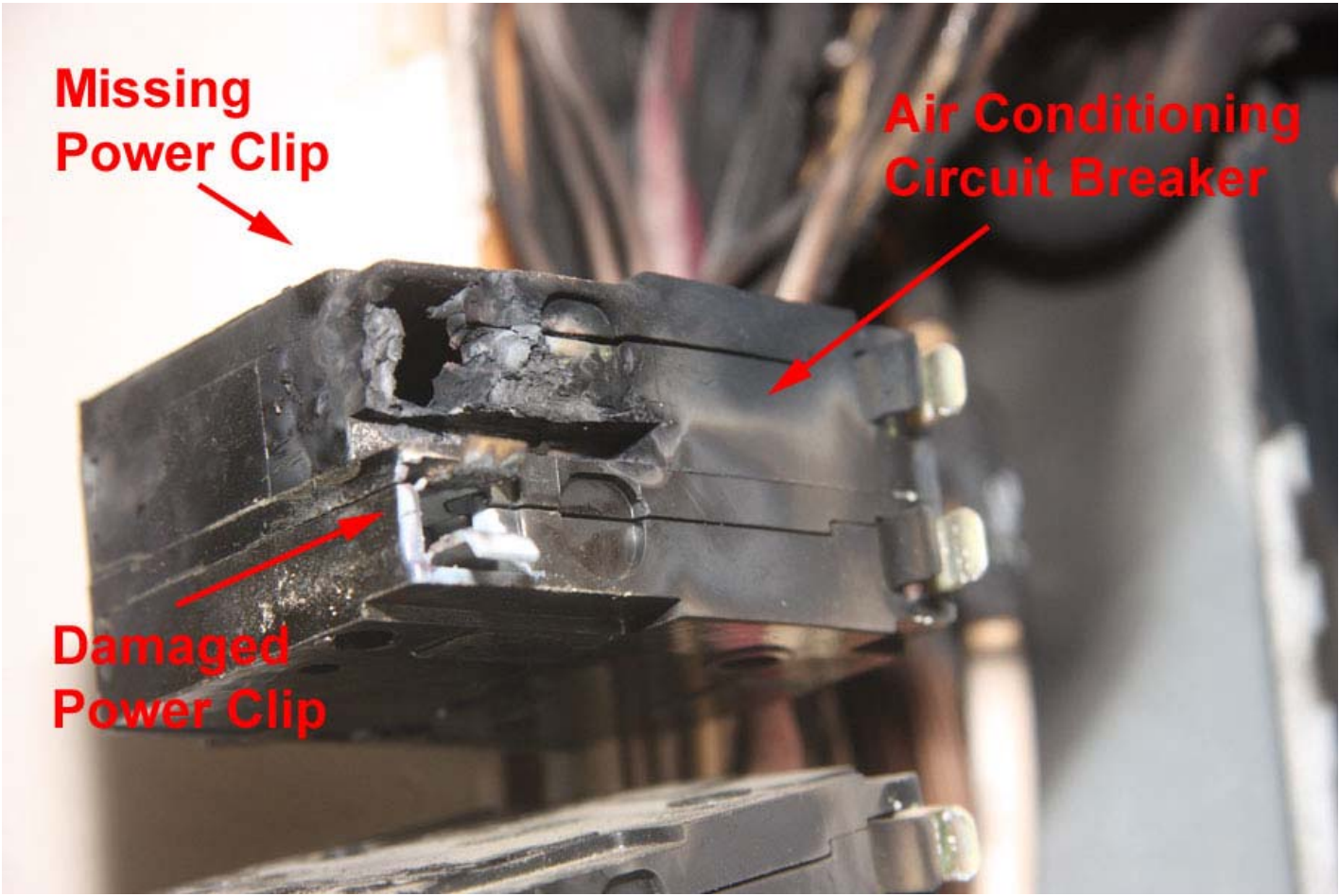

**Missing  
Power Clip**

**Air Conditioning  
Circuit Breaker**

**Damaged  
Power Clip**



**Oxidized Screw (Rust)  
Sign of Overheating**



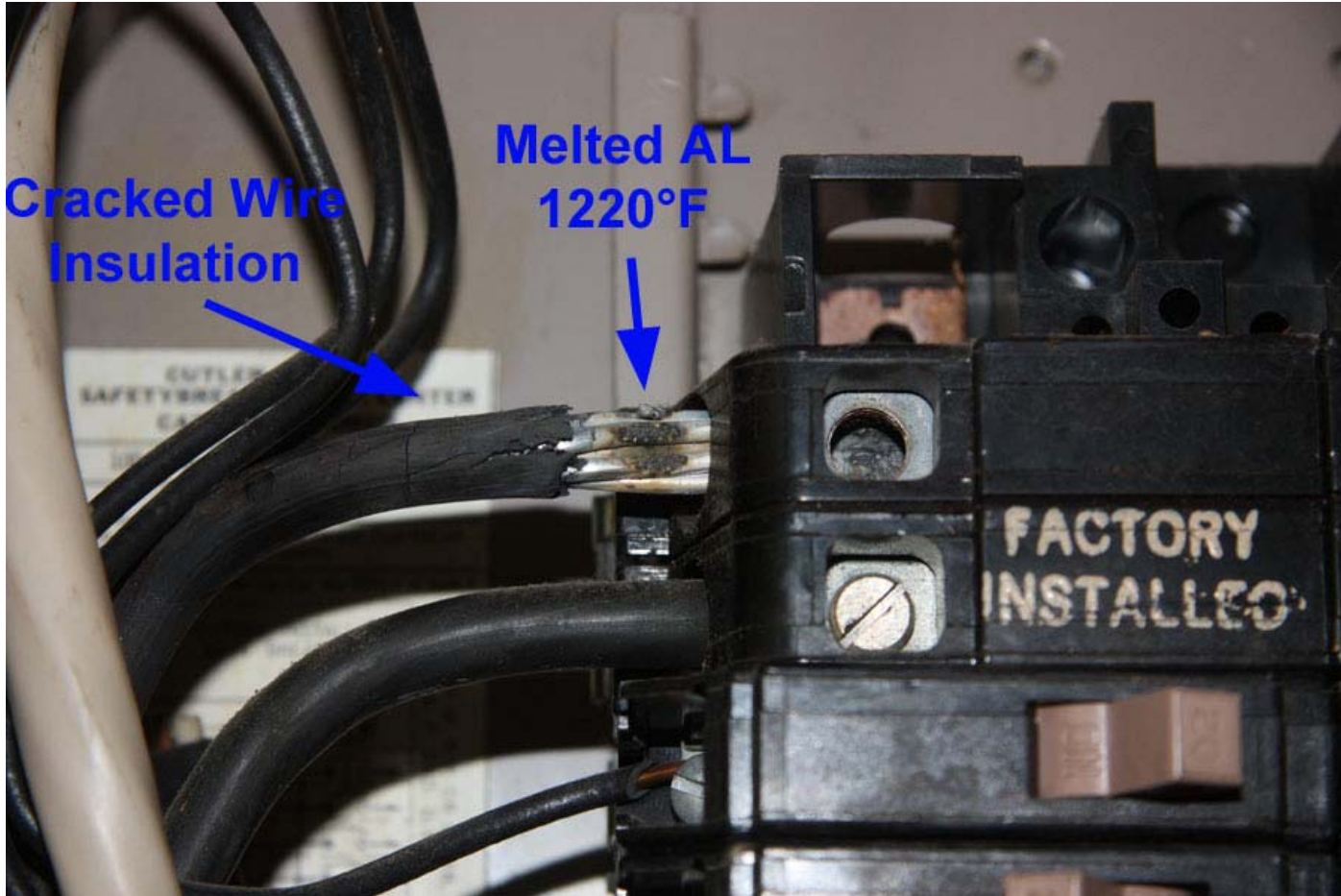

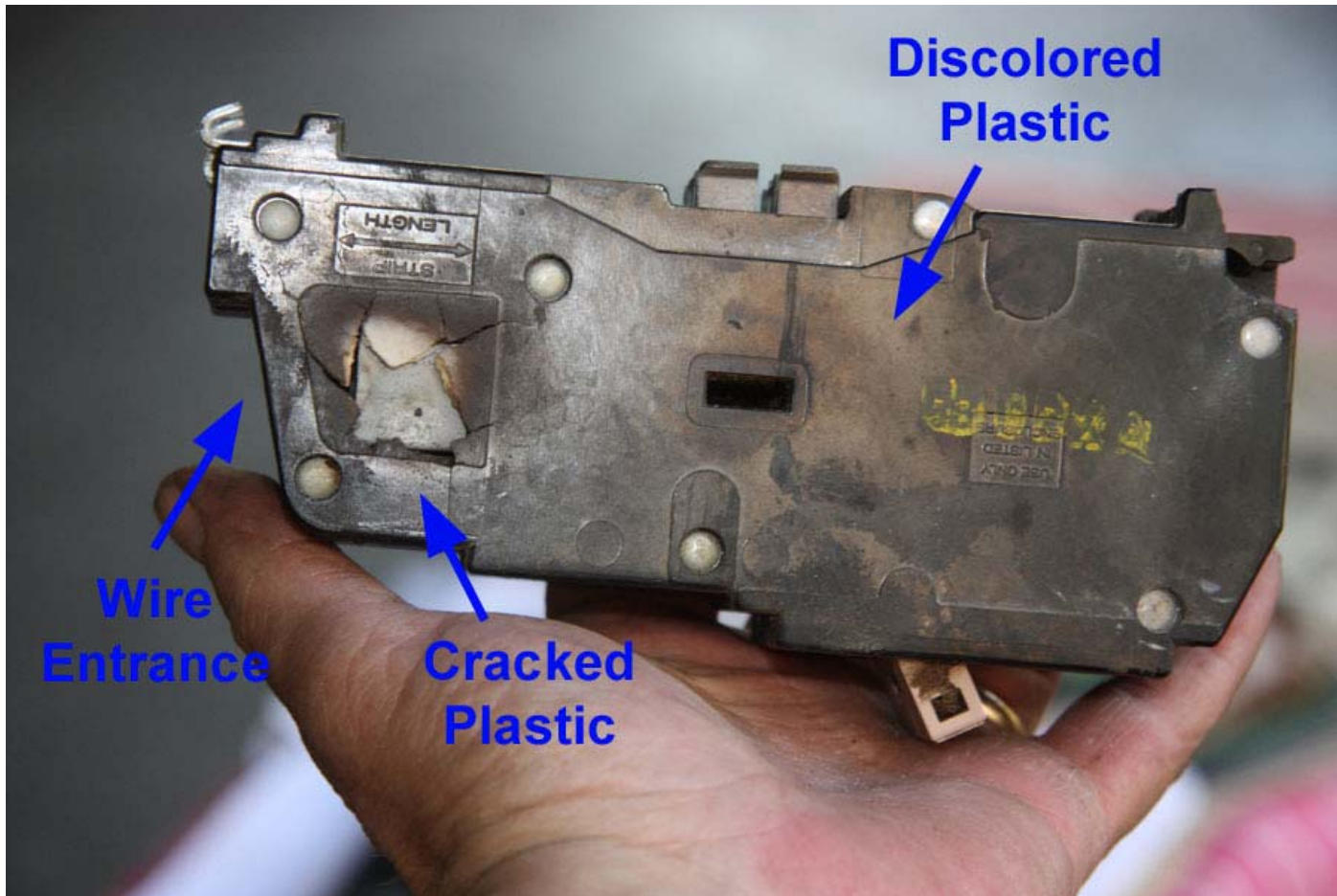

Discolored  
Plastic

Wire  
Entrance

Cracked  
Plastic





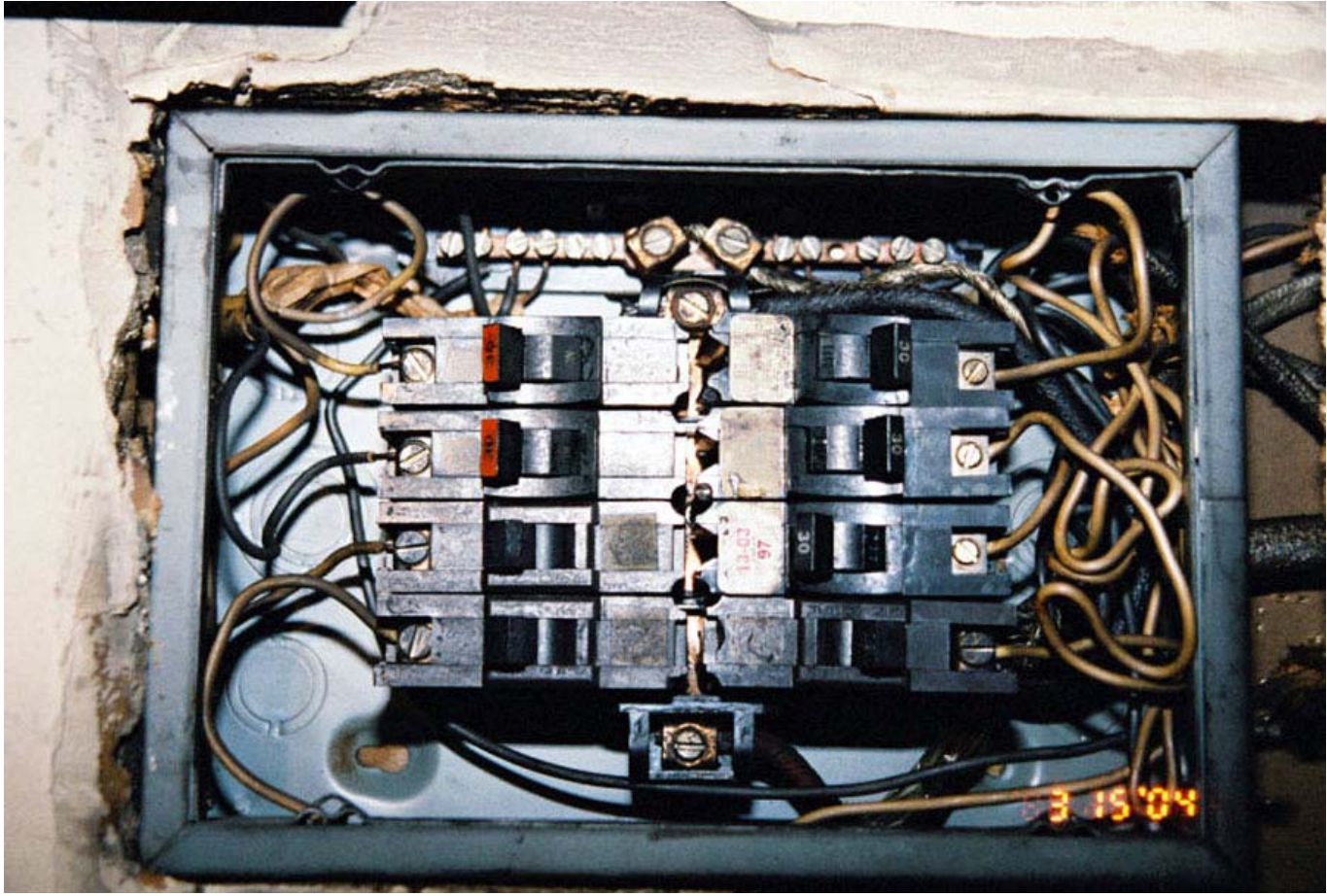



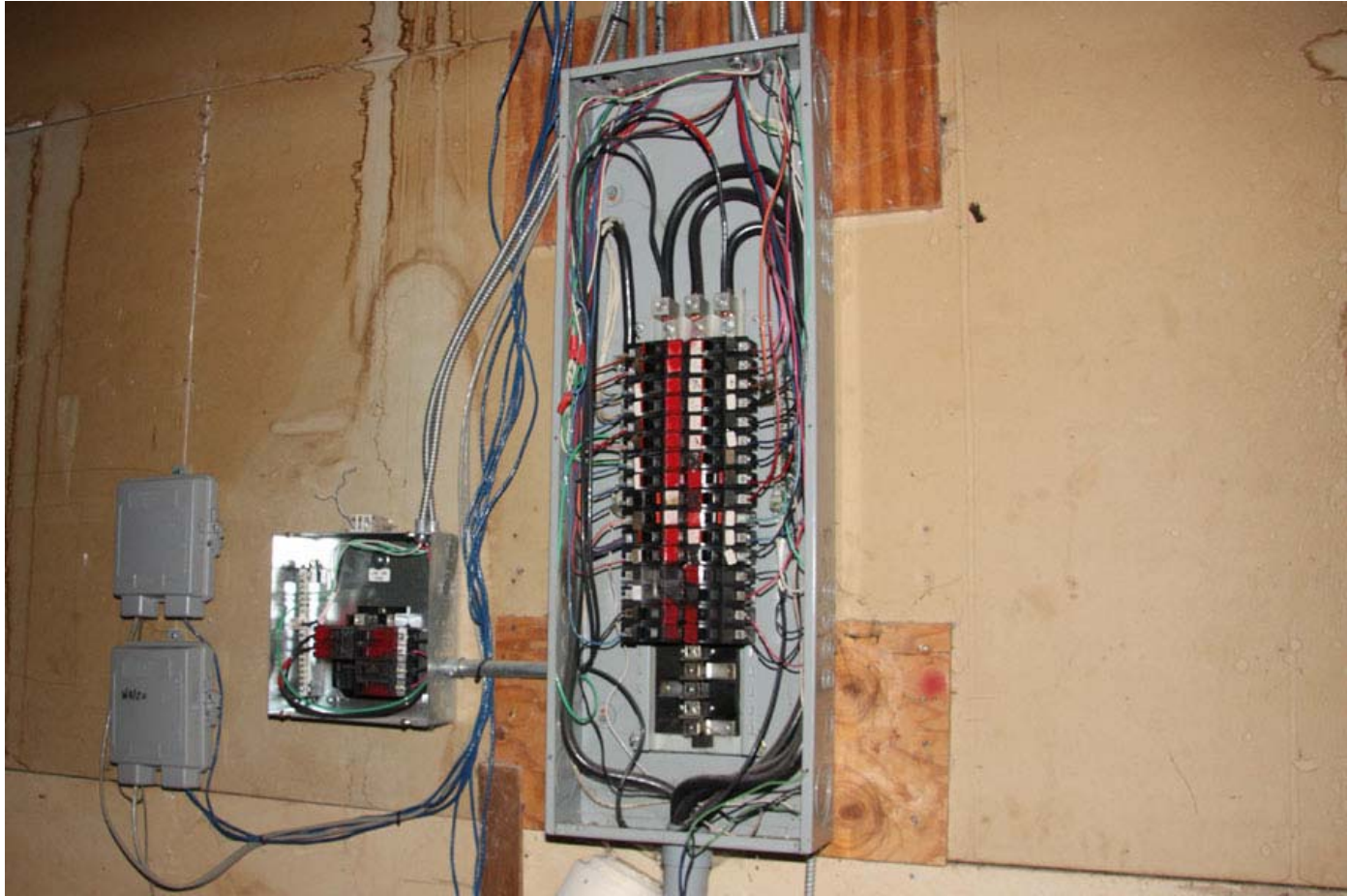





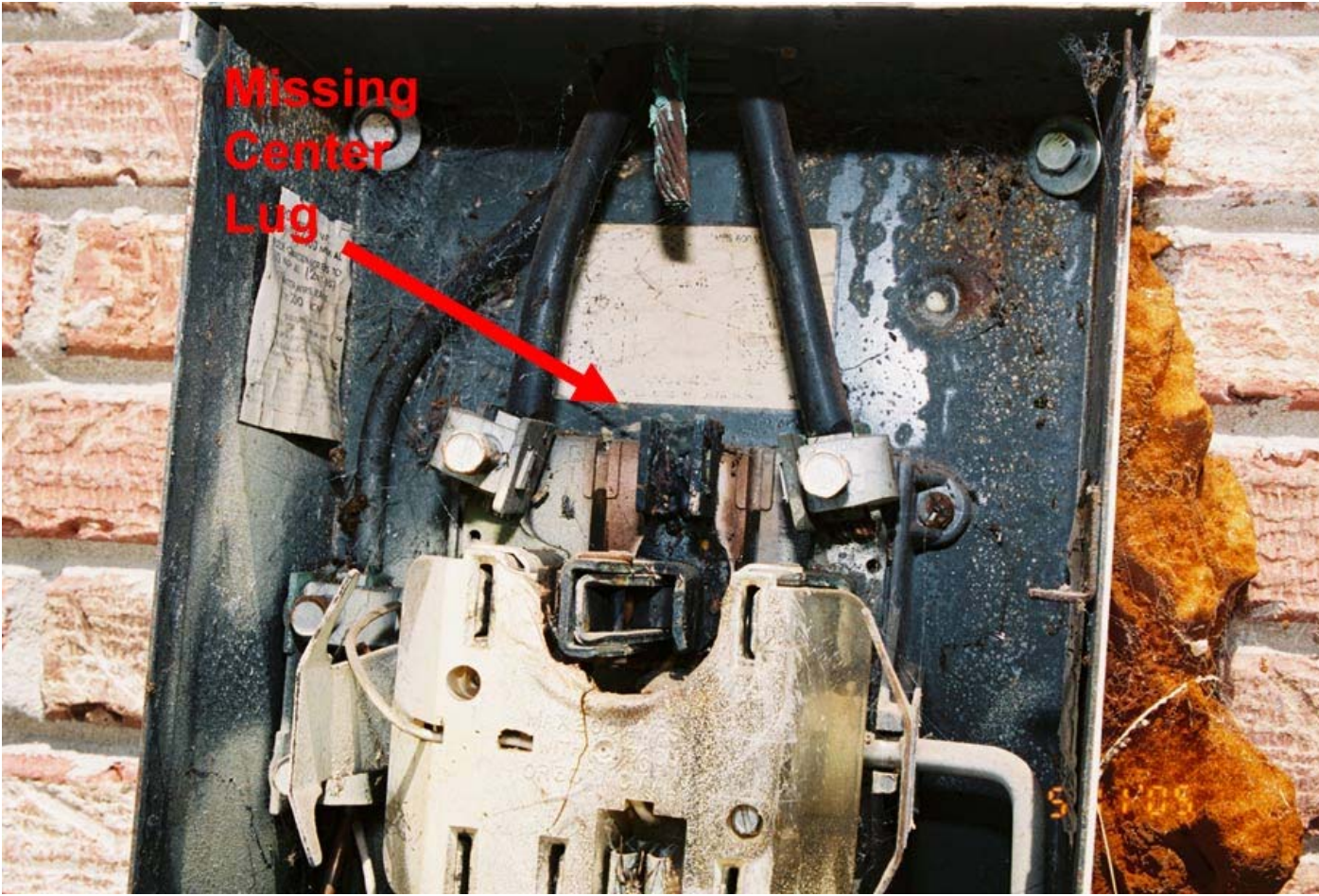

**Missing  
Center  
Lug**

# DOCUMENT THE PANELBOARD

- **Note the positions of circuit breakers (on, tripped, off)**
  - **Remember, some breakers trip to “off”**
- **Note what fuses are blown**
- **Copy any legend**
- **Find out which, if any, breakers were disturbed during or after the fire**
- **Determine if any breakers tripped often**
- **Find out if recent work has been performed**
- **Determine if breakers were regularly used as switches**
- **Remove cover and document interior**
- **Look for burned or melted insulation on wiring**
- **Verify panelboard/enclosure is properly grounded**
- **Check main connections**
- **Look for modifications or poor workmanship**
- **DO NOT MOVE BREAKER HANDLES!**



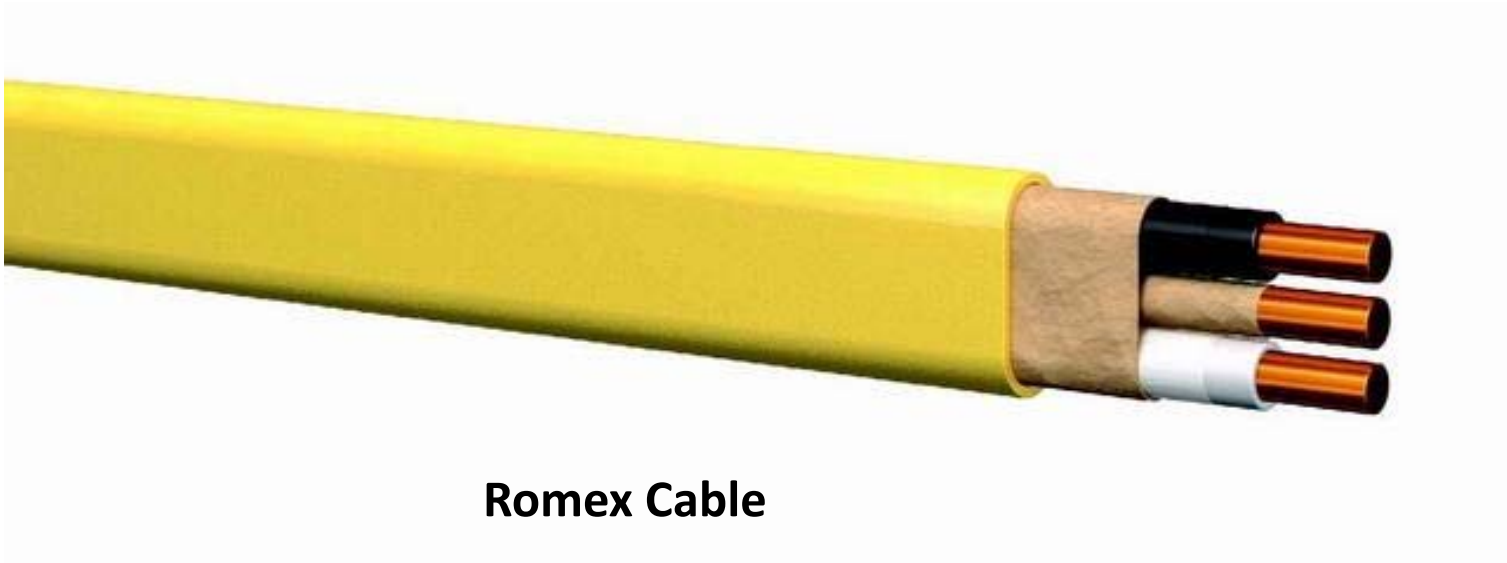

**Romex Cable**

F08-049 – In Attic, Cable to Furnace.



F08-049: Localized Melting at the Grounding Conductor





F08-049: Cable Burned from the Inside out.  
Hot and Neutral Wire Insulation Undamaged

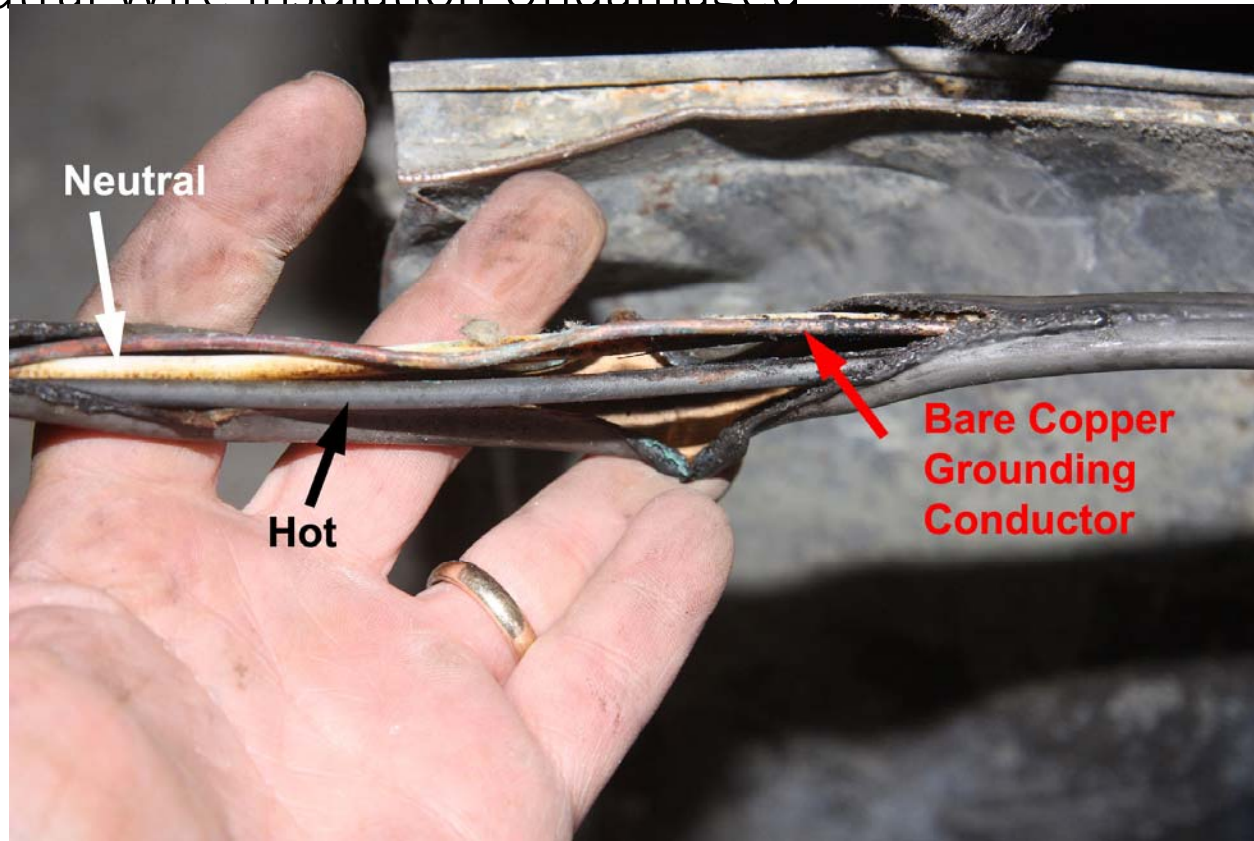

- What caused this damage?
- Answer – The neutral on the outside of the house became energized. This can occur on either side of the transformer. That is, the 8,000 volt line or one of 120 volt lines came in contact with the outside neutral, which is usually a bare conductor.
- Current flows into the house through the neutral without passing through a circuit breaker, and finds a path to earth ground. Usually the path is a water or gas line.

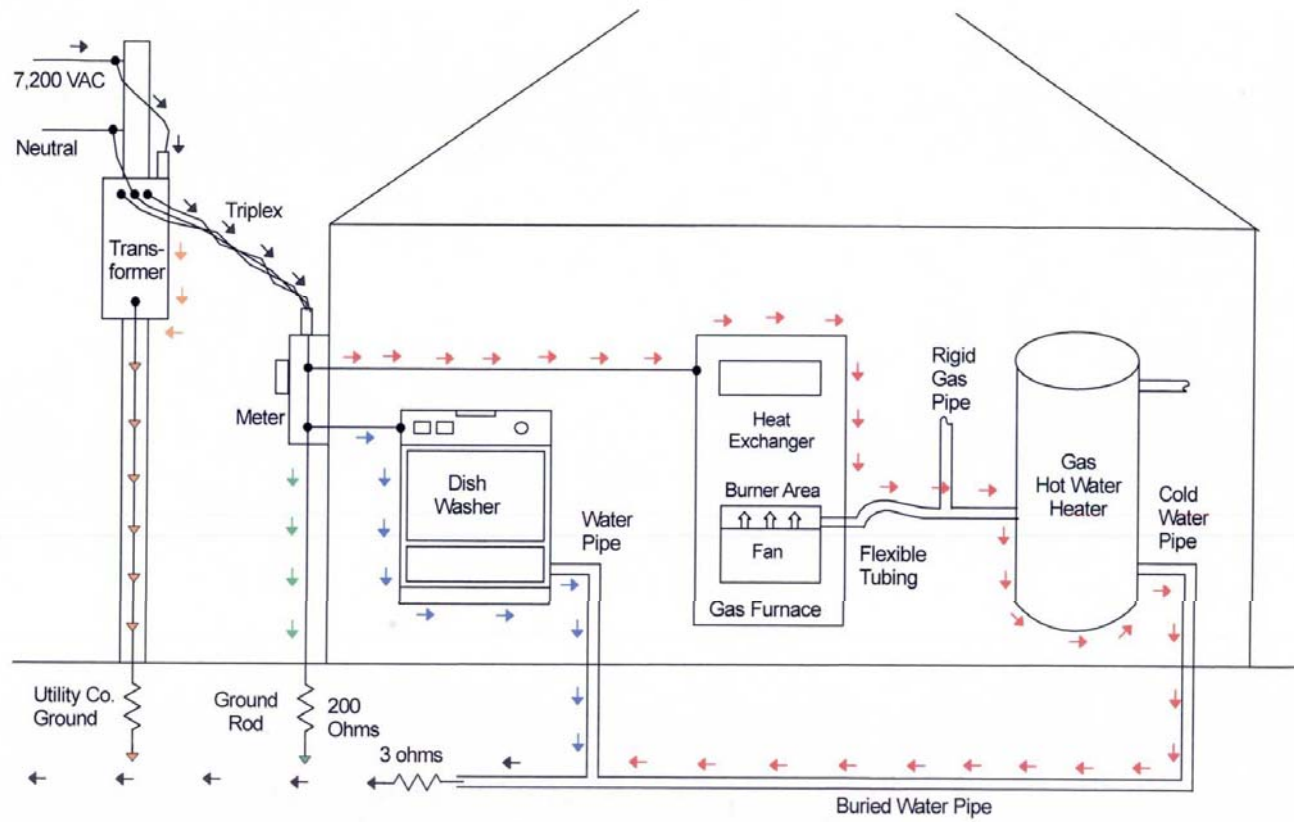
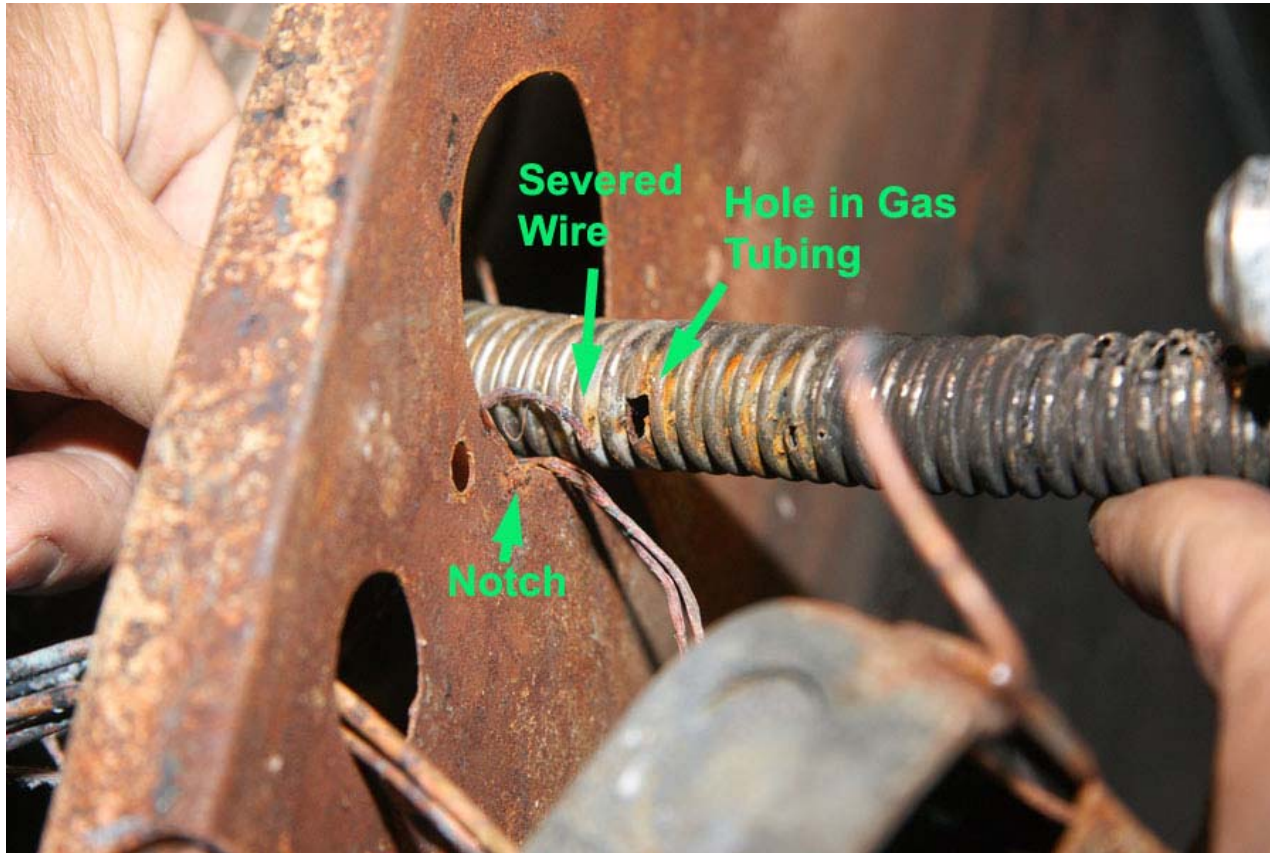

Figure 1. Multiple Fault Current Paths.

Case No.: F08-049



F08-049





## F08-049: Transformer Examination



F08-049: Transformer Examination



# Crossville, AL

























# Vestavia Hill, AL





















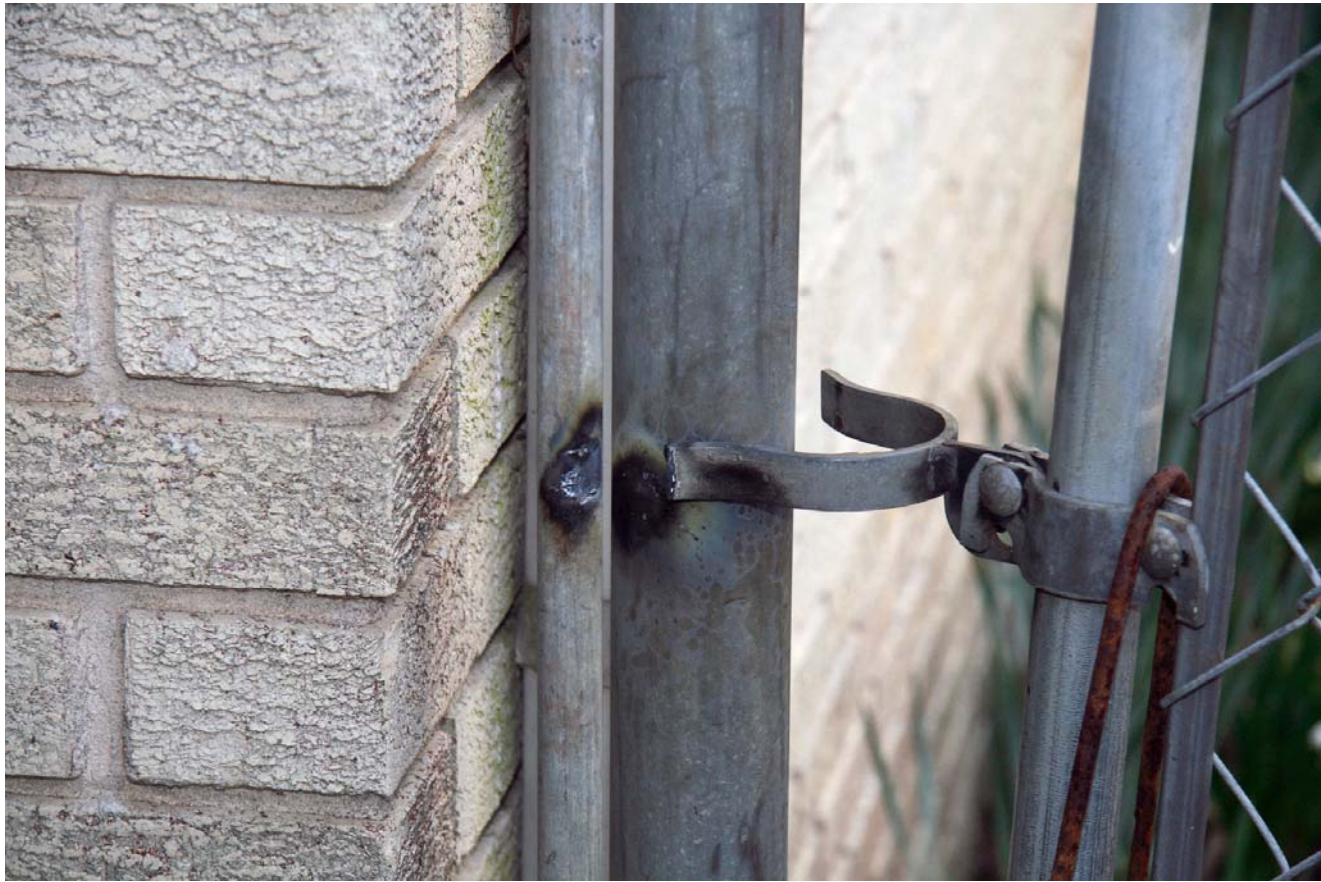





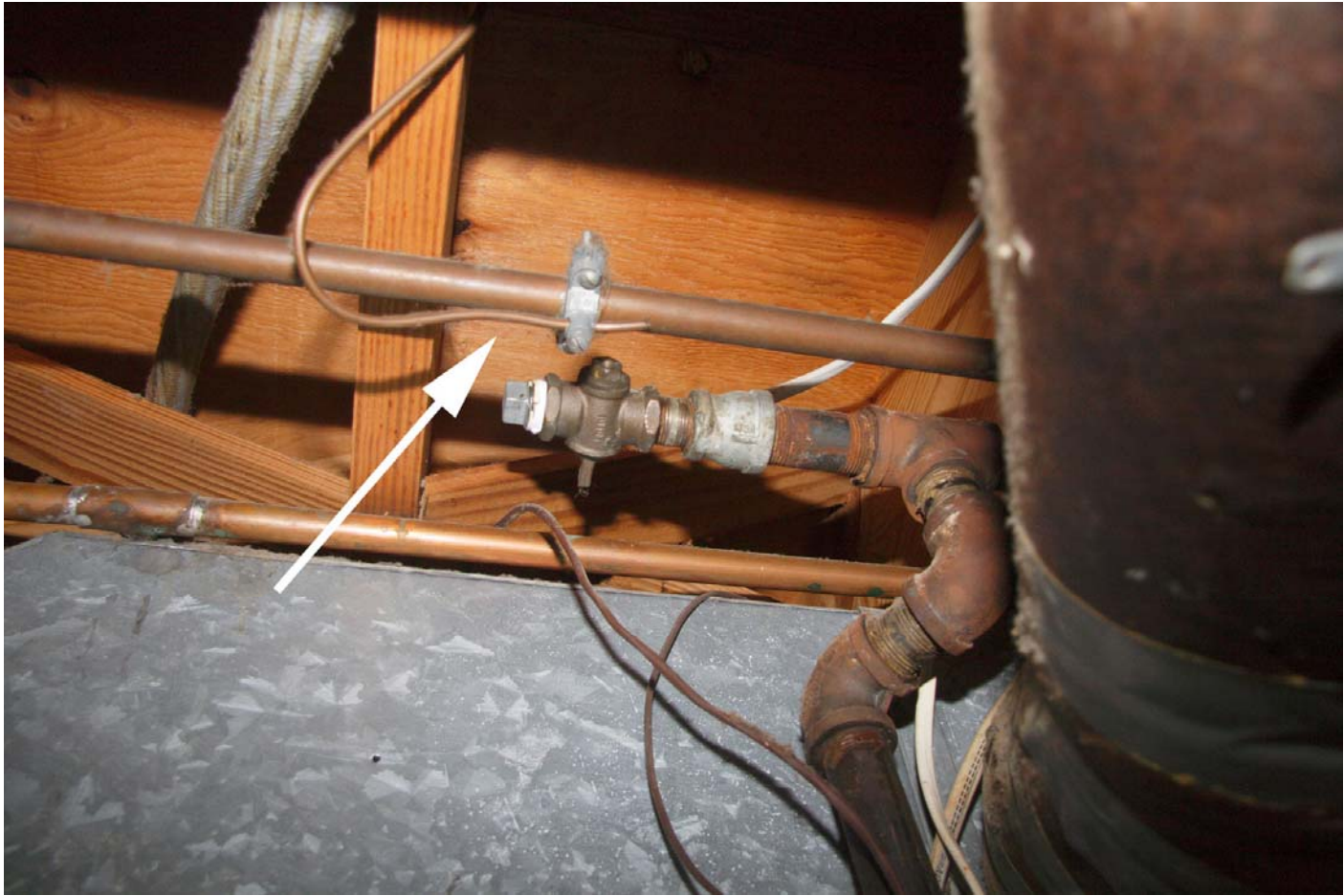

# Selmer TN

















# New Orleans, LA





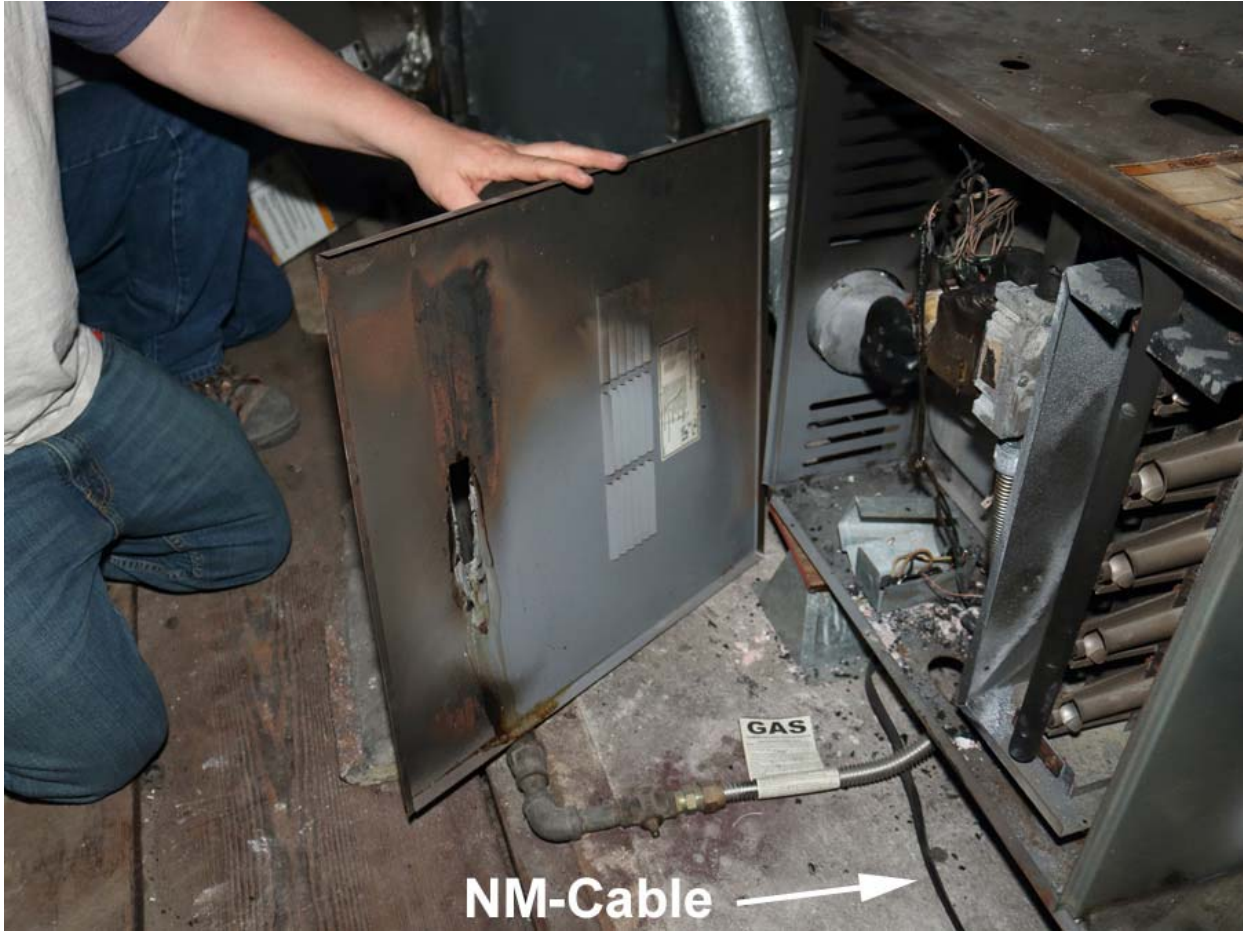

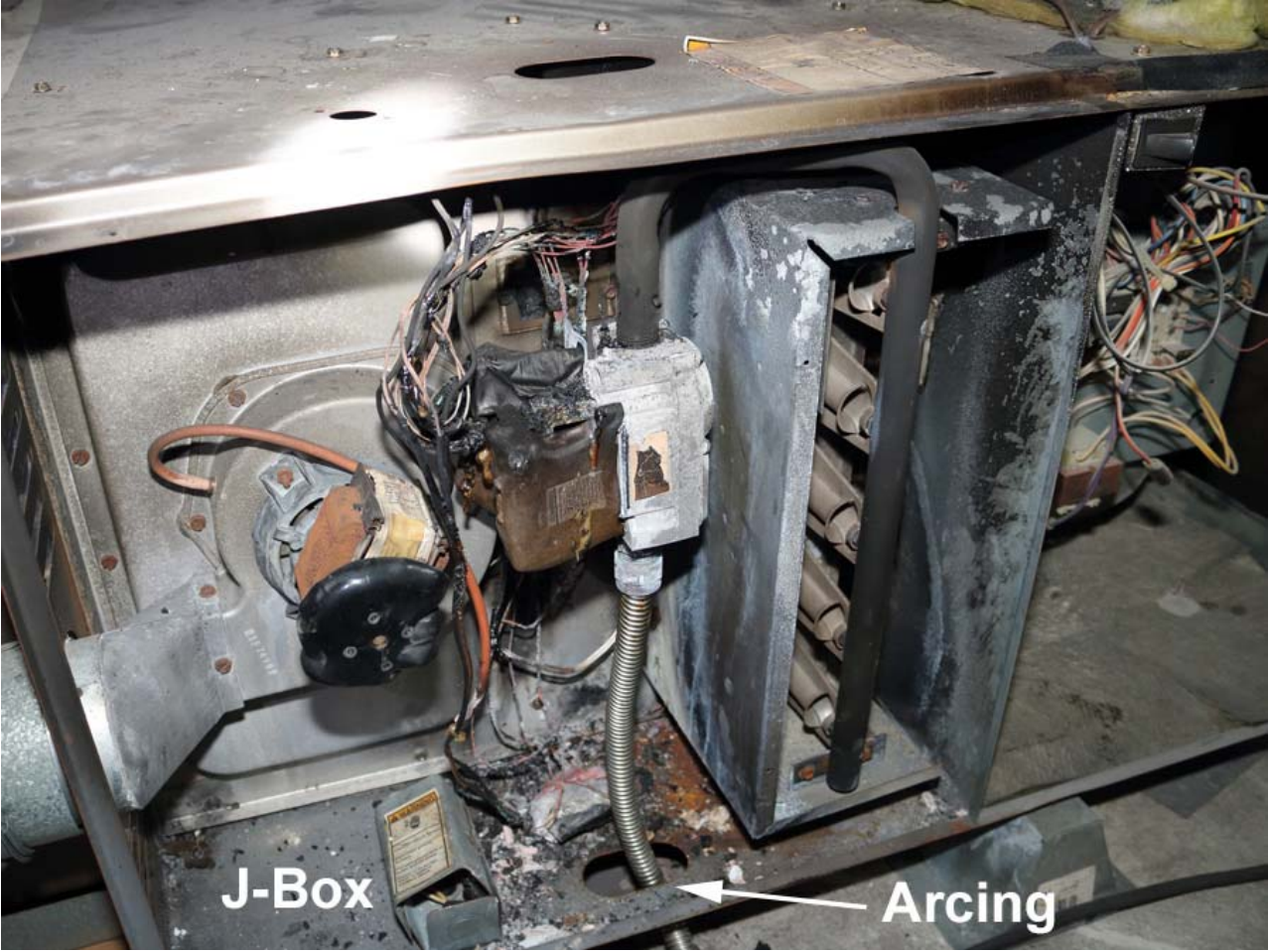









# F20-042 Vicksburg MS





Dishwasher

Damaged Water Supply Line

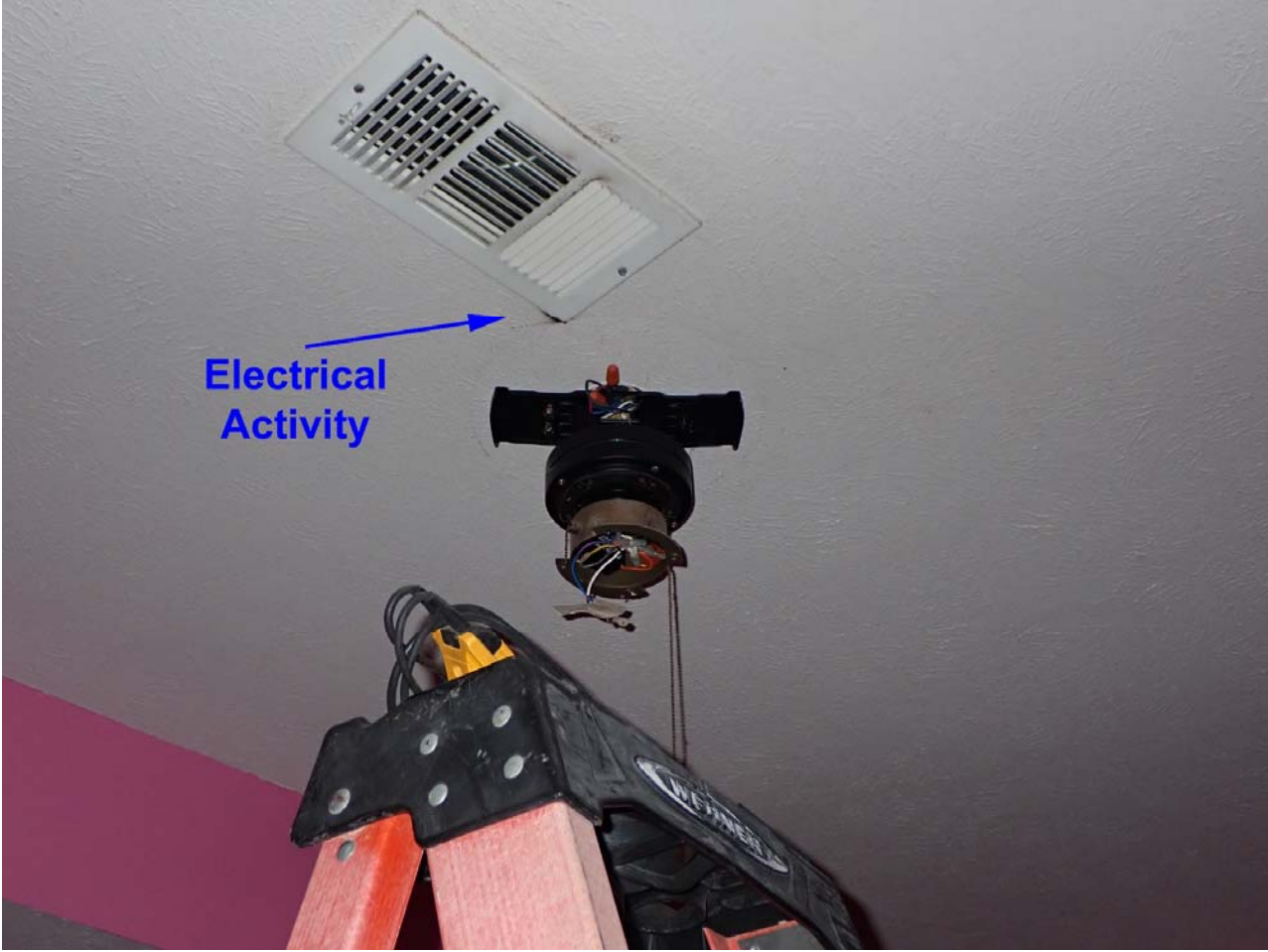

Electrical  
Activity

# OPEN NEUTRAL FAILURE

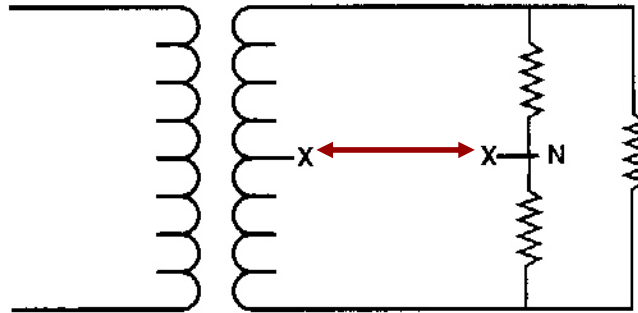

**A failure or loss of neutral results in the 120 volt loads being subjected to voltages between 0 to 240 volts. The actual voltage depends on how the system is balanced. I.e. how much load is on one leg of 120 volt compared to the other. The more the unbalance the more the unbalance of voltage. The 240 volt loads are not affected. Since the effects are very noticeable this type of condition does not persist long. Some effects of an open neutral are:**

**Lights - Burn bright and hot. Burn out very quickly**

**Heaters - May overheat, thermal protection shuts down heater**

**Motors - Overheat, some types may increase speed**

**Transformers - Overheat, devices connected to output may overheat or fail due to increased voltage**

**Wiring - No effect. Building wiring is rated for 600 volts.**



# Open or Floating Neutral

- NFPA 921 2021
- An electrical installation with an open neutral conductor will not have a fixed 120 V between each hot leg and the neutral. There will be 240 V between the two legs, but instead of the voltage of the two legs being fixed at 120 V to neutral each. The voltage may vary to some other values that add up to 240 V. The actual voltages in the legs will depend on the load on the two legs at any time. For example, the voltages might be 60 and 180.

Kirchhoff's Voltage Law: "The sum of the voltages around any closed loop is zero".

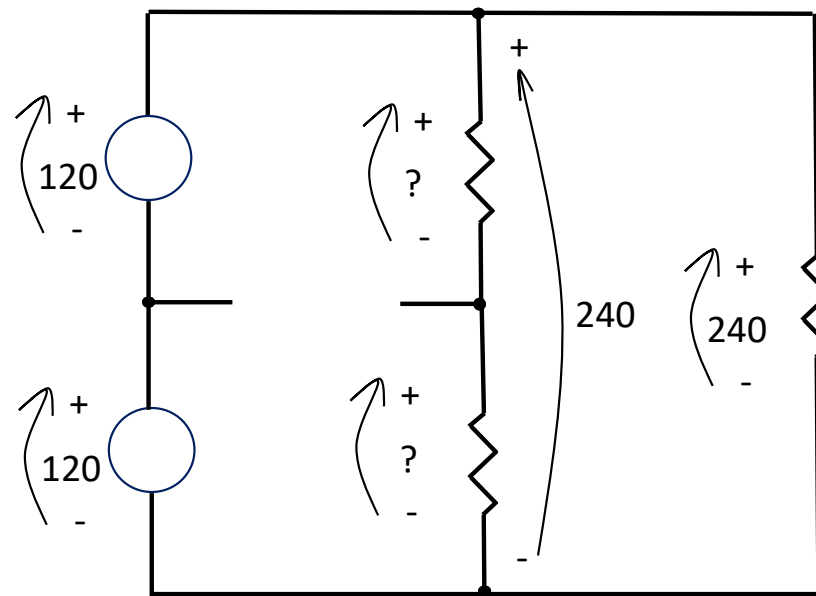

Open or Floating Neutral

# Brookhaven, MS



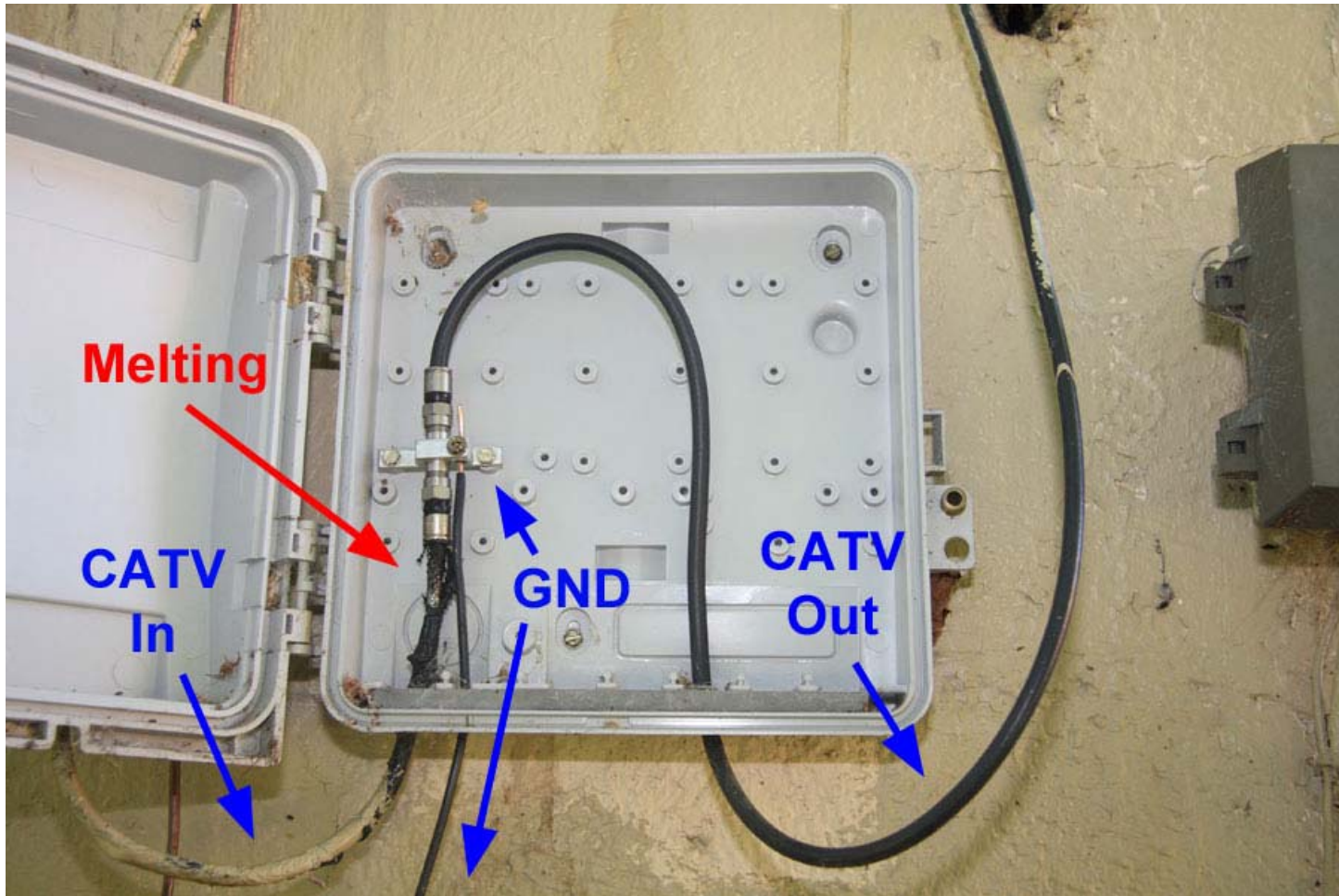





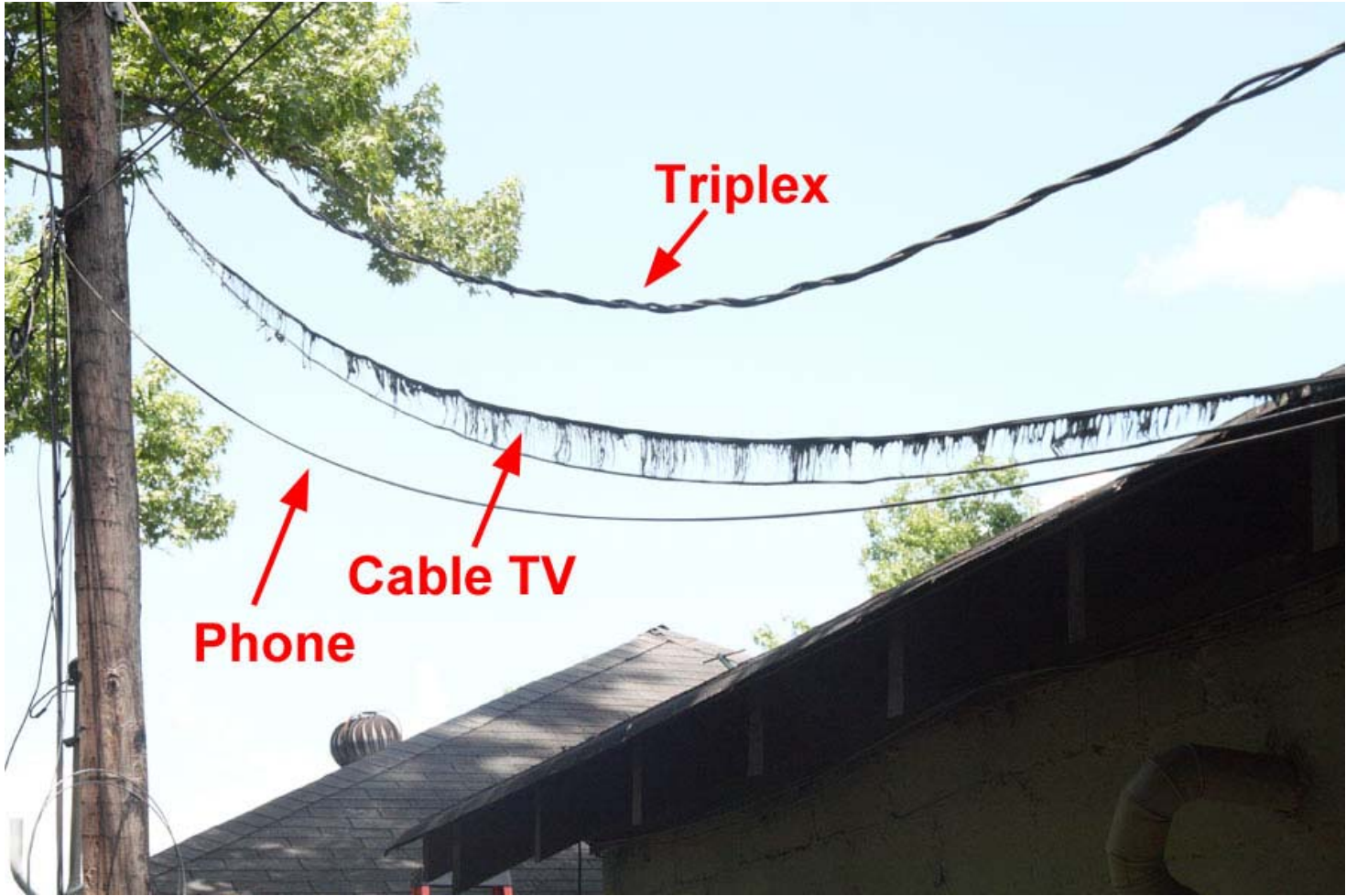

**Triplex**

**Phone**

**Cable TV**





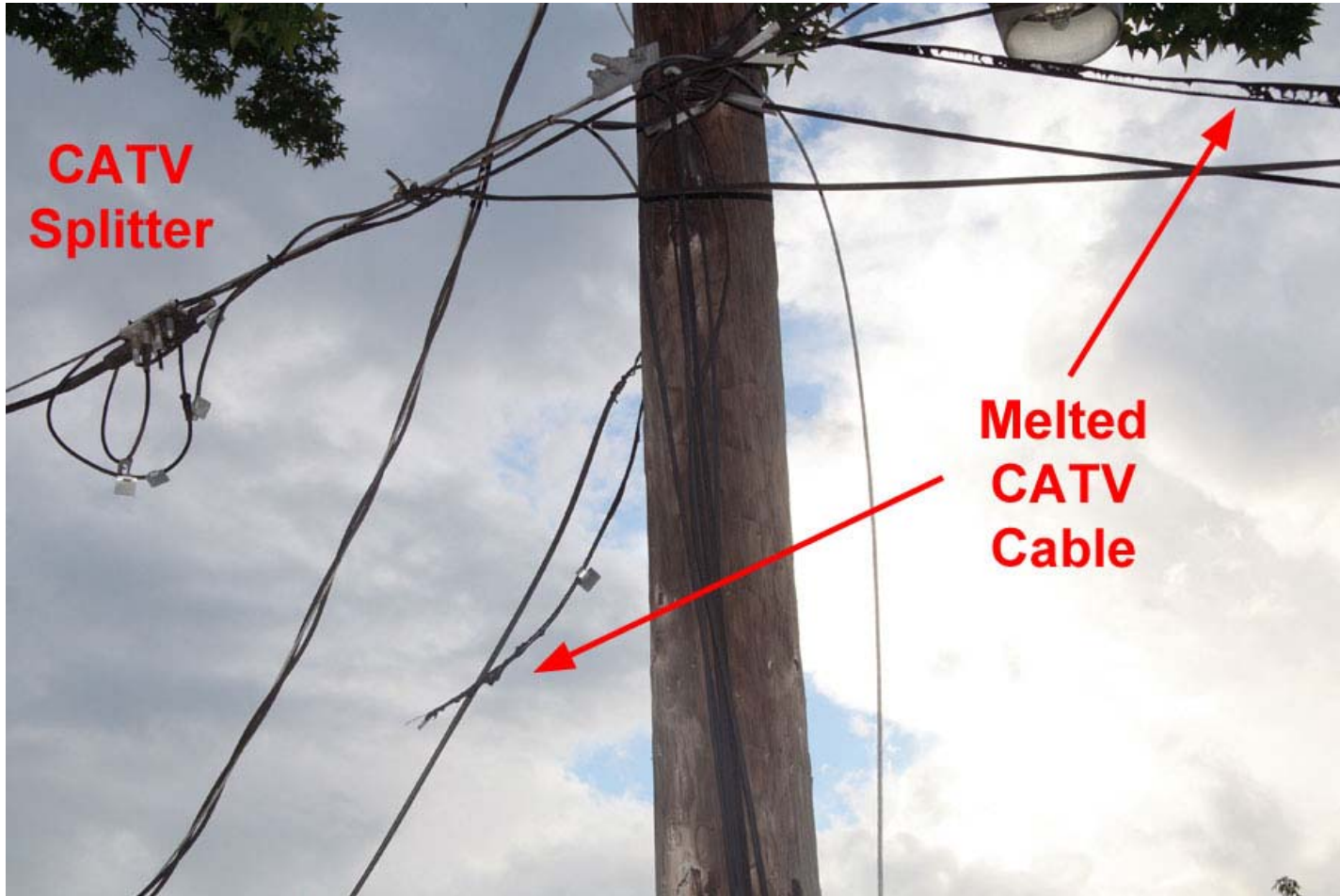

**CATV  
Splitter**

**Melted  
CATV  
Cable**





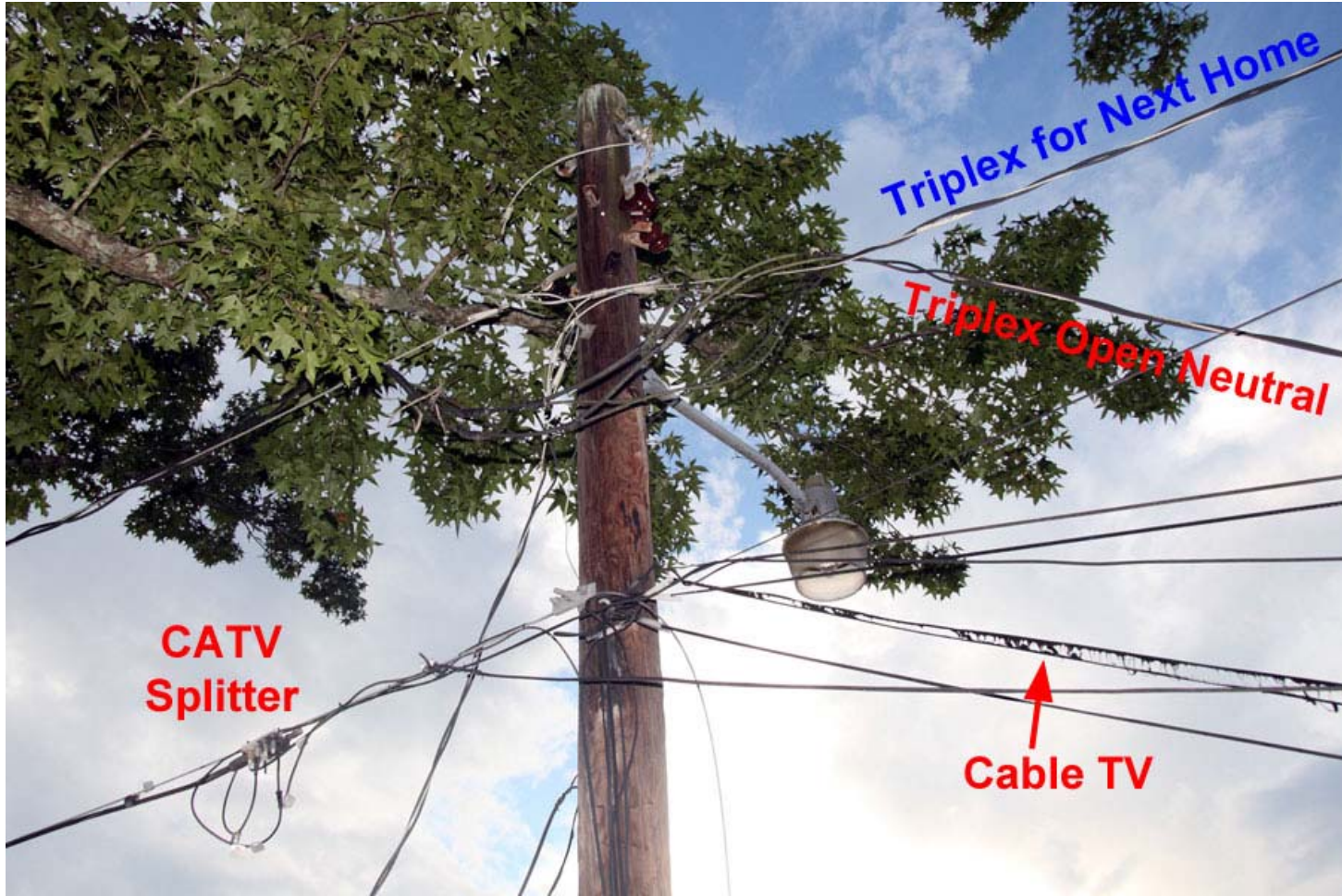

**CATV  
Splitter**

**Cable TV**

**Triplex for Next Home**

**Triplex Open Neutral**



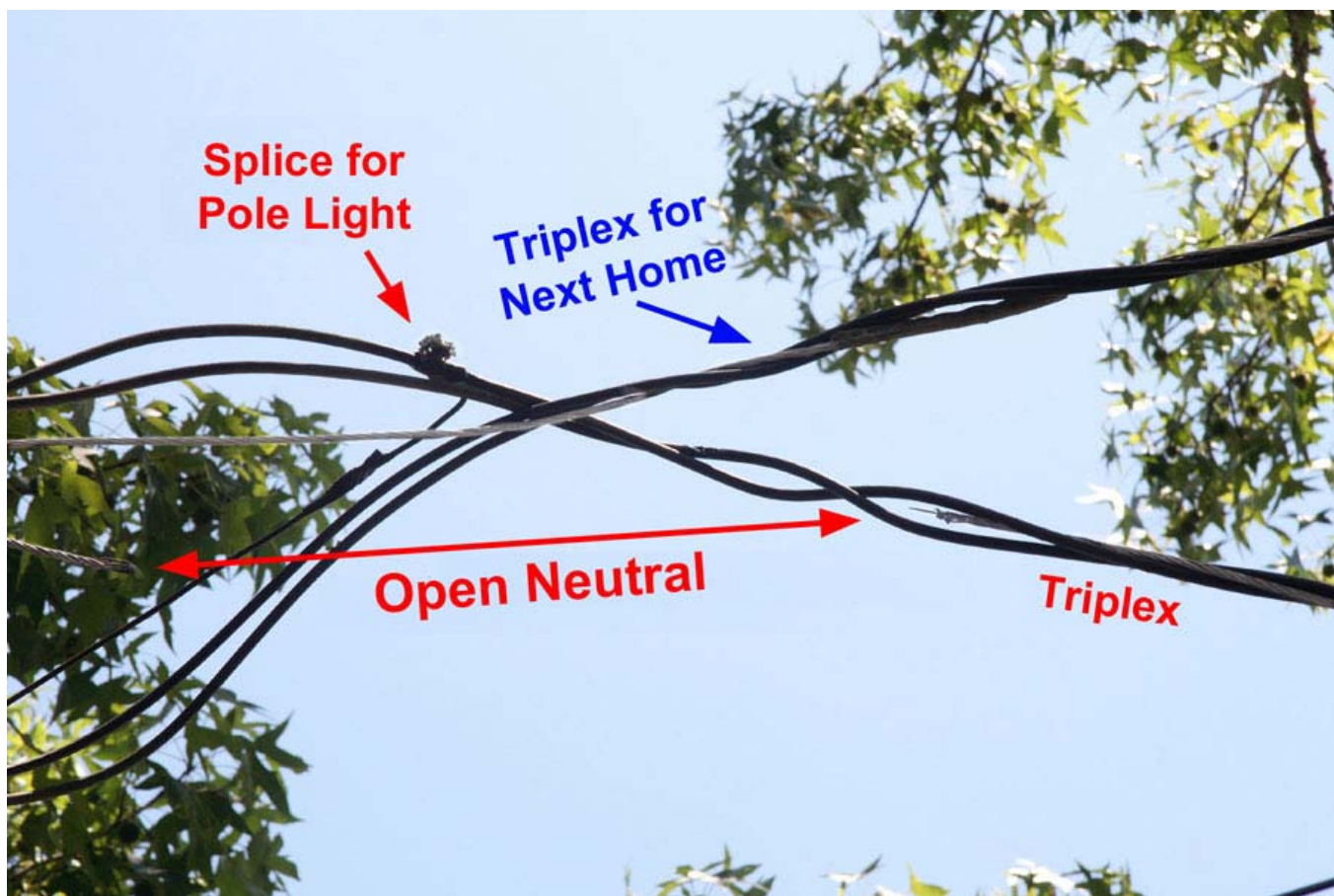

**Splice for Pole Light**

**Triplex for Next Home**

**Open Neutral**

**Triplex**

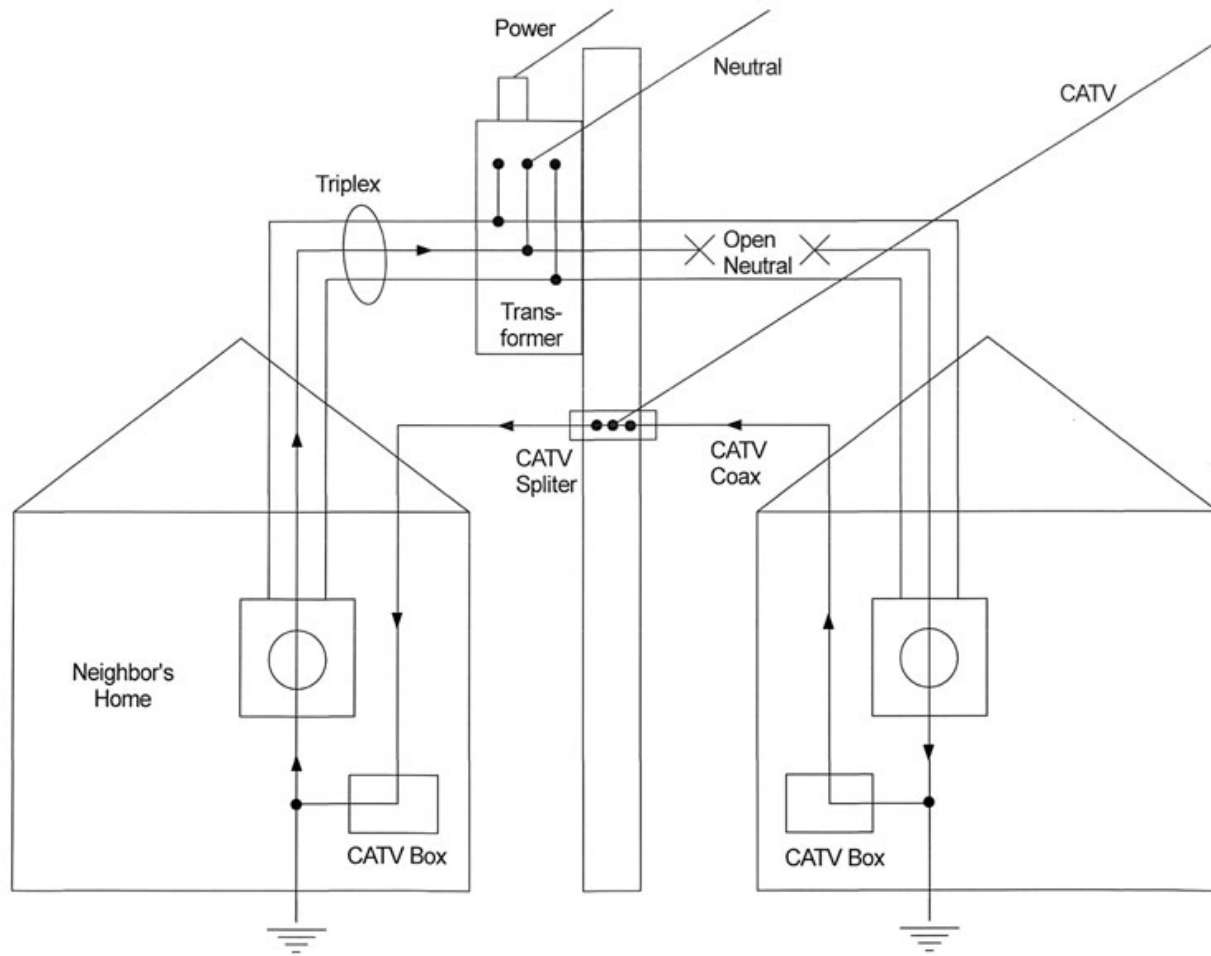



# Fires Inside the home

# Cooktop Fires







° SPI2YA

° 208/240V 940/1250W °

° CHROMALOX







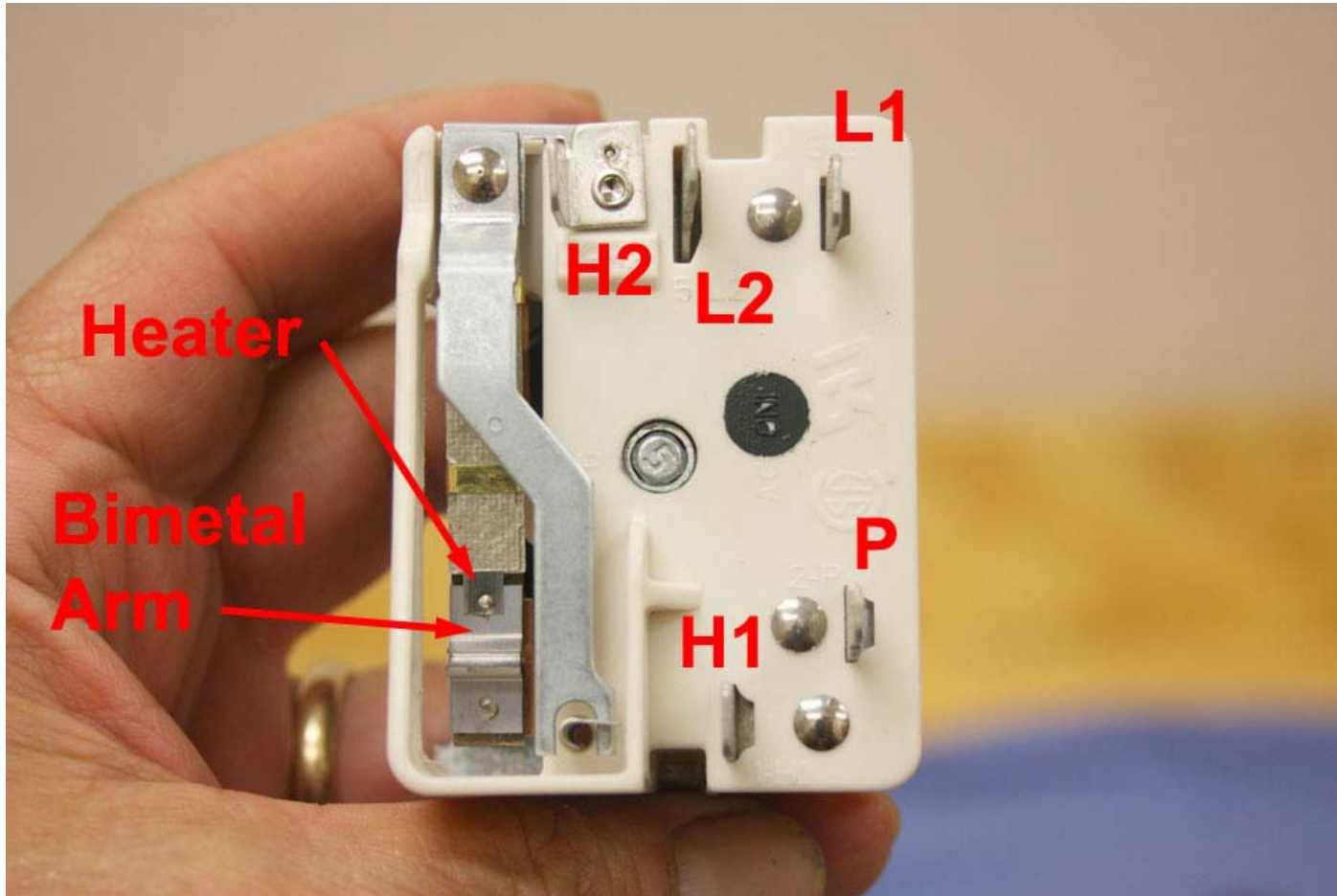

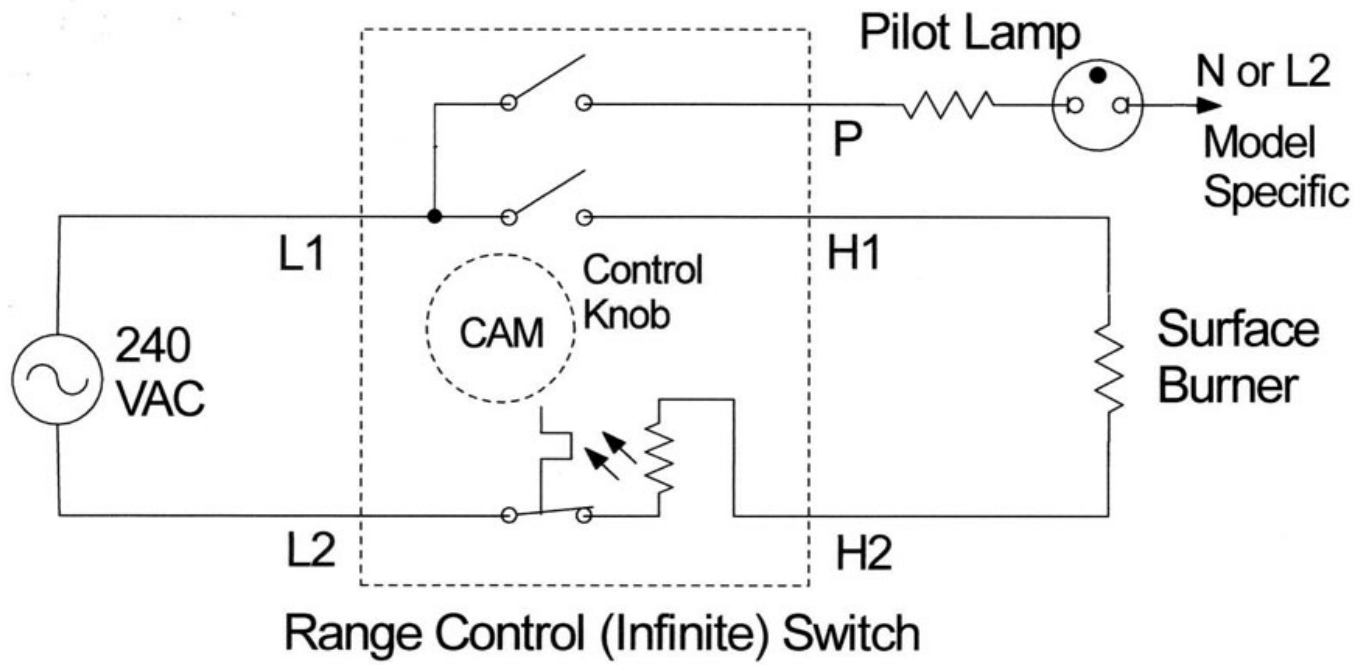



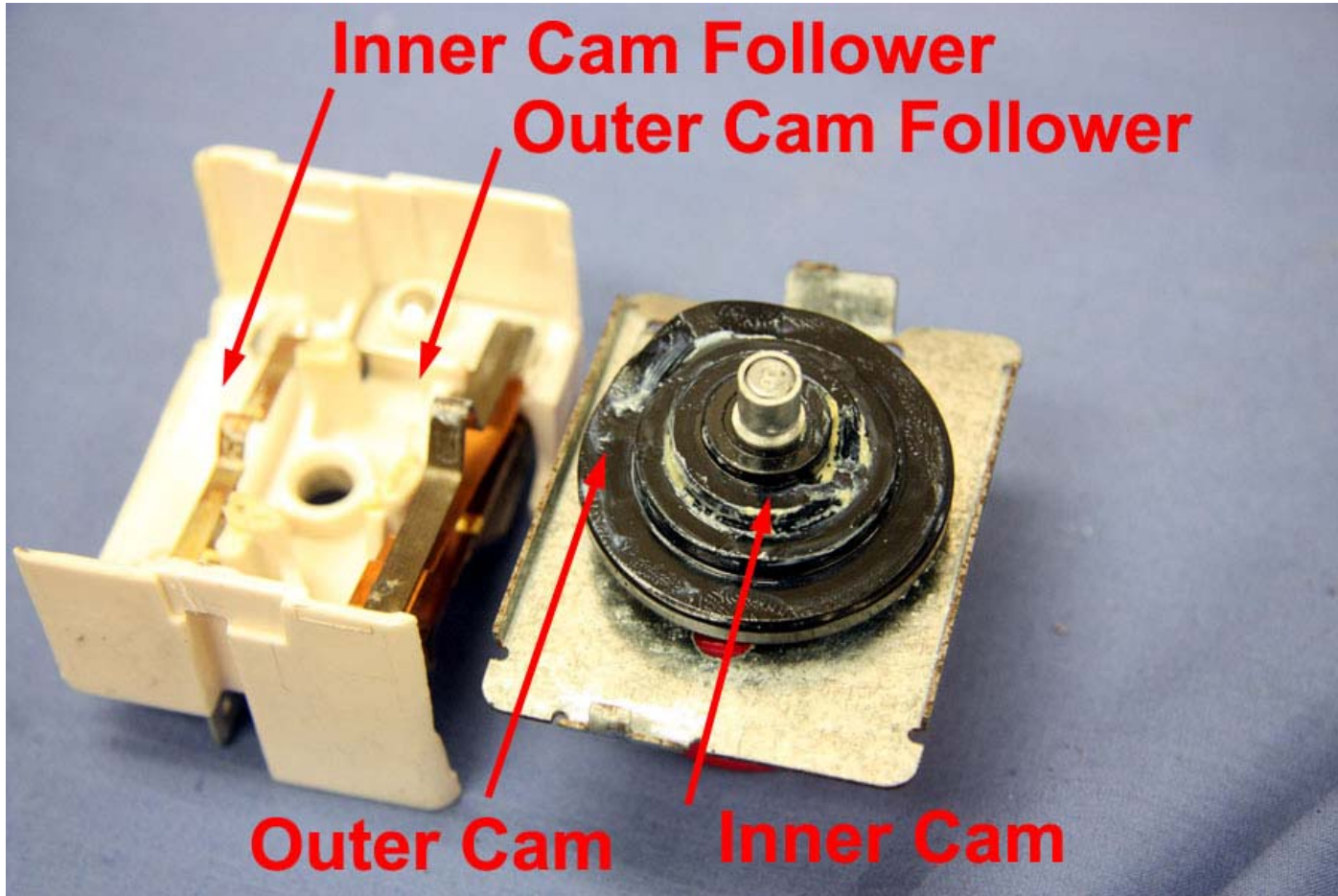

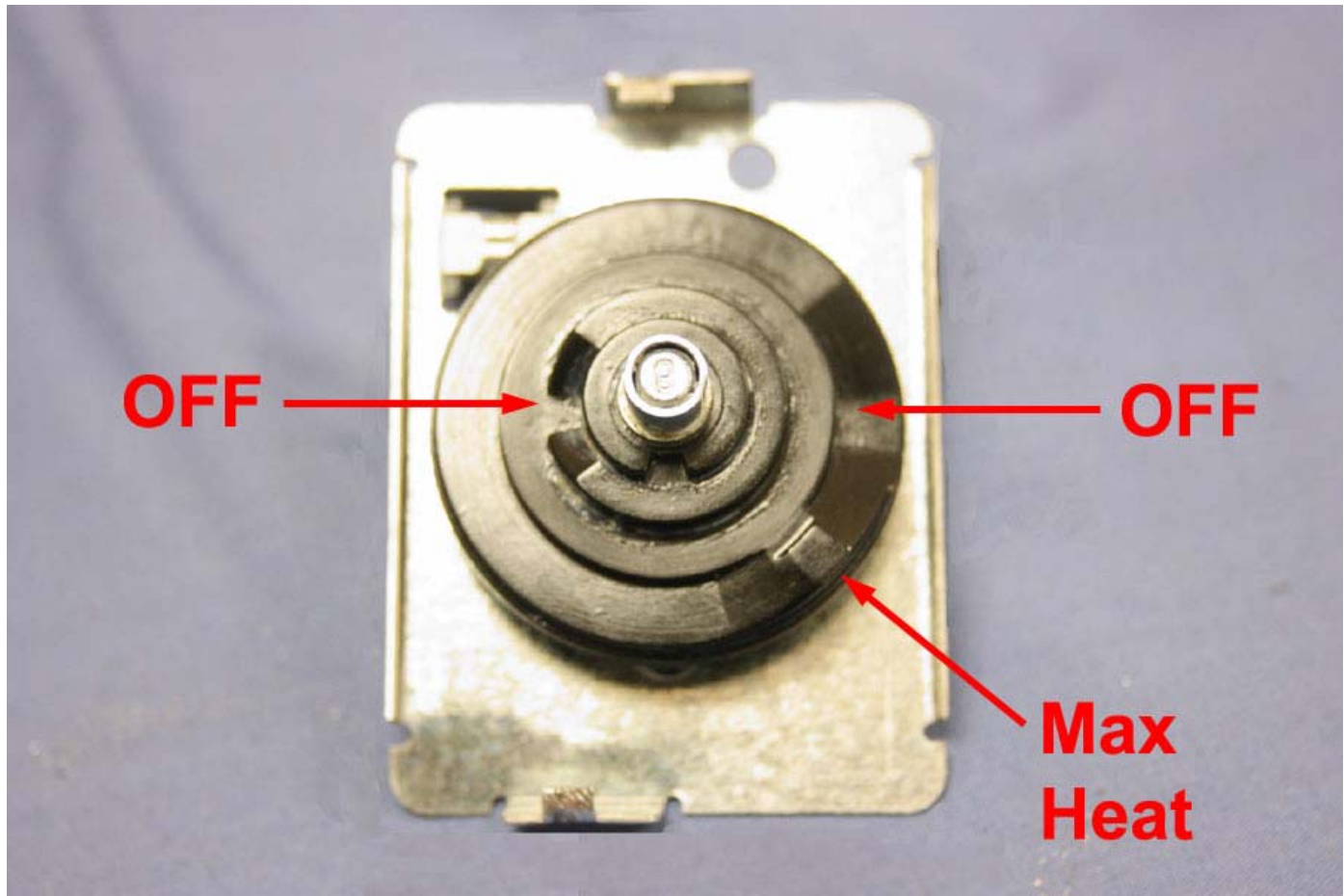

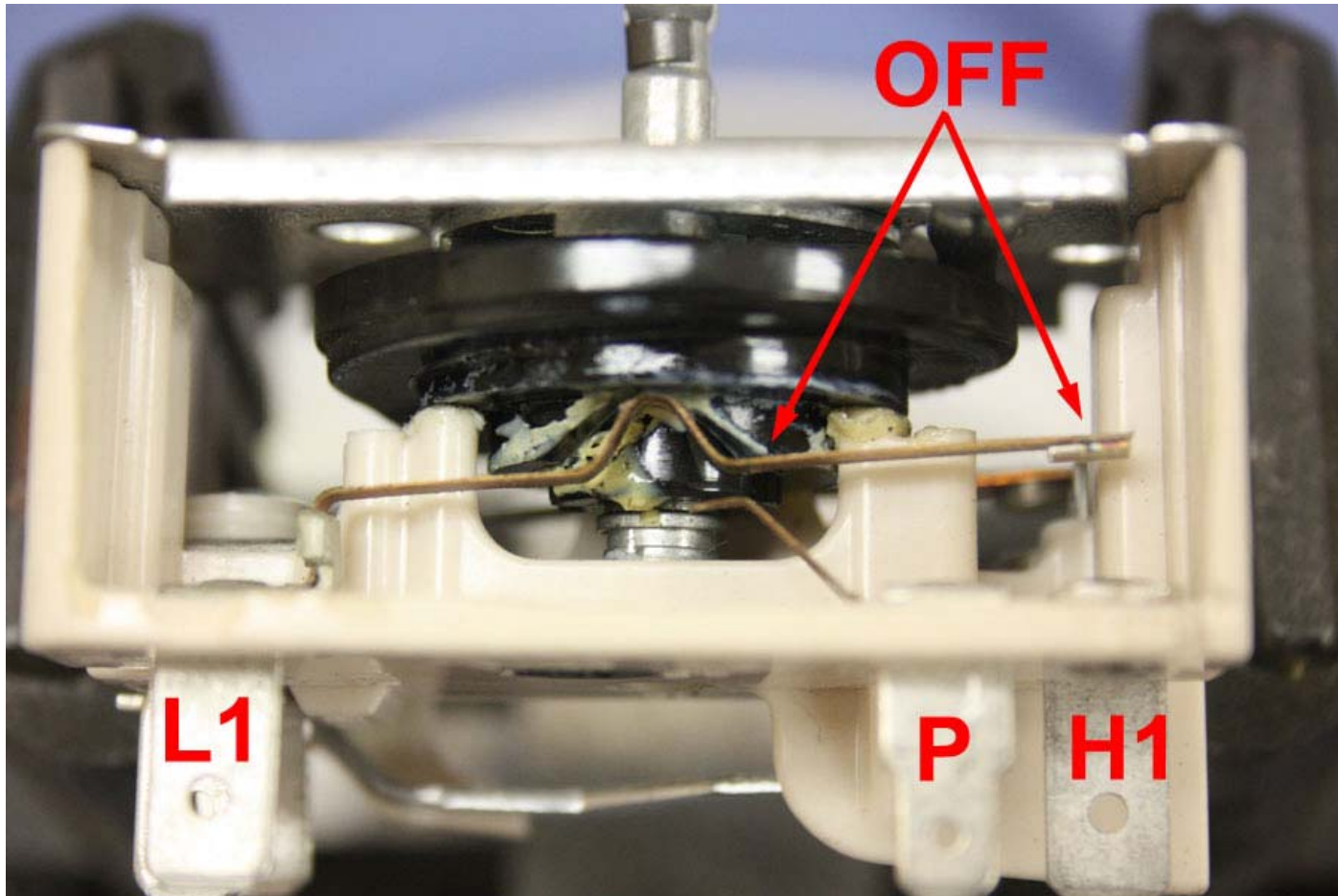

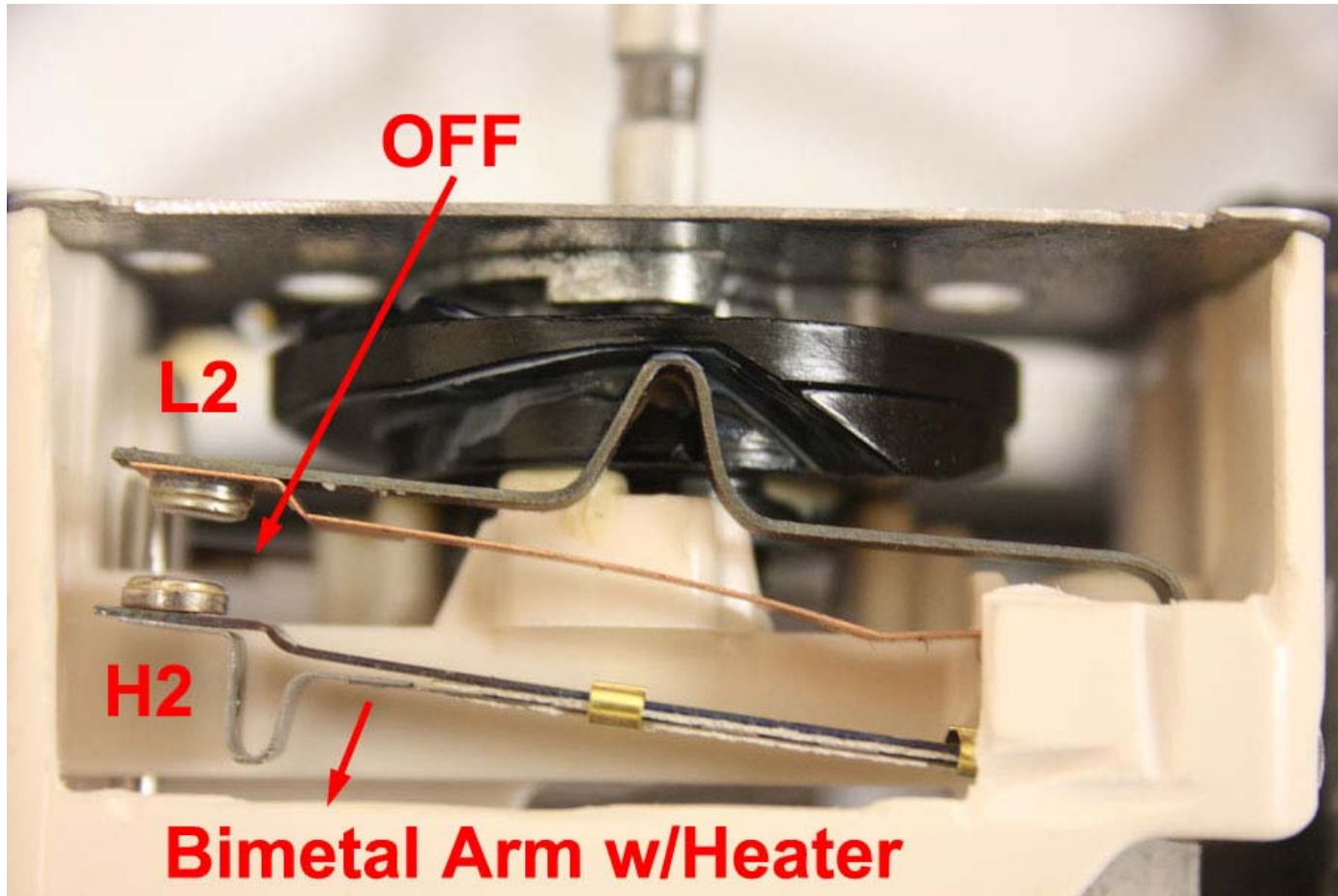



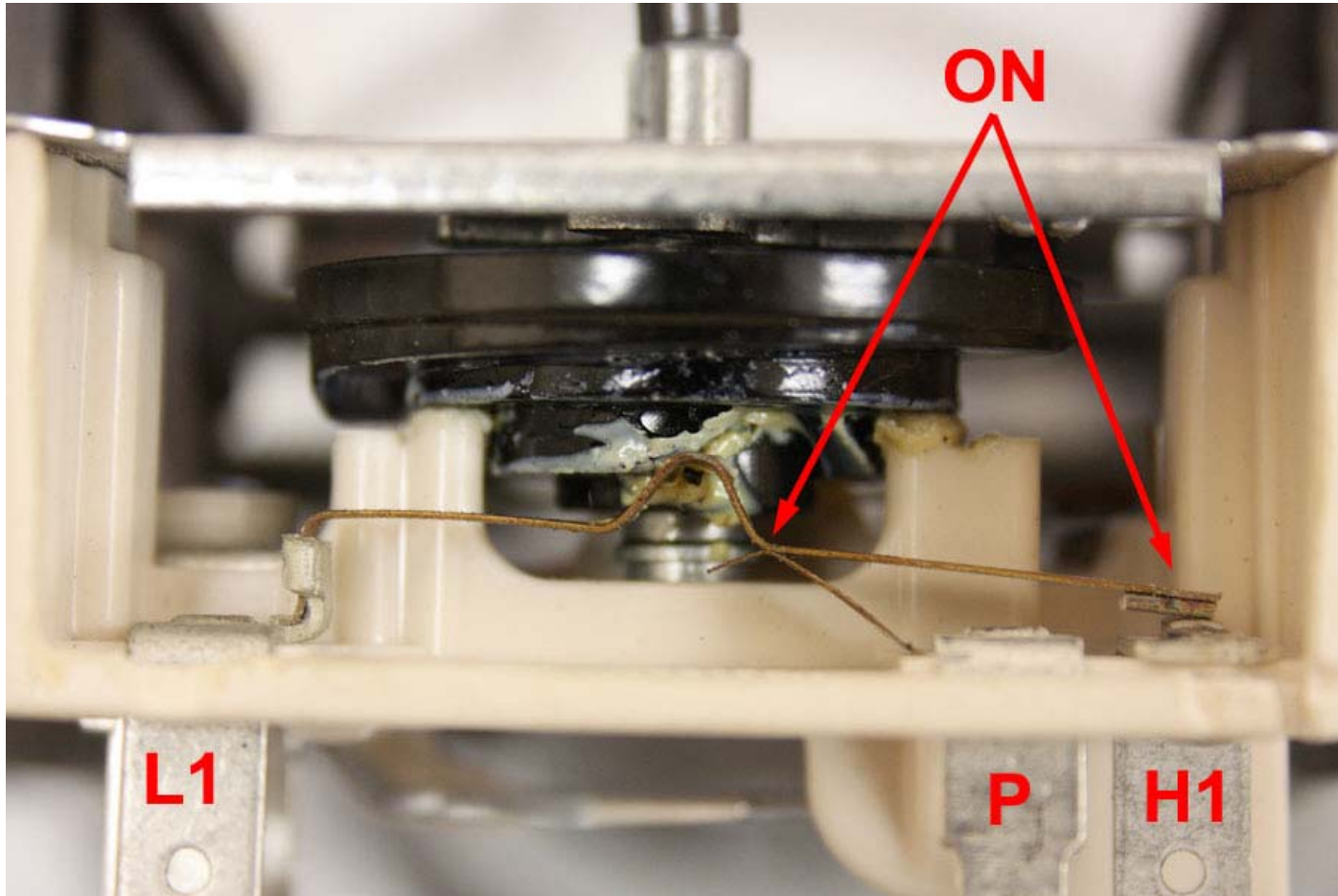

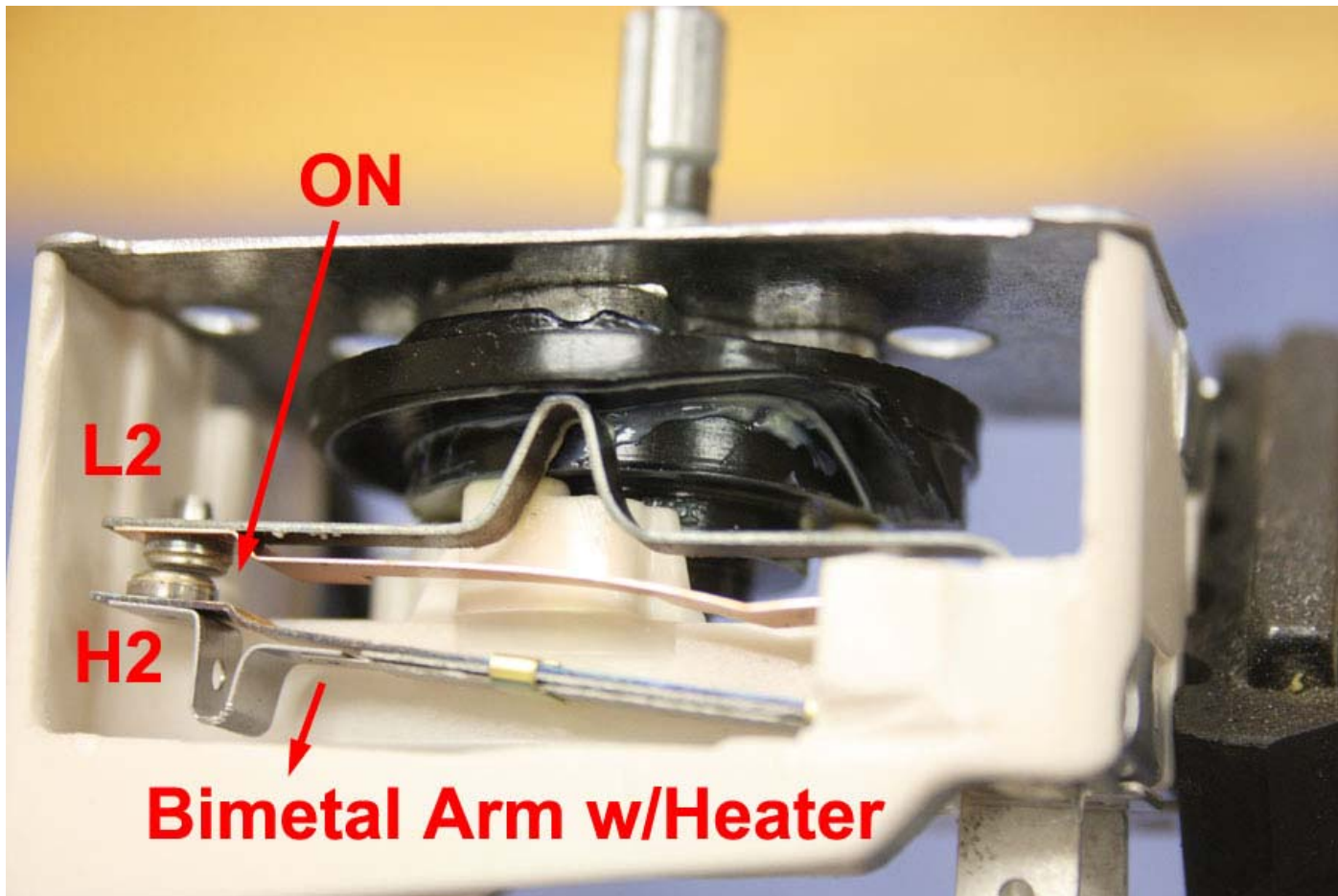

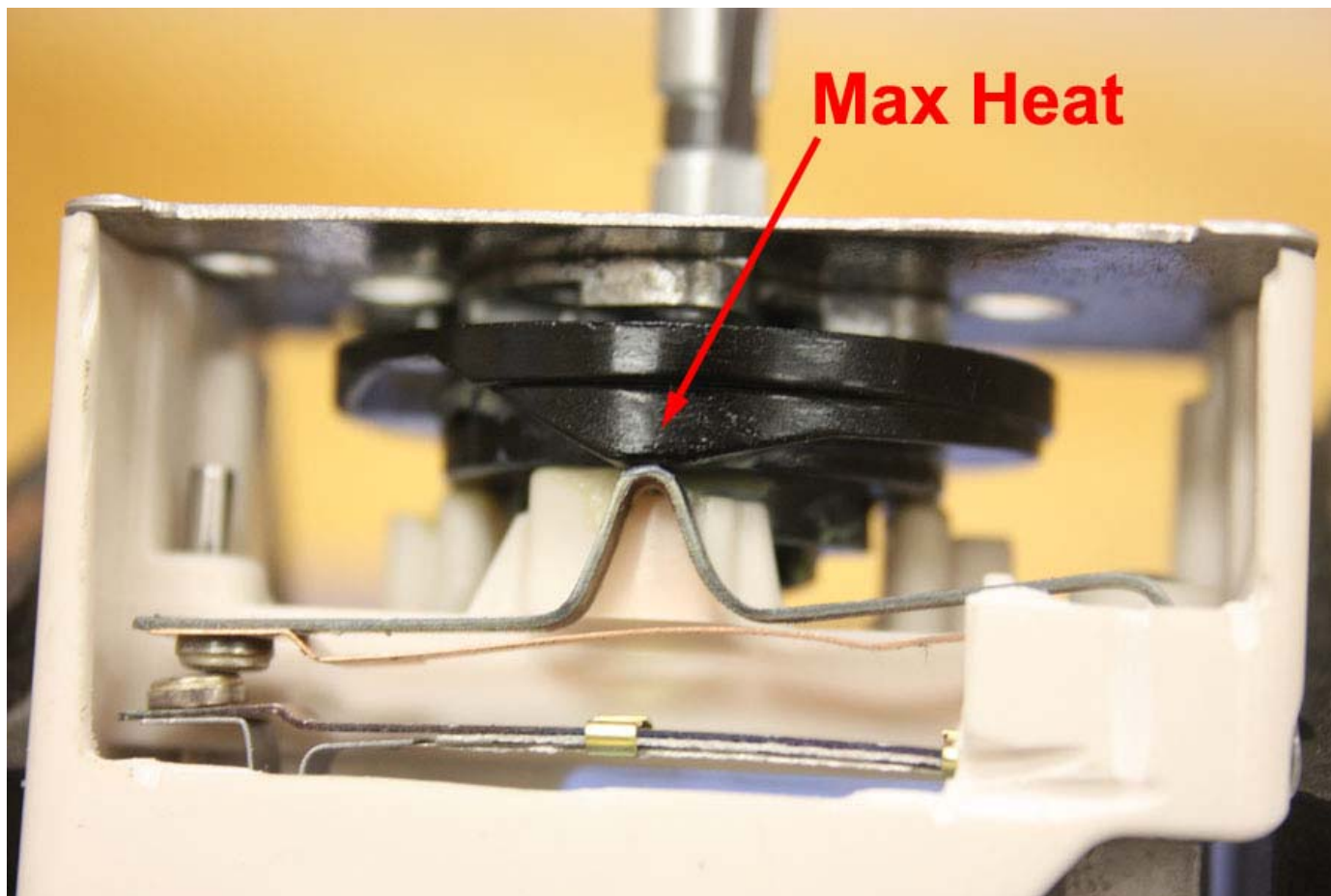







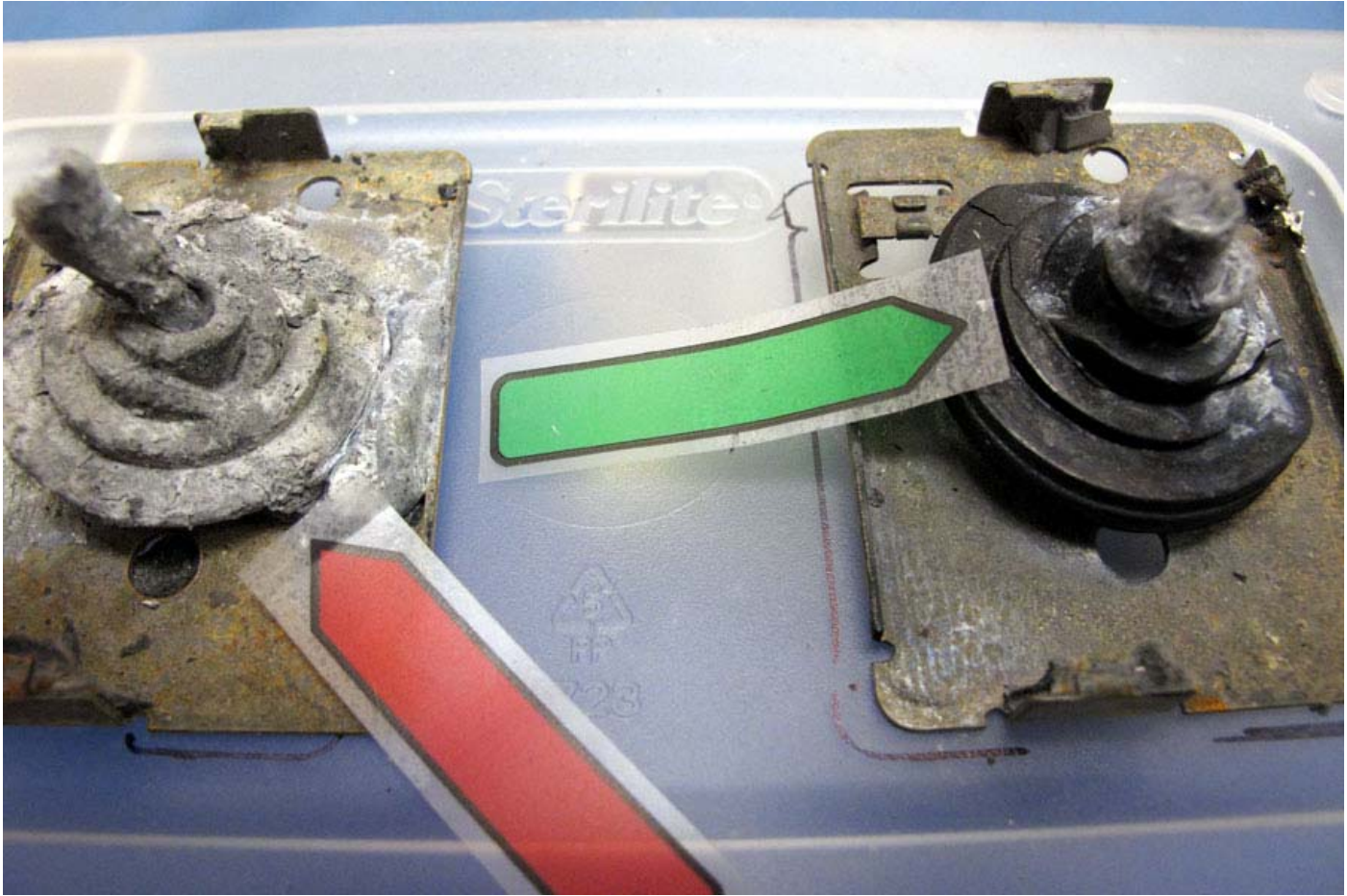



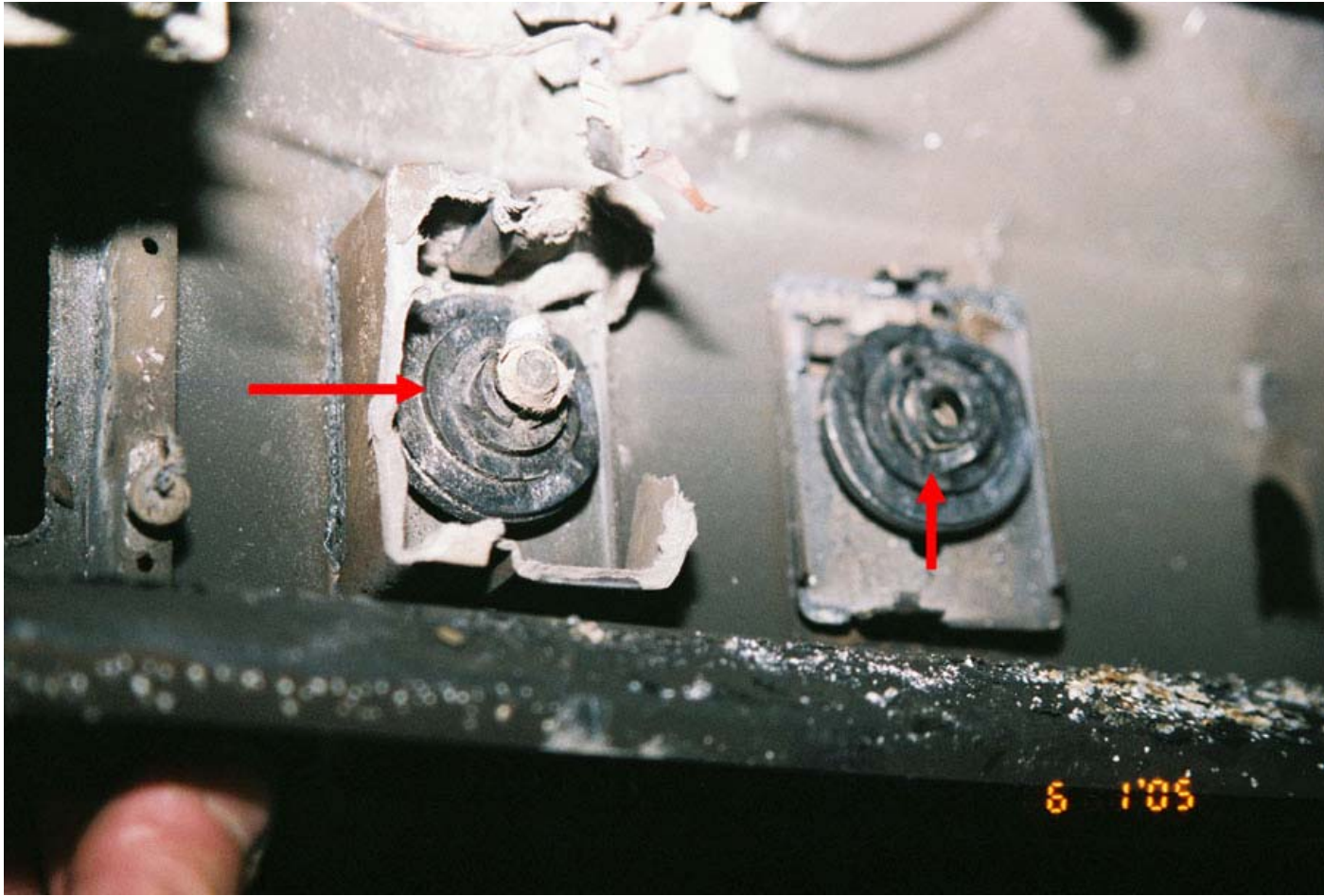





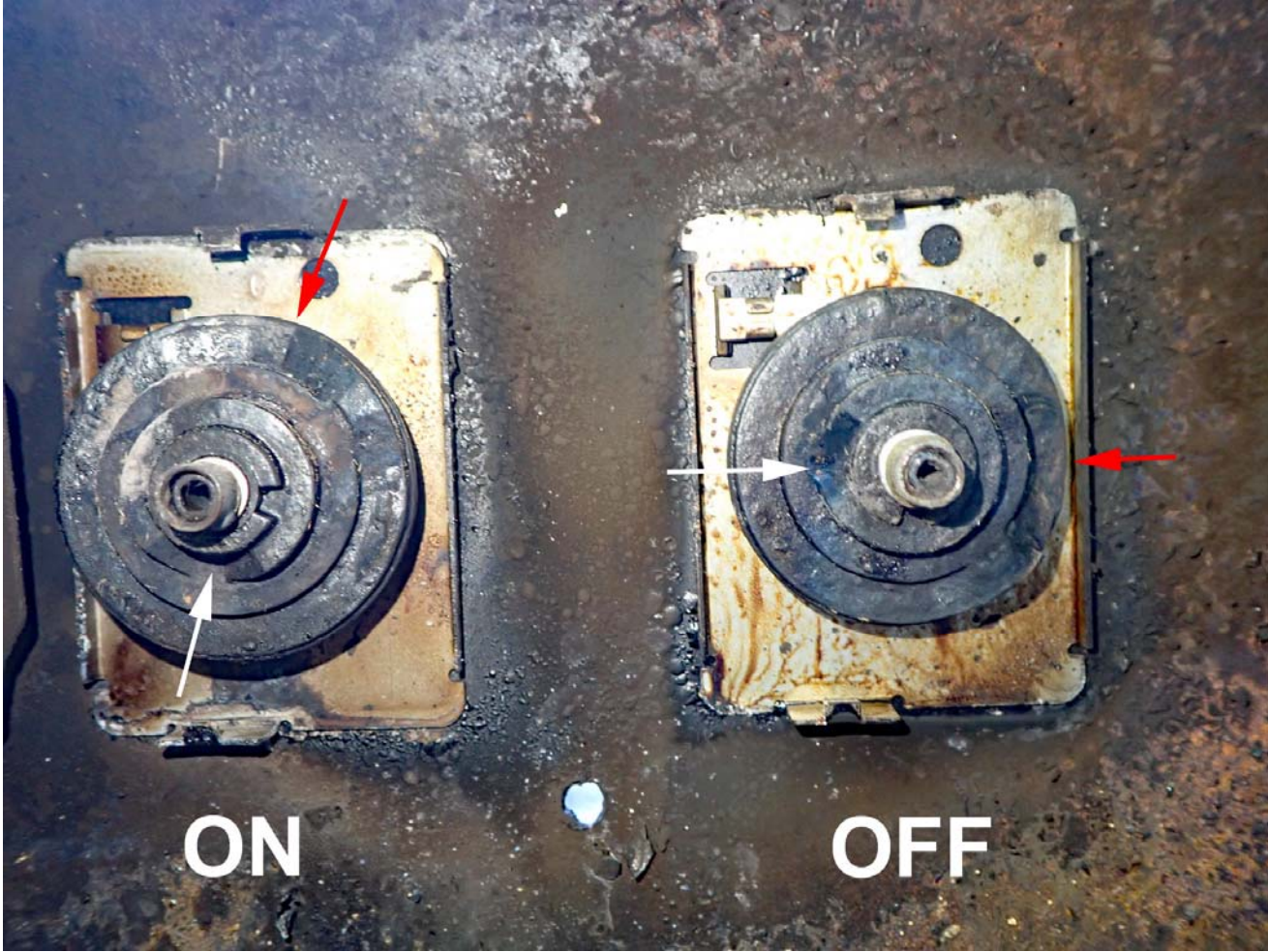

ON

OFF

# Birmingham, AL







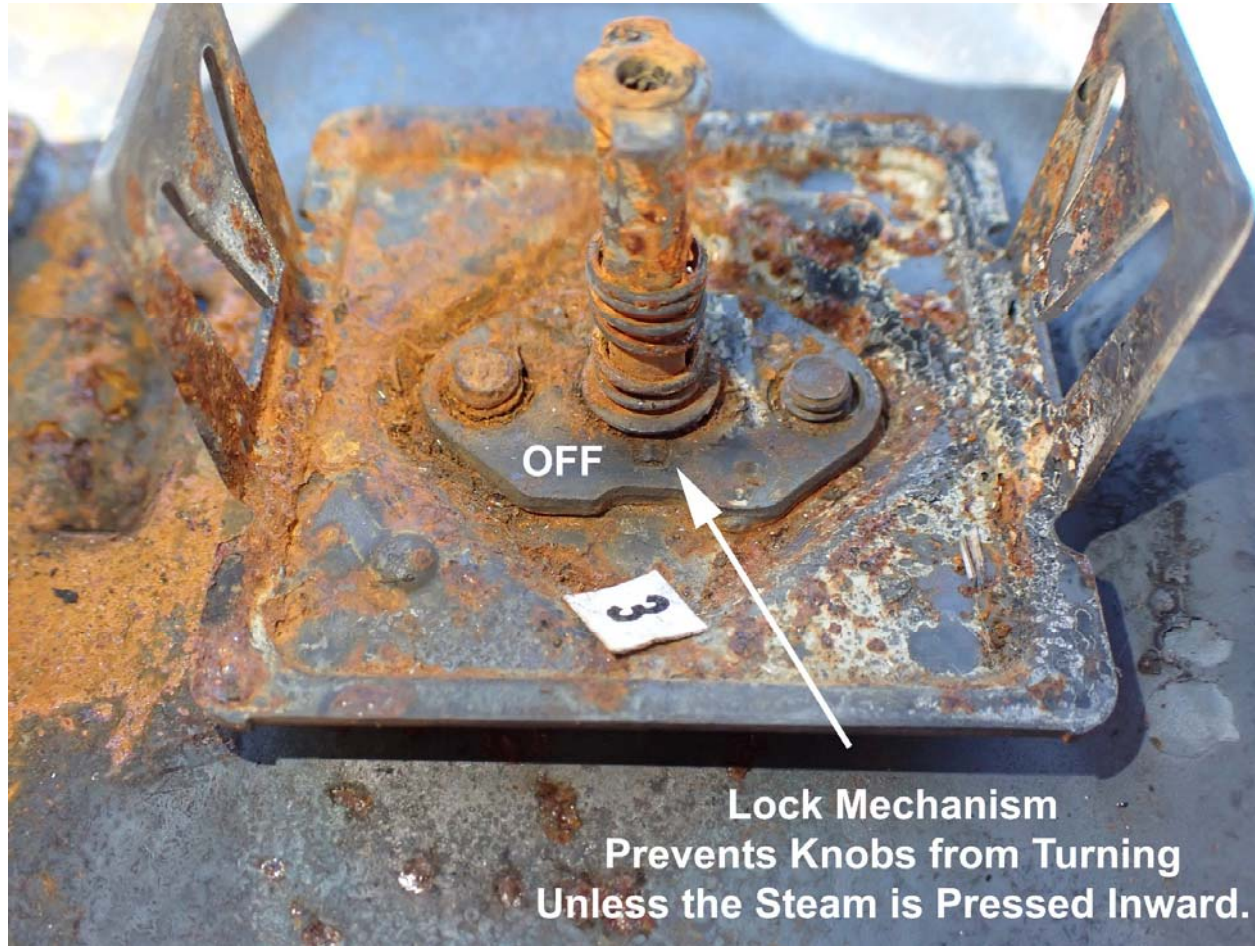

**Lock Mechanism  
Prevents Knobs from Turning  
Unless the Steam is Pressed Inward.**



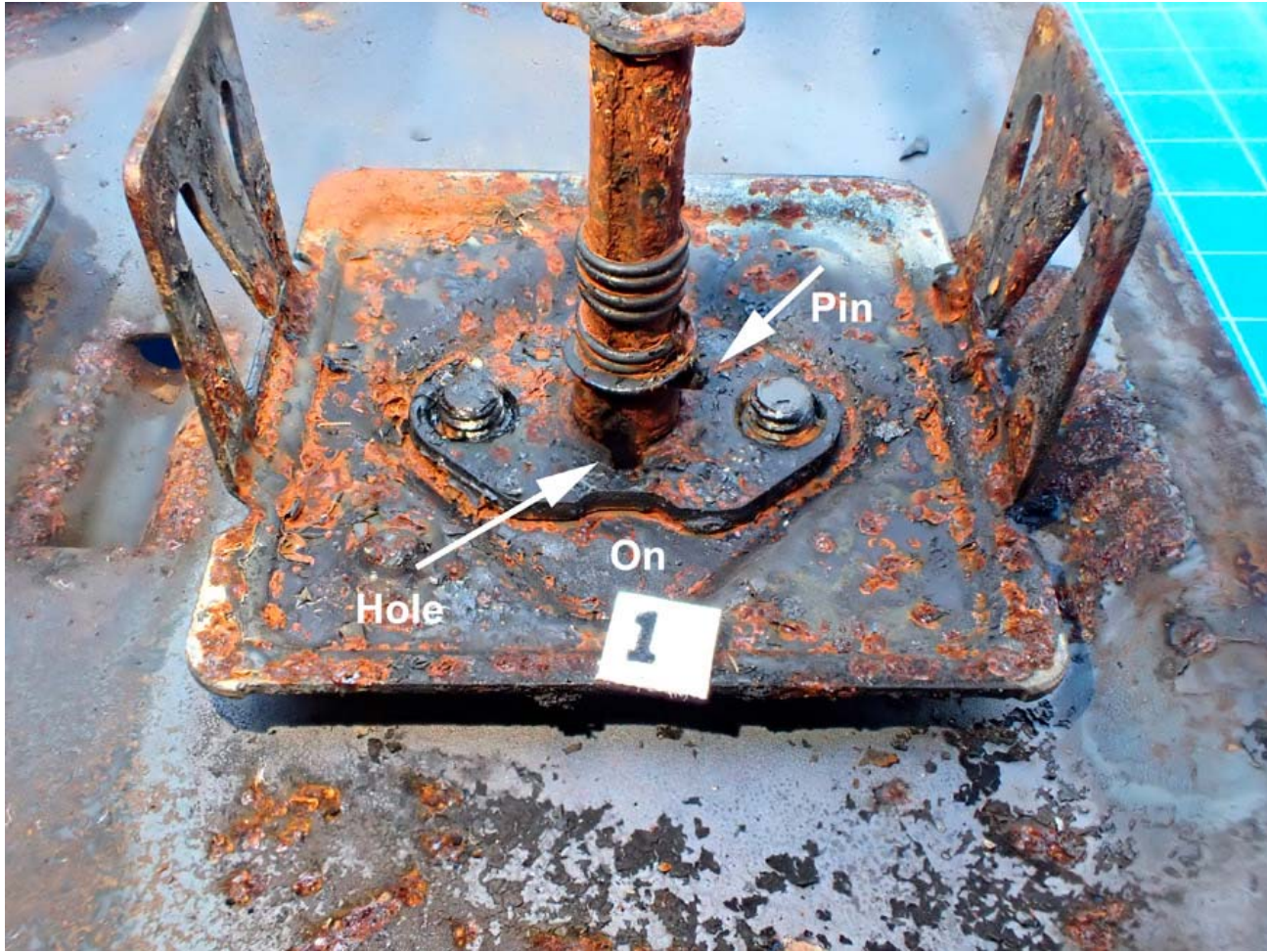

# Electrical Arcing



# IGNITION ENERGY OF AN ARC

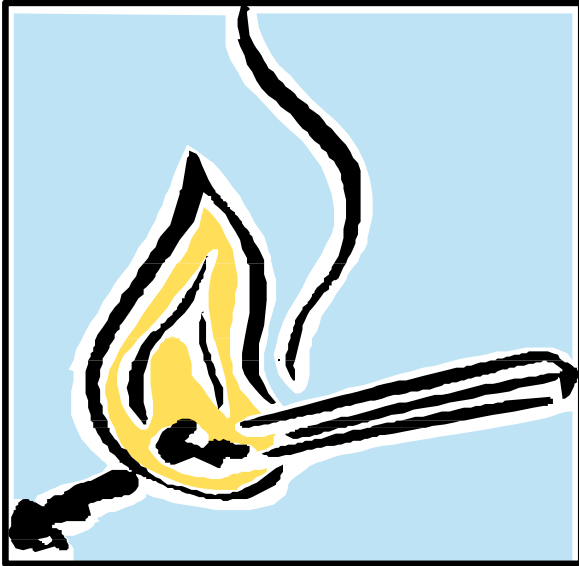

- The ignition energy of an arc, or its potential to cause ignition, is the equivalent of one lit match for one second.

Can not ignite a wood beam 2x4

# Melting Temperatures of Metals

Zinc	707°
Aluminum	1220°F
*Yellow Brass	1710°F
Copper	1981°F
*Carbon Steel	2760°F

Yellow Brass is an alloy – 60% Copper and 40% Zinc  
Carbon Steel is alloy of Iron and Carbon (<2%)



- Test Question?
- Copper Melts at:
  - A) 1220 °F
  - B) 2750 °F
  - C) 1981 °F
  - D) 787 °F
  - E) 3380 °F

Ans. C

# WIRING MALFUNCTIONS

- Arcing or beading marks on the conductor.
  - Attempt to identify how they were formed.
  - Beading on a conductor is NOT a sole indicator the fire was electrical in nature.
- Electrical beading indicates that the circuit was energized.

# Arcing verses Fire Melting

- Arcing

- Usually last less than 1 second
- Temperatures between 3,600°F & 7,200°F

## Fire Melting

- Usually last minutes or longer
- Max Temperature between 1,600°F & 2,000°F

### Melting Caused by Electrical Arcing (2014 921-9.11.1.1)





1. Sharp demarcation between damaged and undamaged area
2. Round, smooth shape of artifact
3. Localized Point of contact
4. Identifiable corresponding area of damage on the opposing wire.
5. Locally enlarged grain size.
6. Resolidification of waves
7. Copper drawing lines visible outside of damaged area
8. Localized round depressions.
9. Small beads and divots over a limited area
10. High internal porosity when viewed in a cross-section

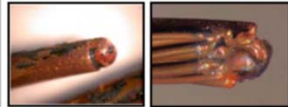
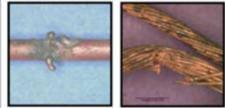

### Melting Caused by Fire (2014 921.9.11.2)

1. Visible effects of gravity on artifact
2. Extended area of damage without a sharp demarcation from undamaged material.
3. Gradual necking of the conductor (assuming this is not due mechanical break).
4. Low internal porosity when viewed in a cross-section.

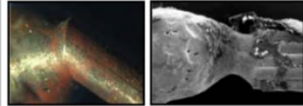
ATF Technical Bulletin 001 September 28, 2012  
 Visual Characteristics of Fire Melting on Copper Conductors

<b>Table 1</b> <b>Characteristics of Arc Beads</b>	
	Sharp Line of Demarcation between damaged and undamaged area (Photos by Kevin Lewis / E. C. BUC)
	Round Smooth Shape (Photos by Nick Cary / Kevin Lewis)
	Localized Point of Contact (Photos by Kevin Lewis / E.C. Buc)
	Identifiable Corresponding Area of Damage on Opposing Conductor (Photo by Kevin Lewis)
	Copper Drawing Lines Visible Outside the Damaged Area (Photos by Kevin Lewis)
	Localized Round Depressions (Photos by David Reiter / Kevin Lewis)
	Small Beads and Divots Over a Small Area (Photo by Nick Carey)





NFPA 2014 – 9.11.1.1

Adds:

- Resolidification Waves
- Locally enlarged grain size
- High internal porosity when viewed in cross-section

# ATF Technical Bulletin

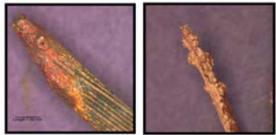
**Table 2**  
**Characteristics of Melt Globules**

	Extended Area of Damage Without a Sharp Line of Demarcation from Undamaged Material (Photos by Yasuki Hagimoto / E. C. Buc)
	Visible Effects of Gravity in the Artifact (Photo by Stephen Andrews)
	Blisters on the Surface (Photos by E. C. Buc)
	Gradual Necking of the Conductor (Photo by Jeremy Neagle)
	Non-Localized Loss of Integrity of Individual Strands on a Stranded Conductor (Photo by Michael Keller) <small>(NOTE: This characteristic was not included in Dr. Babrauskas' proposal but is included here since it is part of the ATF training curriculum.)</small>

ATF - Jeremy Neagle, PE  
Arcing





ATF - Jeremy Neagle, PE  
arcing



## ATF – Jeremy Neagle PE

Resolidification Waves – The metal was molten and cooled quickly  
“freezing” the waves in the metal.

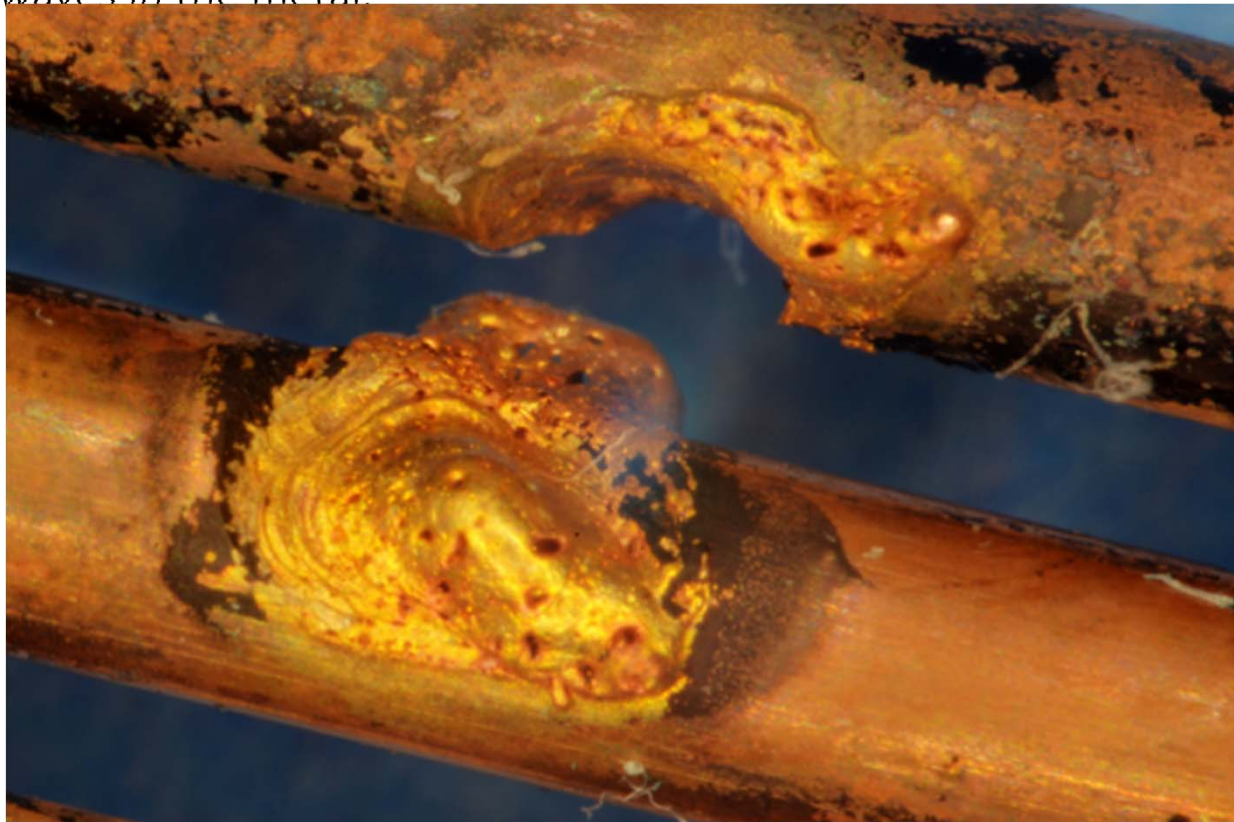

ATF – Jeremy Neagle, PE  
arcing

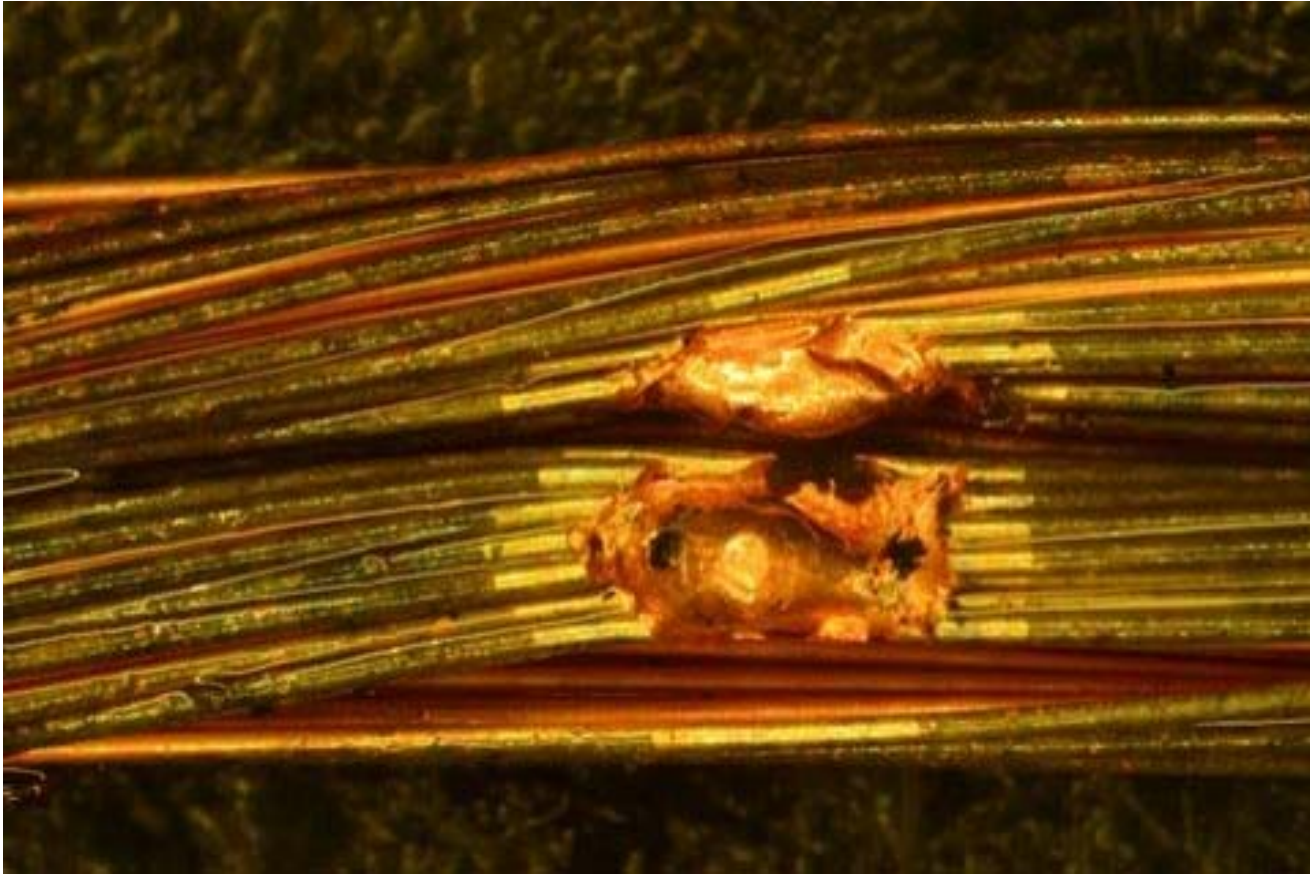

ATF - Jeremy Neagle PE  
Fire Melting





ATF Jeremy Neagle, PE  
Fire Melting

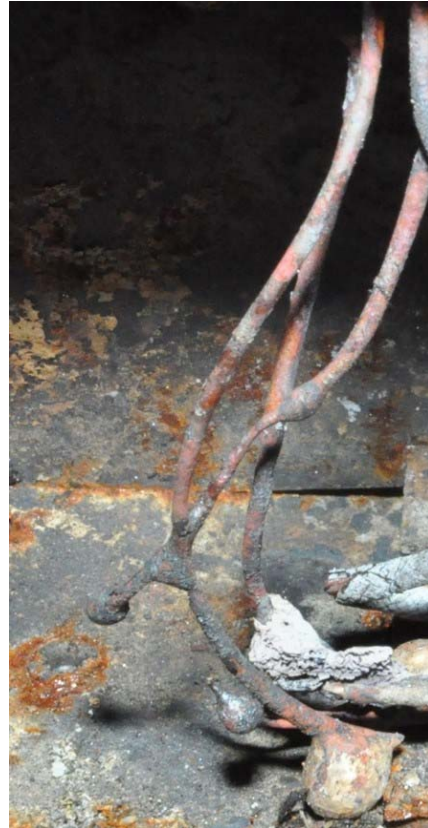

ATF – Jeremy Neagle, PE  
Fire Melting



- If electricity is on and there is a fire, the fire will consume the wire insulation and the conductors will come in contact with each other. If the wires are solid conductors, this usually causes the circuit breaker to trip.
- But where is the arc bead? It is somewhere in the middle of a wire run. Why would a wire fail in the middle of a run and cause a fire?
- Wires usually fail at the end points due to poor connections and resistive heating.

- Test Question?
- The usually failure points of a wire are at the terminal points where connections are made, and not in the middle of a wire run.
  - A) True
  - B) False

Ans.: A - True



# SO WHAT CAUSES ELECTRICAL FIRES?

Short Circuits ??

Overloads ??

Loose or Failed Connections??

Product Failure ??

Pinched Cords ??

Etc.

# MYTH: SHORT CIRCUITS CAUSE FIRES

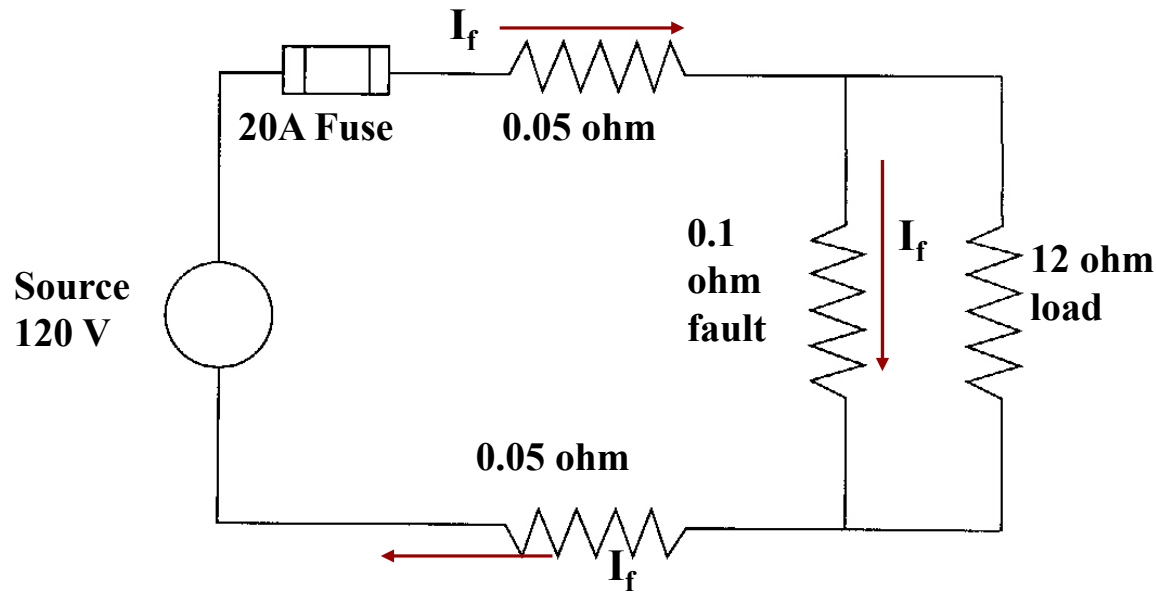

$$I_f = 120V / 0.2 \text{ ohm} = 600 \text{ Amps}$$

**At 600 amps the fuse blows (or circuit breaker trips) instantly. Even if a penny was placed in the fuse holder, the 60 amp main fuse would trip. Short circuits rarely cause fires. They are short duration events that cause overcurrent devices to operate.**

# MYTH – OVERLOADED CONDUCTORS CAUSE FIRES

The tables for wire sizing from the National Electrical Code are extremely conservative.

Insulation temperature rating

12 AWG wire

Rated for 30 amps

70-126

ARTICLE 310 -- CONDUCTORS FOR GENERAL WIRING

Table 310-16. Allowable Ampacities of Insulated Conductors Rated 0 through 2000 Volts, 60°C through 90°C (140°F through 194°F) Not More than Three Current-Carrying Conductors in Raceway, Cable, or Earth (Directly Buried), Based on Ambient Temperature of 30°C (86°F)

Size  AWG or kcmil	Temperature Rating of Conductor (See Table 310-13)						Size  AWG or kcmil
	60°C (140°F)		75°C (167°F)		90°C (194°F)		
	Types TW, UF	Types FEPW, RH, RHW, THHW, THW, THWN, XHHW, USE, ZW	Types TBS, SA, SIS, FEP, FEPB, MI, RHH, RHW- 2, THHN, THHW, THW-2, THWN- 2, USE-2, XHH, XHHW, XHHW- 2, ZW-2	Types TW, UF	Types RH, RHW, THHW, THW, THWN, XHHW, USE	Types TBS, SA, SIS, THHN, TBHW, THW-2, THWN-2, RHH, RHW-2, USE-2, XEB, XHHW, XHHW-2, ZW-2	
COPPER							
18	—	—	14	—	—	—	—
16	—	—	18	—	—	—	—
14*	20	20	25	—	—	—	—
12*	25	25	30	20	20	25	12*
10*	30	35	40	25	30	35	10*
8	40	50	55	30	40	45	8
6	55	65	75	40	50	60	6
4	70	85	95	55	65	75	4
3	85	100	110	65	75	85	3
2	95	115	130	75	90	100	2
1	110	130	150	85	100	115	1
ALUMINUM OR COPPER-CLAD ALUMINUM							
1/0	125	150	170	100	120	135	1/0
2/0	145	175	195	115	135	150	2/0
3/0	165	200	225	130	155	175	3/0
4/0	195	230	260	150	180	205	4/0
250	215	255	290	170	205	230	250
300	240	285	320	190	230	255	300
350	260	310	350	210	250	280	350
400	280	335	380	225	270	305	400
500	320	380	430	260	310	350	500
600	355	420	475	285	340	385	600
700	385	460	520	310	375	420	700
750	400	475	535	320	385	435	750
800	410	490	555	330	395	450	800
900	435	520	585	355	425	480	900
1000	455	545	615	375	445	500	1000
1250	495	590	665	405	485	545	1250
1500	520	625	705	435	520	585	1500
1750	545	650	735	455	545	615	1750
2000	560	665	750	470	560	630	2000

CORRECTION FACTORS

Ambient Temp. (°C)	For ambient temperatures other than 30°C (86°F), multiply the allowable ampacities shown above by the appropriate factor shown below.						Ambient Temp. (°F)
21-25	1.08	1.05	1.04	1.08	1.05	1.04	70-77
26-30	1.00	1.00	1.00	1.00	1.00	1.00	78-86
31-35	0.91	0.94	0.96	0.91	0.94	0.96	87-89
36-40	0.82	0.88	0.91	0.82	0.88	0.91	96-104
41-45	0.71	0.82	0.87	0.71	0.82	0.87	105-113
46-50	0.58	0.75	0.82	0.58	0.75	0.82	114-122
51-55	0.41	0.67	0.76	0.41	0.67	0.76	123-131
56-60	—	0.58	0.71	—	0.58	0.71	132-140
61-70	—	0.33	0.58	—	0.33	0.58	141-158
71-80	—	—	0.41	—	—	0.41	159-176

\*See Section 240.3.

A 12AWG wire will not even begin to smoke until it is carrying 100 amps. However, you cannot connect 100 Amps to a properly protected branch circuit wired with 12AWG. The breaker or fuse will trip long before the wire burns.

Overcurrent damage to a wire occurs along the entire length from the panelboard to the load. If the overcurrent protective device is incorrectly sized, or fails to operate, a fire can result from an overloaded conductor.

# Poor Connections - Resistive Heating

- NFPA 921 (2014) – Section 9.10.4 – Overheating Connections:  
Connection points are the most likely place for overheating to occur on a circuit. The most likely cause of the overheating will be a loose connection or the presence of resistive oxides at the point of the connection.



## Resistive Heating

- Begins with a loose connection having a larger contact resistance.
- The increased contact resistance causes resistive heating at the connection.
- Copper Oxide (Cupric oxide –  $\text{CuO}$ ) will form as the heated copper reacts with oxygen in the air.  $\text{CuO}$  is typically Black in color.
- Copper Oxide being semi-conductive will further increase the resistance.
- The cycle continues until a glowing connection and/or failure occurs.
- Above  $1,600^{\circ}\text{F}$ , an oxide of  $\text{Cu}_2\text{O}$  forms which is typically a red-orange color.

## Movement of Glow Spot: Welding of Conductor



T = 0 hours



T = 2.7 hours



T = 5.5 hours

# Overheating Connections

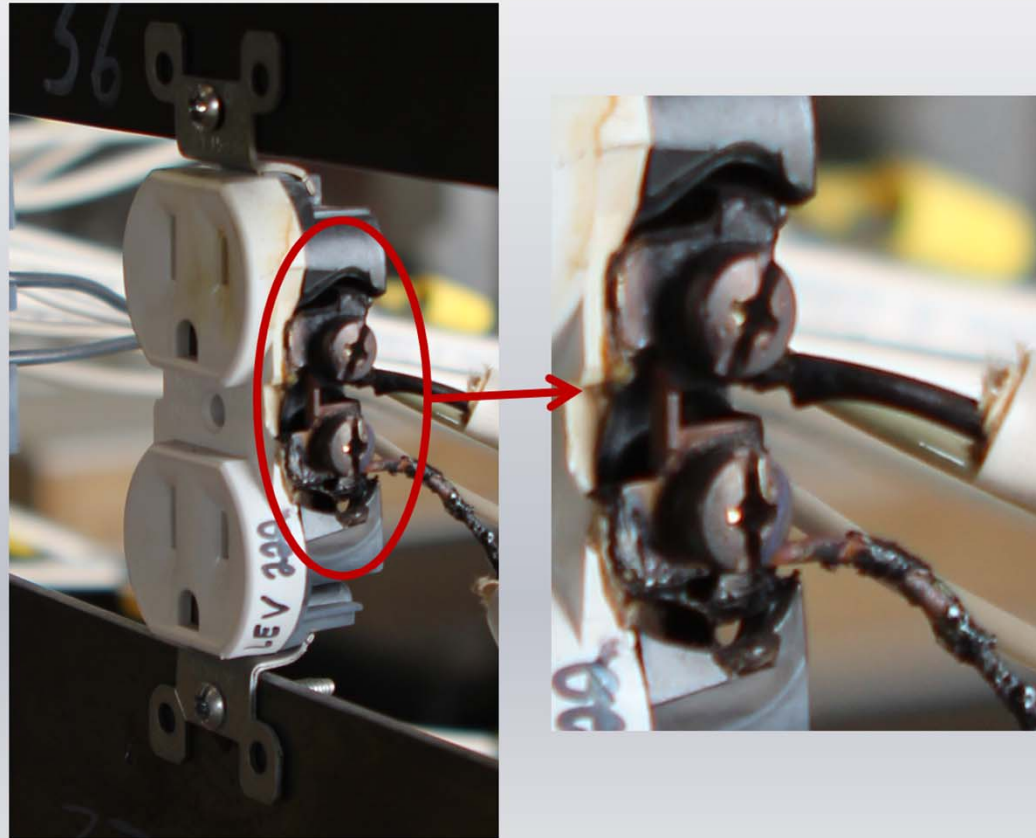

Melting of plastic near screw terminals.

# Overheating Connections

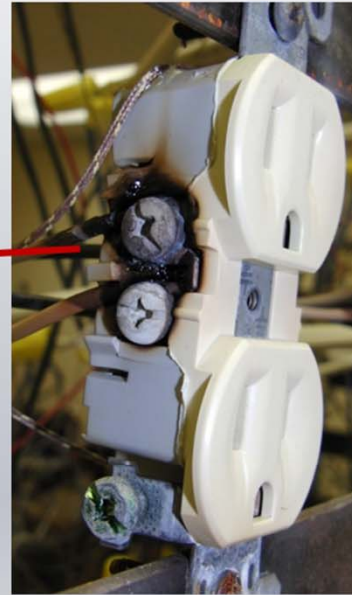

Discoloration/charring of plastic, loss of plating on screw, black oxidation of copper conductor.



# Overheating Connections

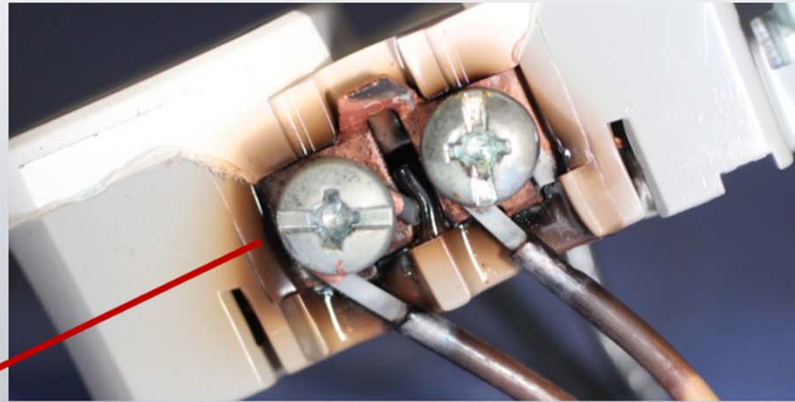

Discoloration/charring of plastic, white corrosion of copper conductor, and dezincification of brass contacts.

# Overheating Connections

**Polypropylene**



Melting, running and dripping

**PVC**

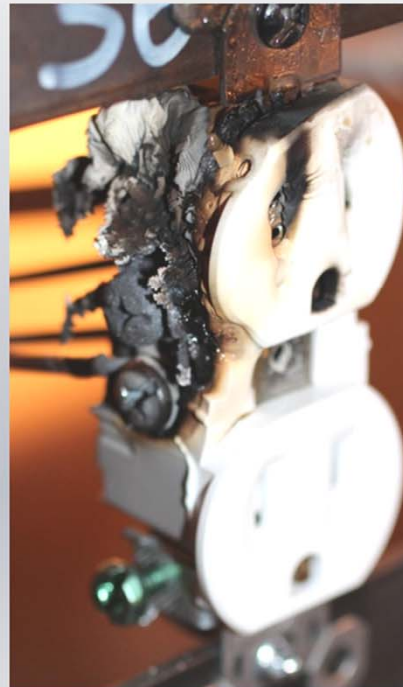

Softening, deforming, and charring

**Phenolic**

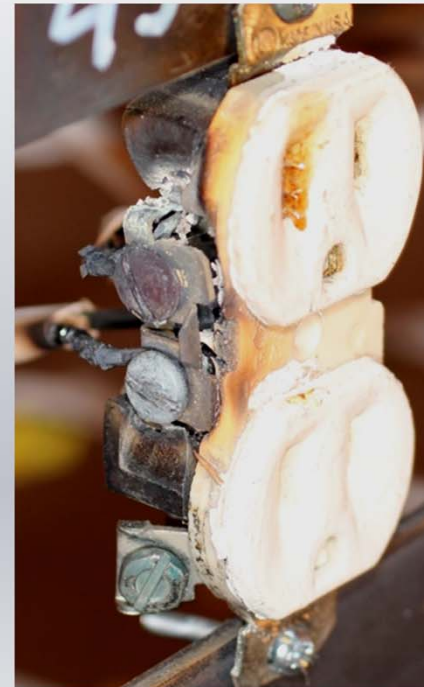

Cracking and localized crumbling

## Evidence of Glowing Connections



Welded Conductor  
w/Curved Striations



Severed Conductor  
(Welded w/Curved  
Striations)



Enlarged Screw  
Head

# Overheating Connections







0828

MADE IN CHINA  
GENERAL ELECTRIC CORPORATION  
MODEL NO. 722122  
MAXIMUM CURRENT  
RATED FOR USE  
SEE INSTRUCTION MANUAL

# Fires Caused By Lamp Holders

- Typically result of poor connection to lamps
- Improper seating of the lamp
- Improper spacing of lamp holders
- Improper installation of lamp holders
- More common with higher current lamps
- Generally occurs with Instant Start circuits
- Ballast is designed to maintain an arc and it will!

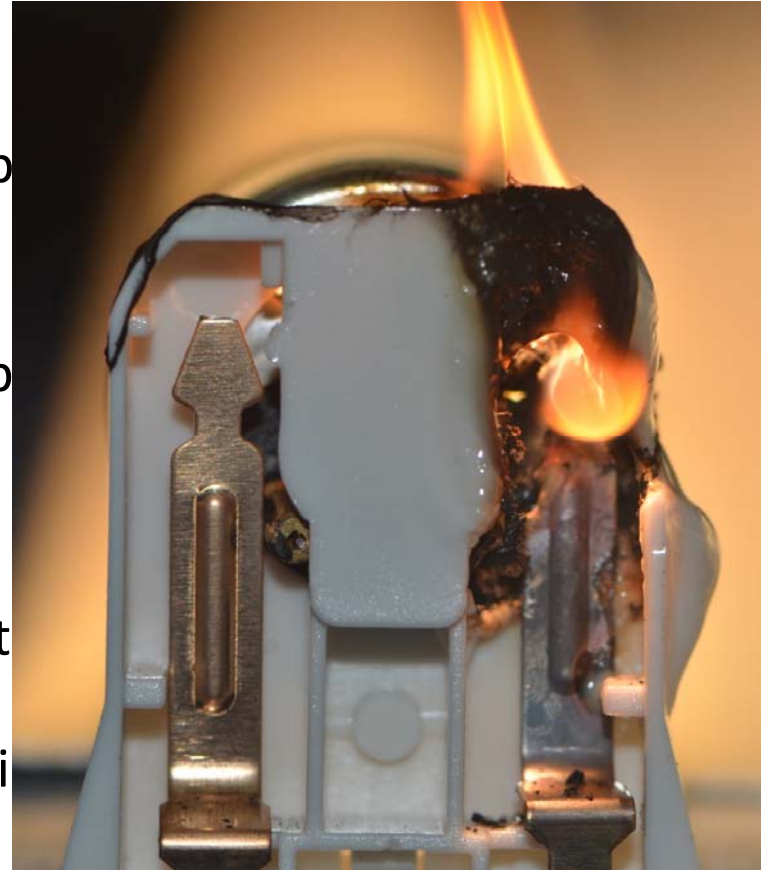

Arcing Damage





# LOOSE OR FAILED CONNECTIONS

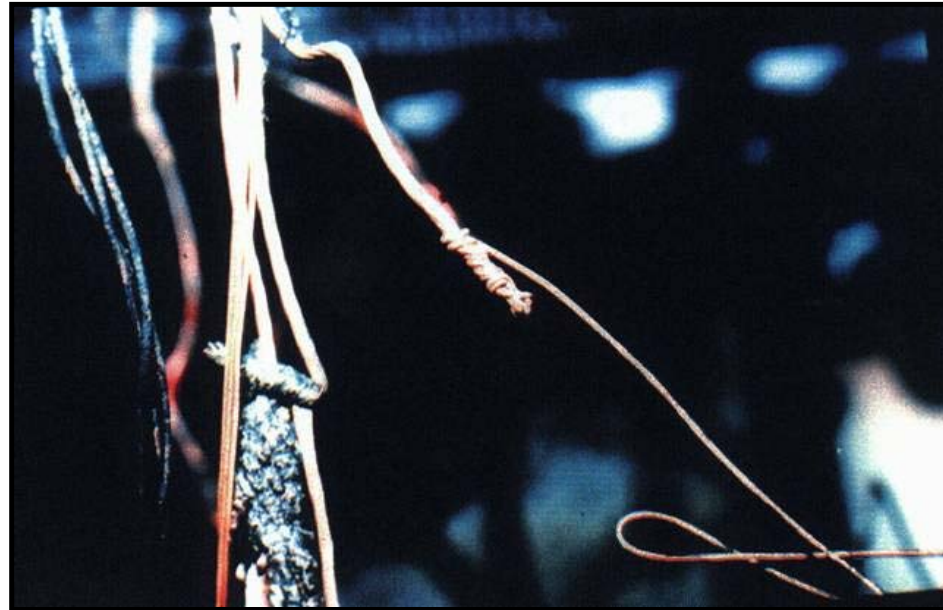

**A splice requires electrical continuity. It also requires mechanical security. This requires the use of proper terminals or connectors. Wire nuts are one way to maintain electrical contact and mechanical integrity. Duct tape is NOT.**



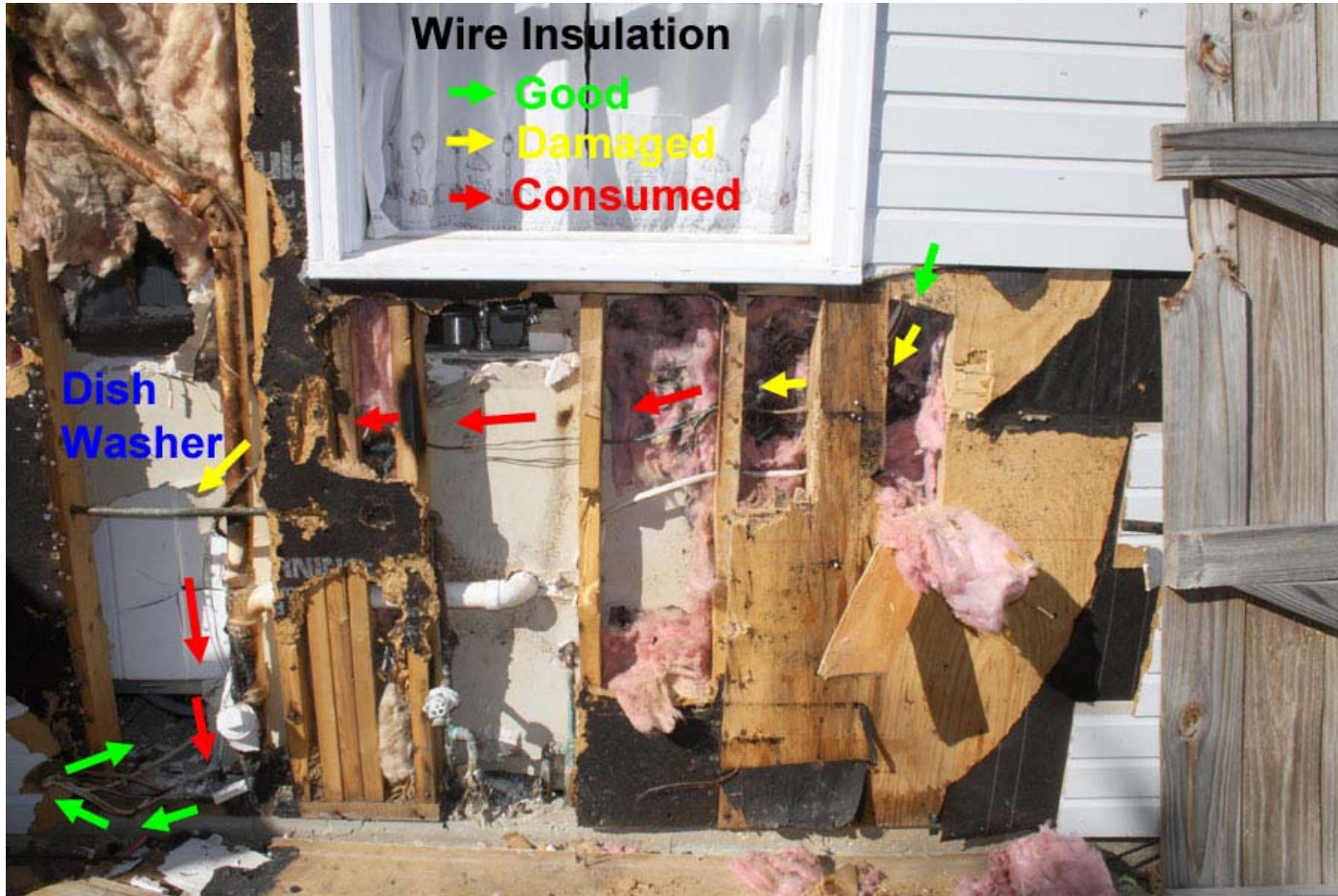

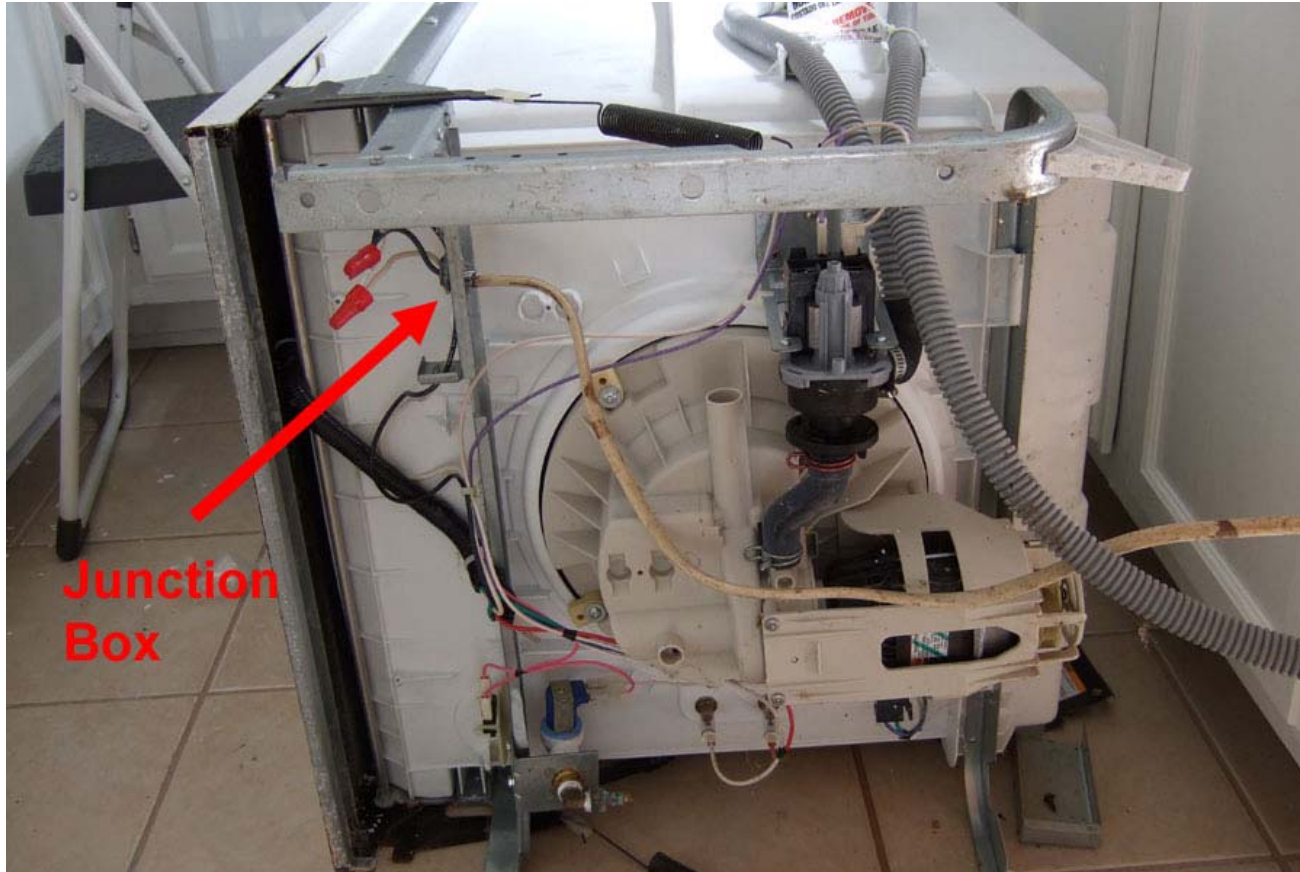

No Romex Connector, and Knockout Hole  
Too Small for Number and Size of Cable.

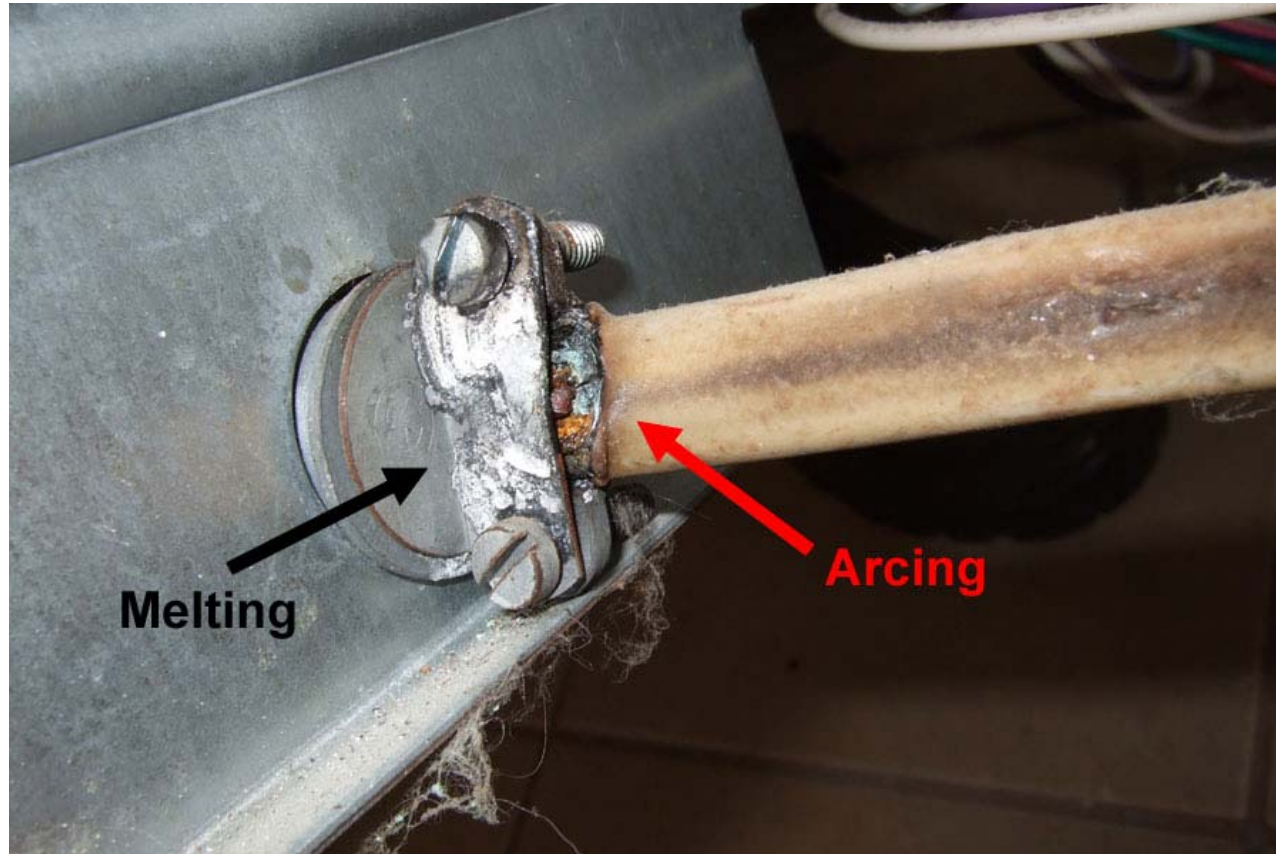

Over Tightened Romex Cable Clamp.



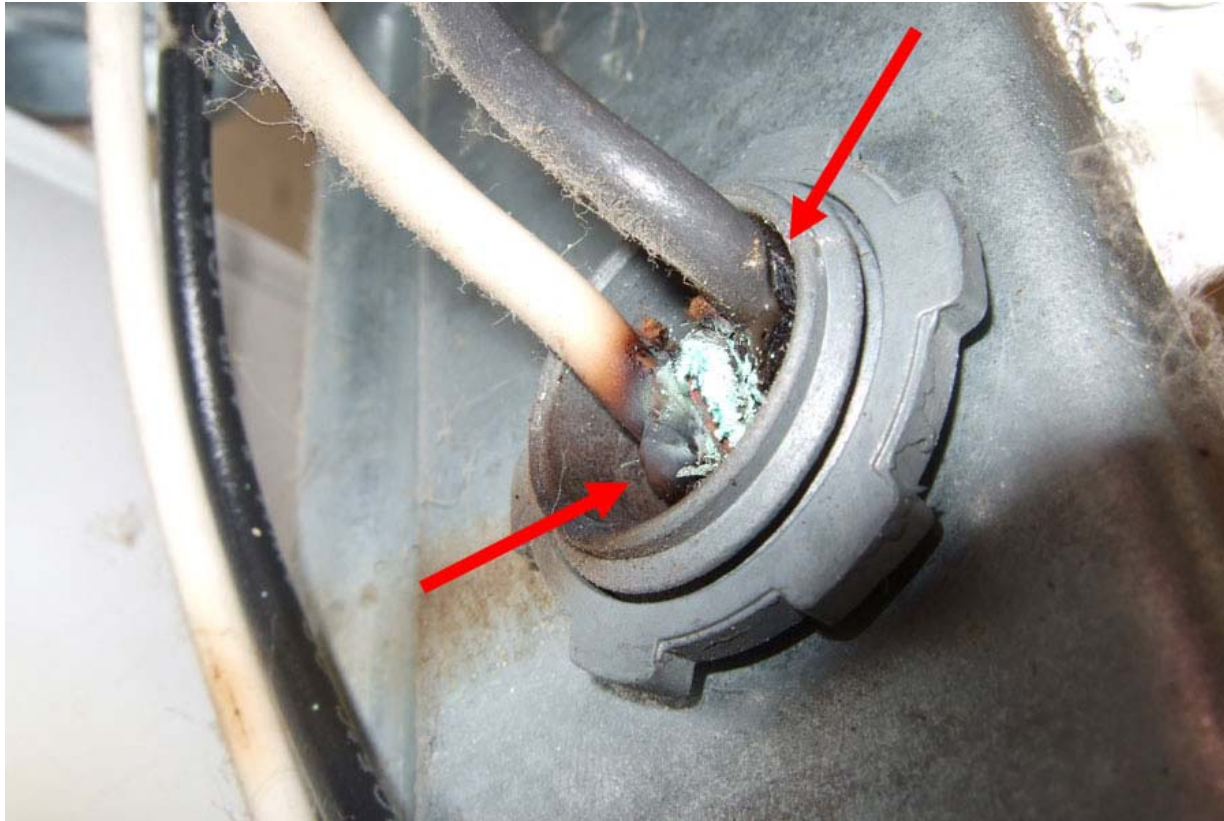

Damaged Wire Insulation at Front of Clamp.



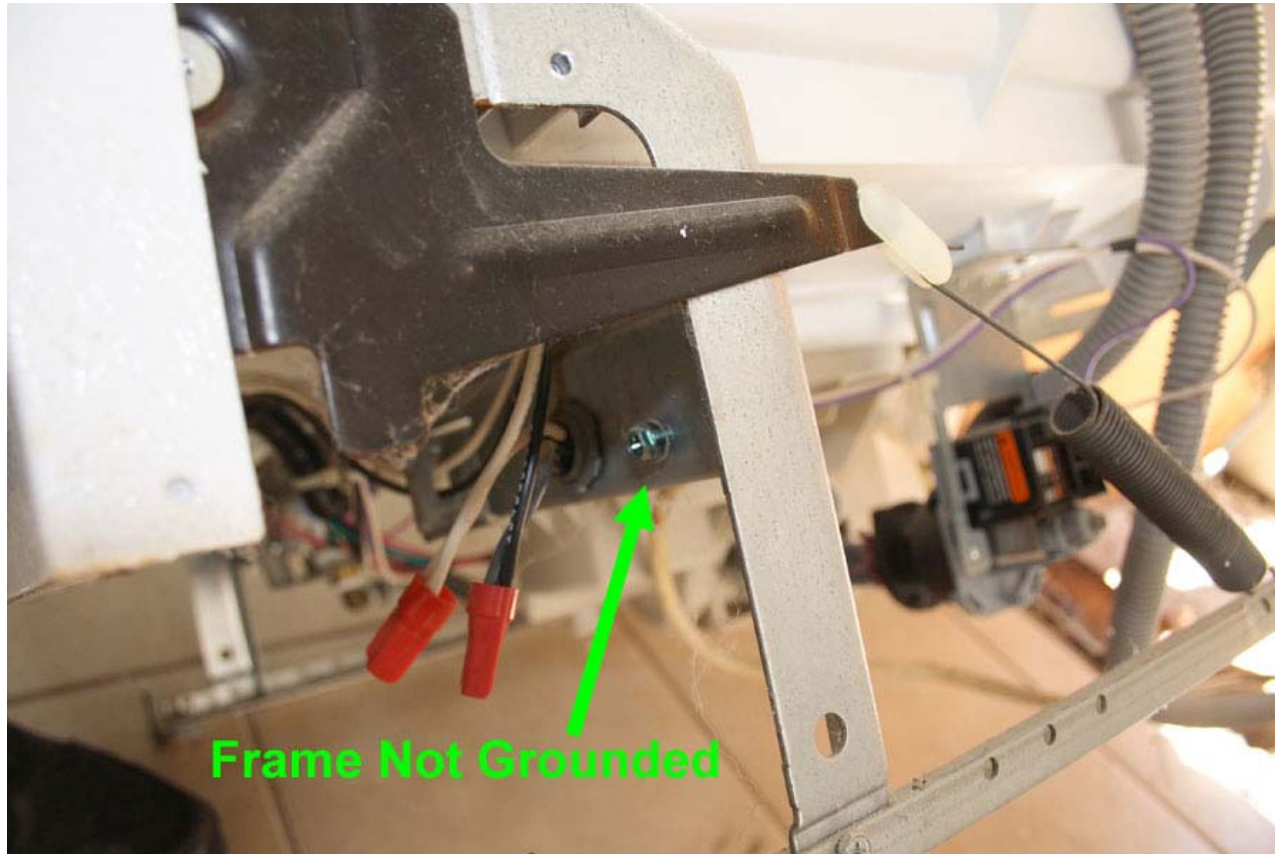

Safety Grounding Conductor Not Connected.

- I have been investigating fires for over 20 years, and I have never had a case where the fire started because a branch circuit was overload.
- There is no reason for a wire to fail in the middle of a run unless the wire insulation is damaged. The wire insulation can be damaged by over tightened staples and/or rodents.

# Product Failures



# **Hoverboard Fire Demonstration**



# Re-locatable power tap

Short Circuits



Surge Protection Failure



Damaged Wiring



Overloaded / Abused



# Re-locatable power tap



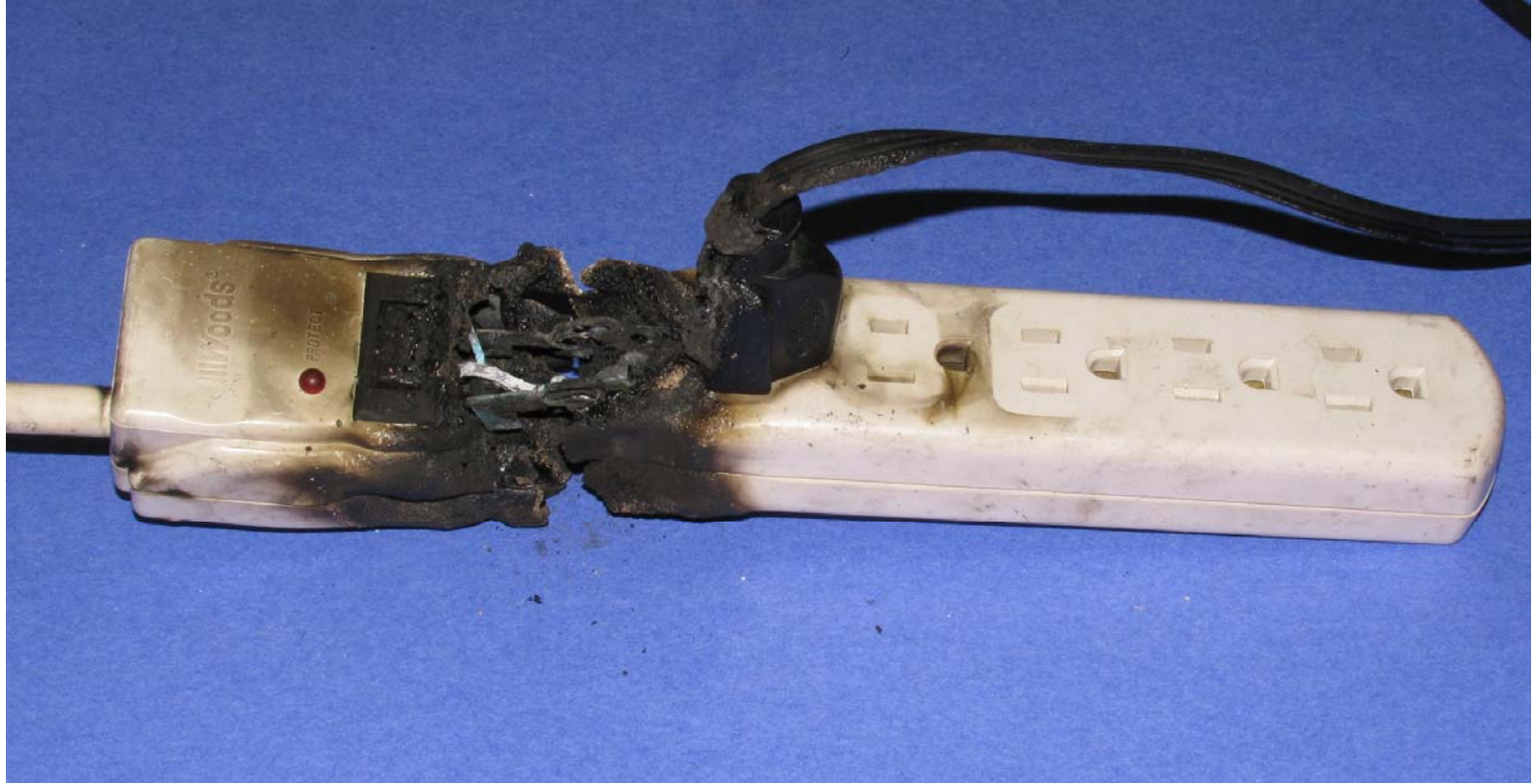



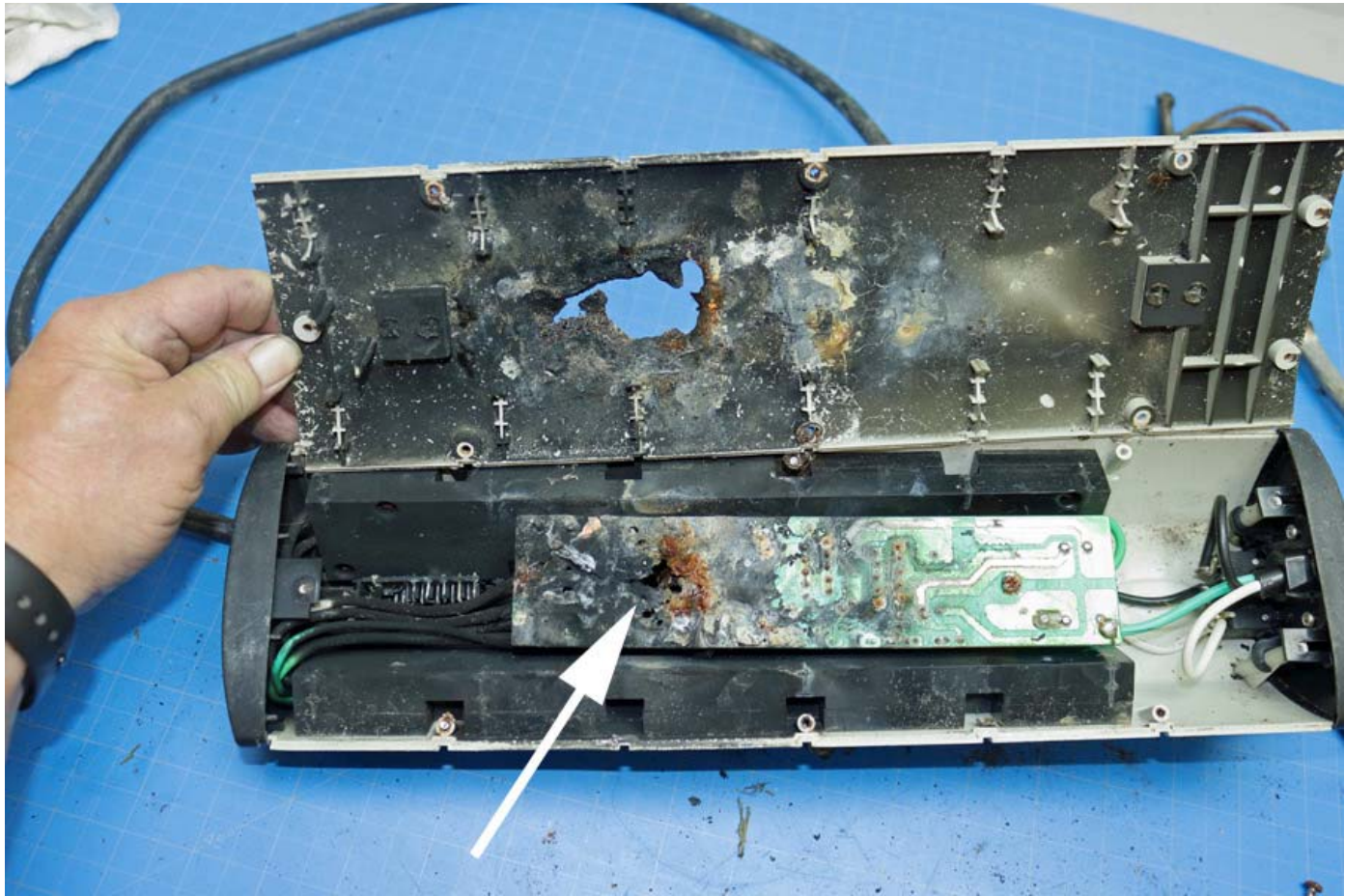





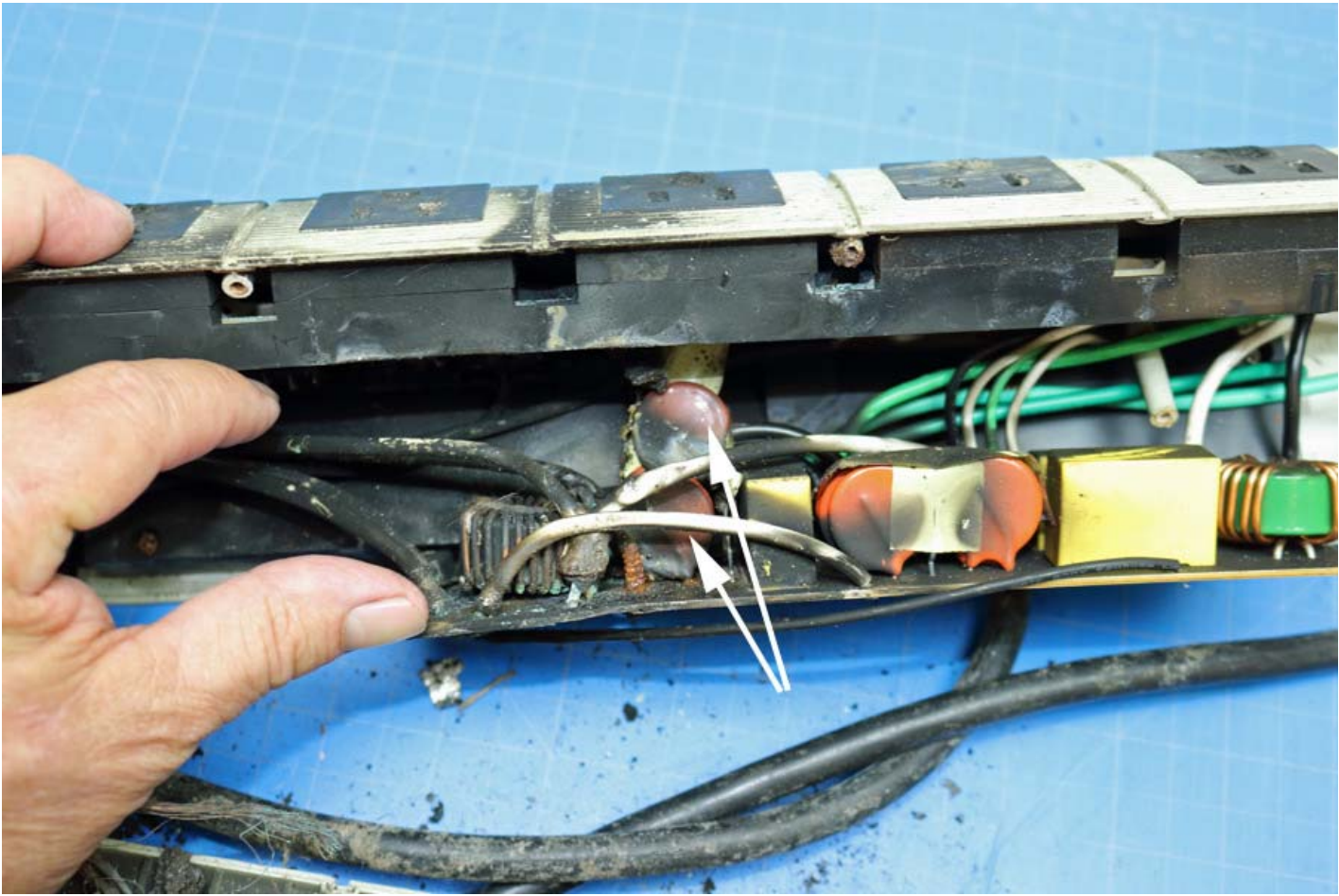

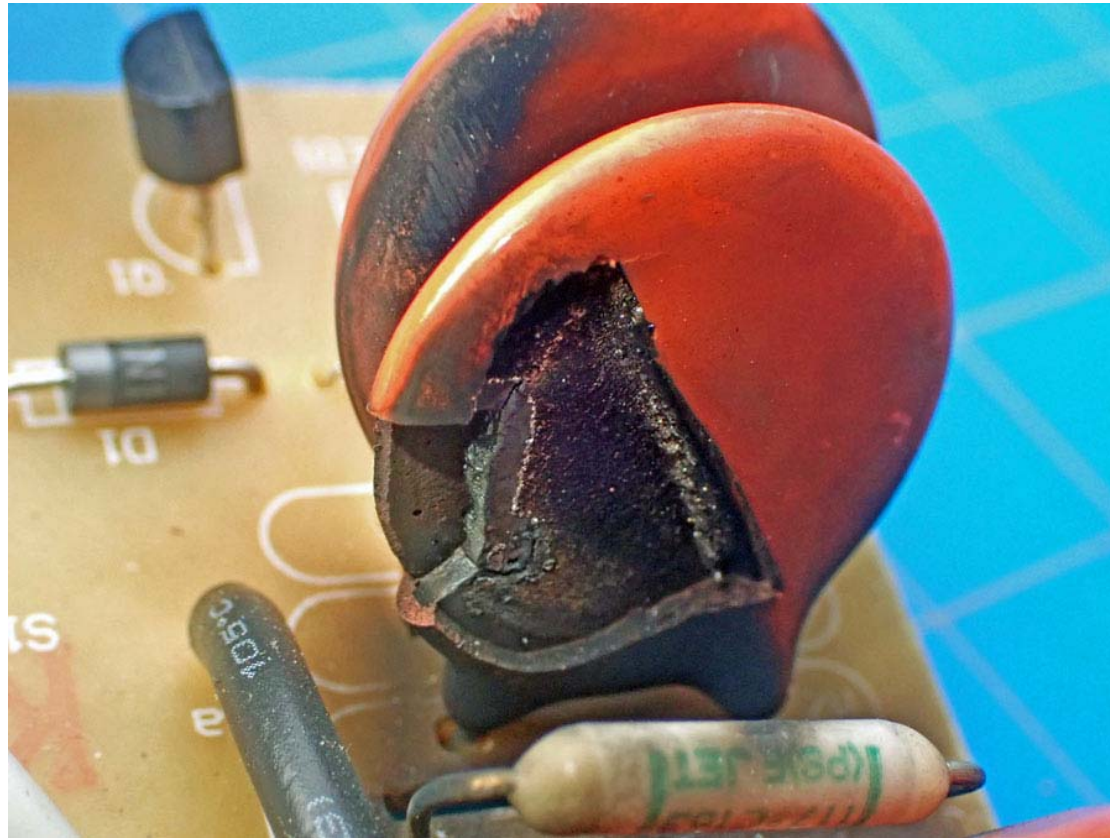

# Animal Problems



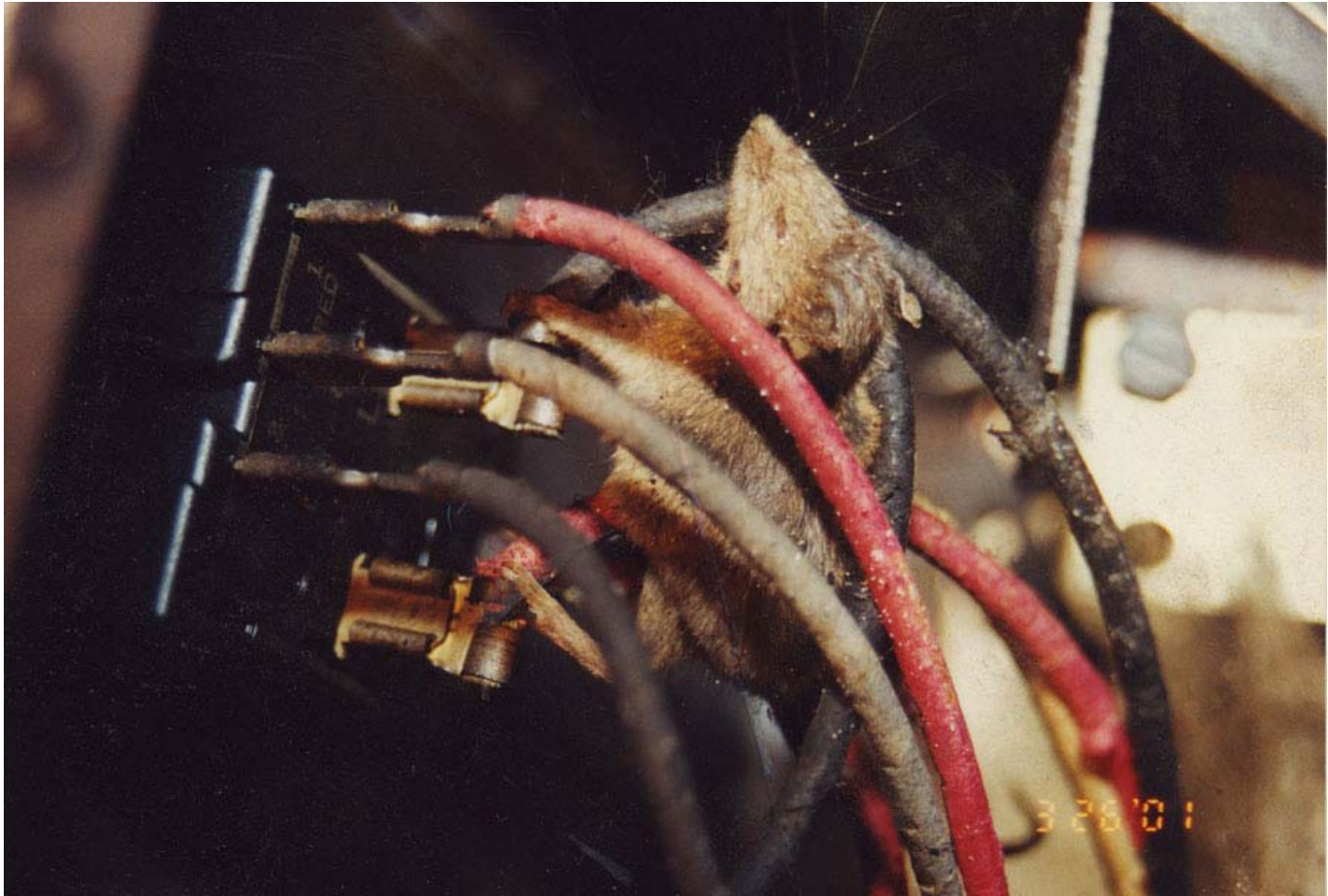

# Animals







# QUESTIONS?





# TPI Heater Thermostat

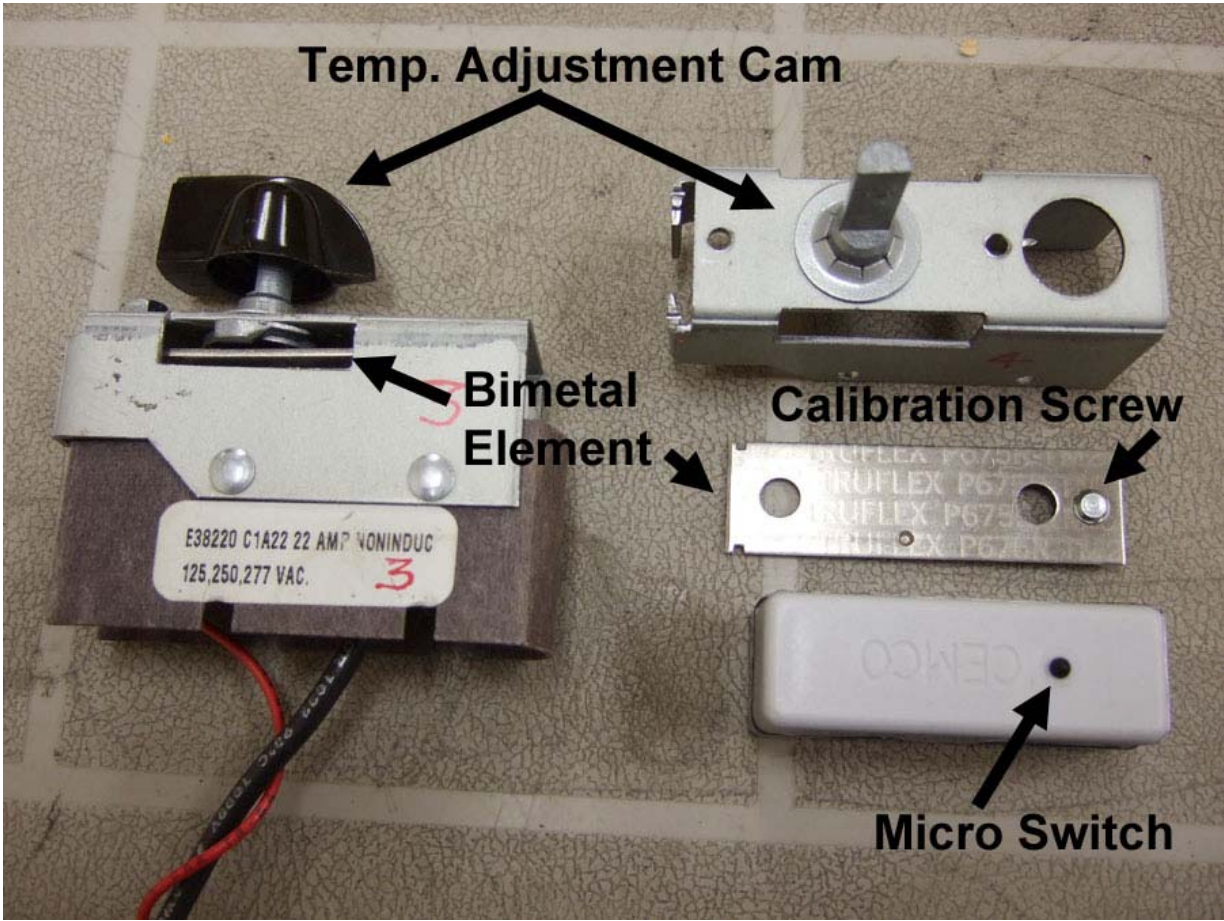

# Clothing Iron Thermostat

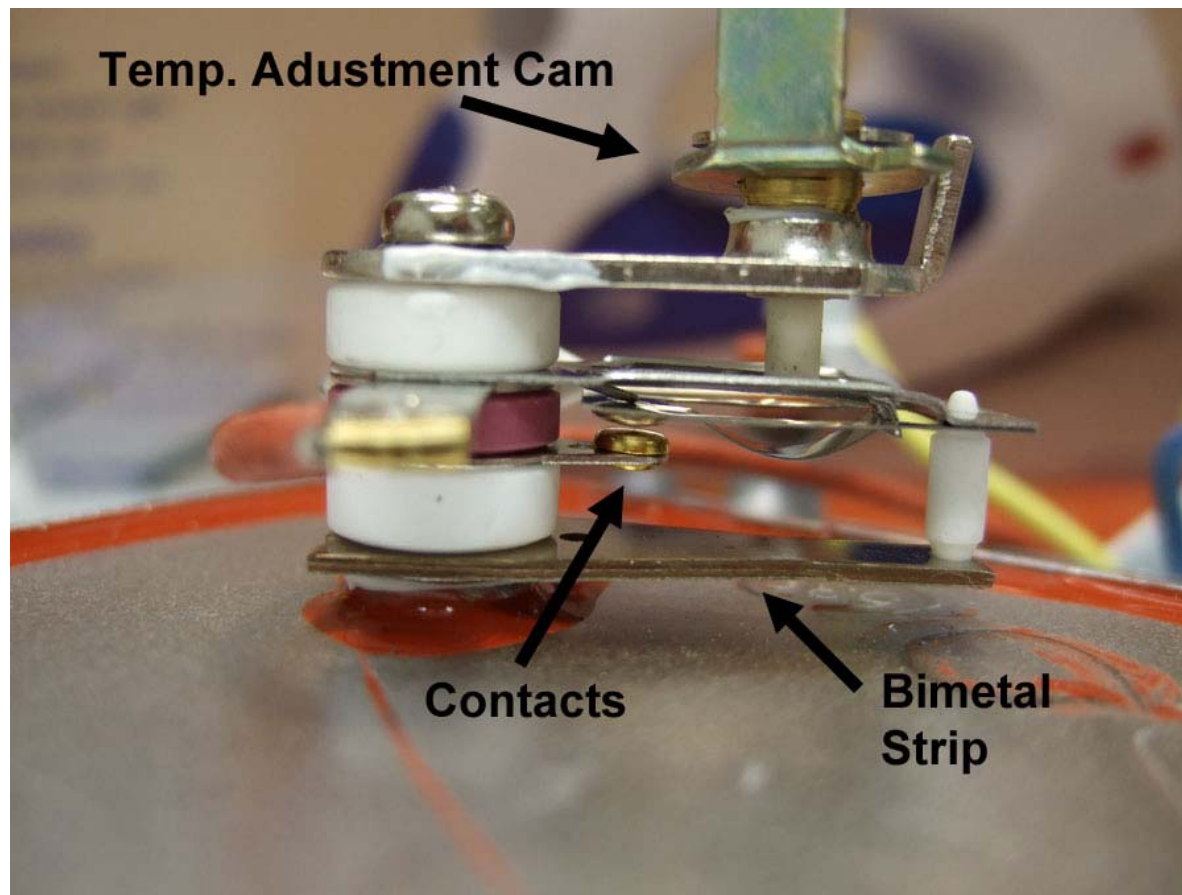

# Toaster Oven

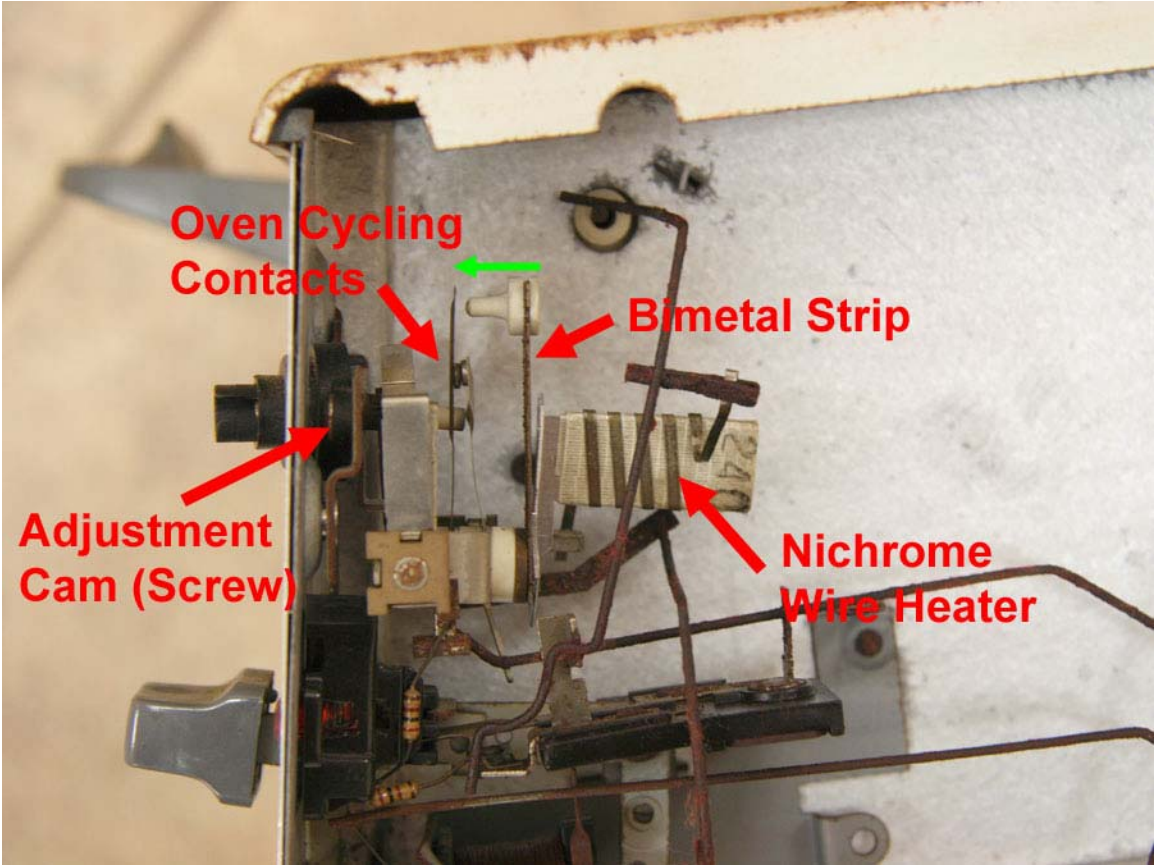

# HVAC Thermostat

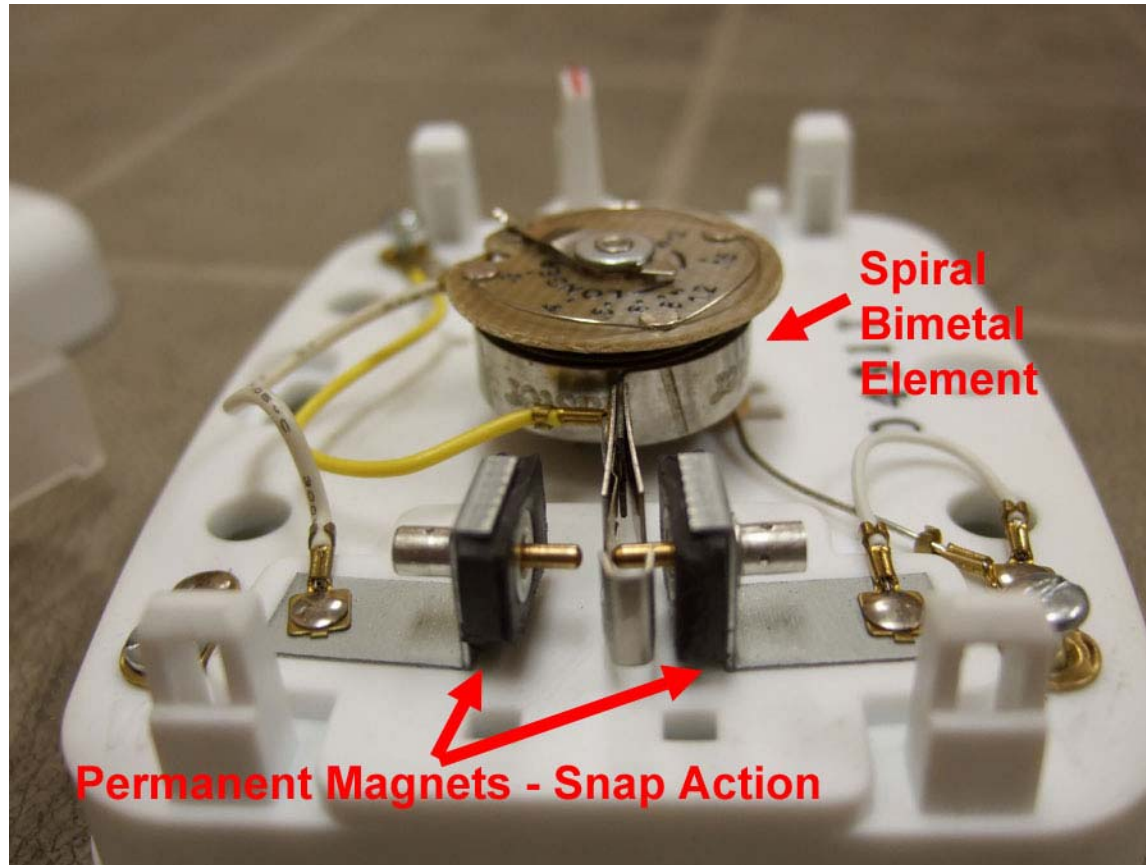



# Cooktop Control Switch

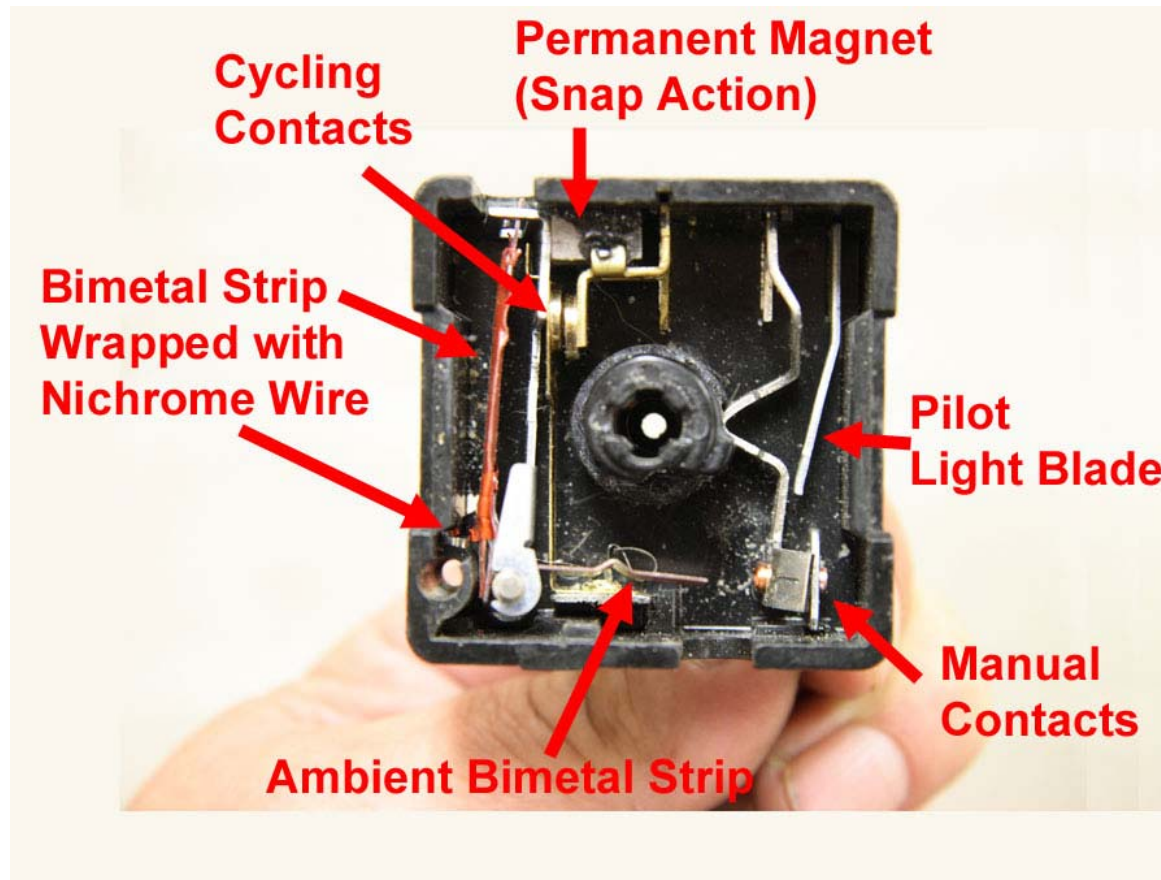

# Dryer Motor

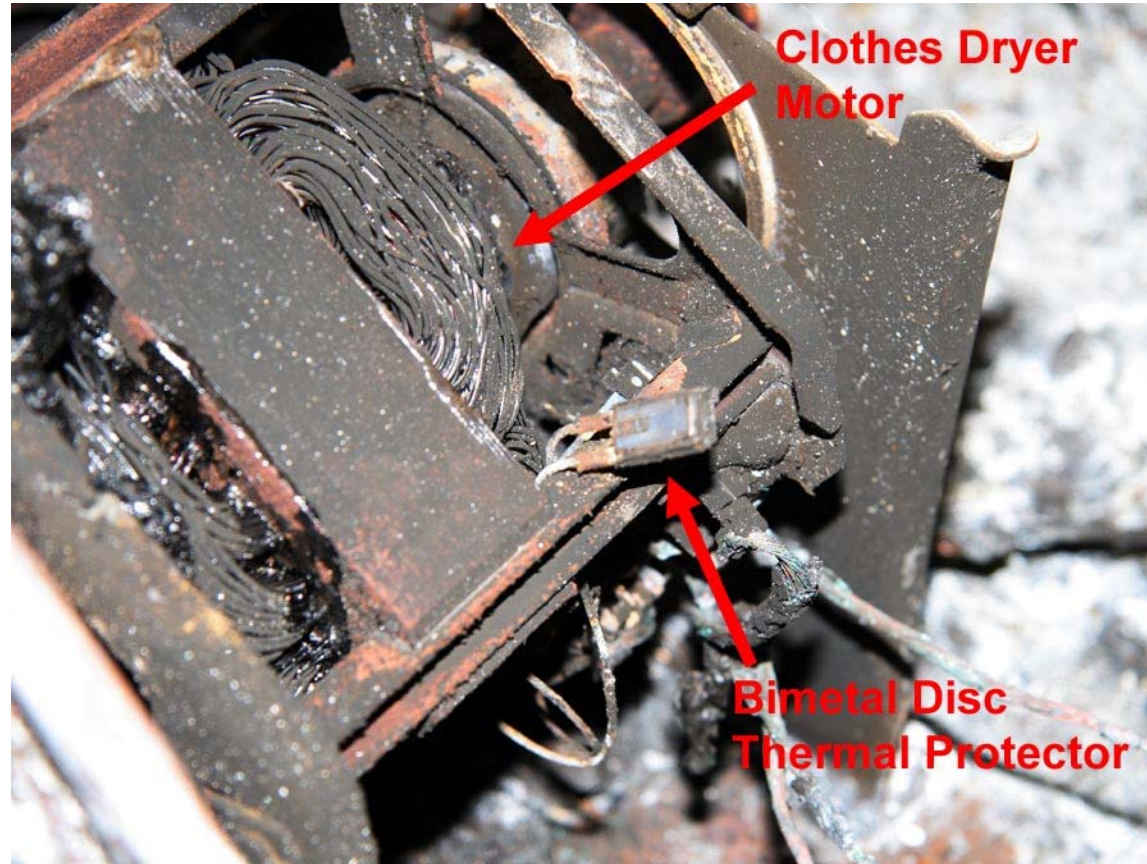

# Air Conditioning Compressor





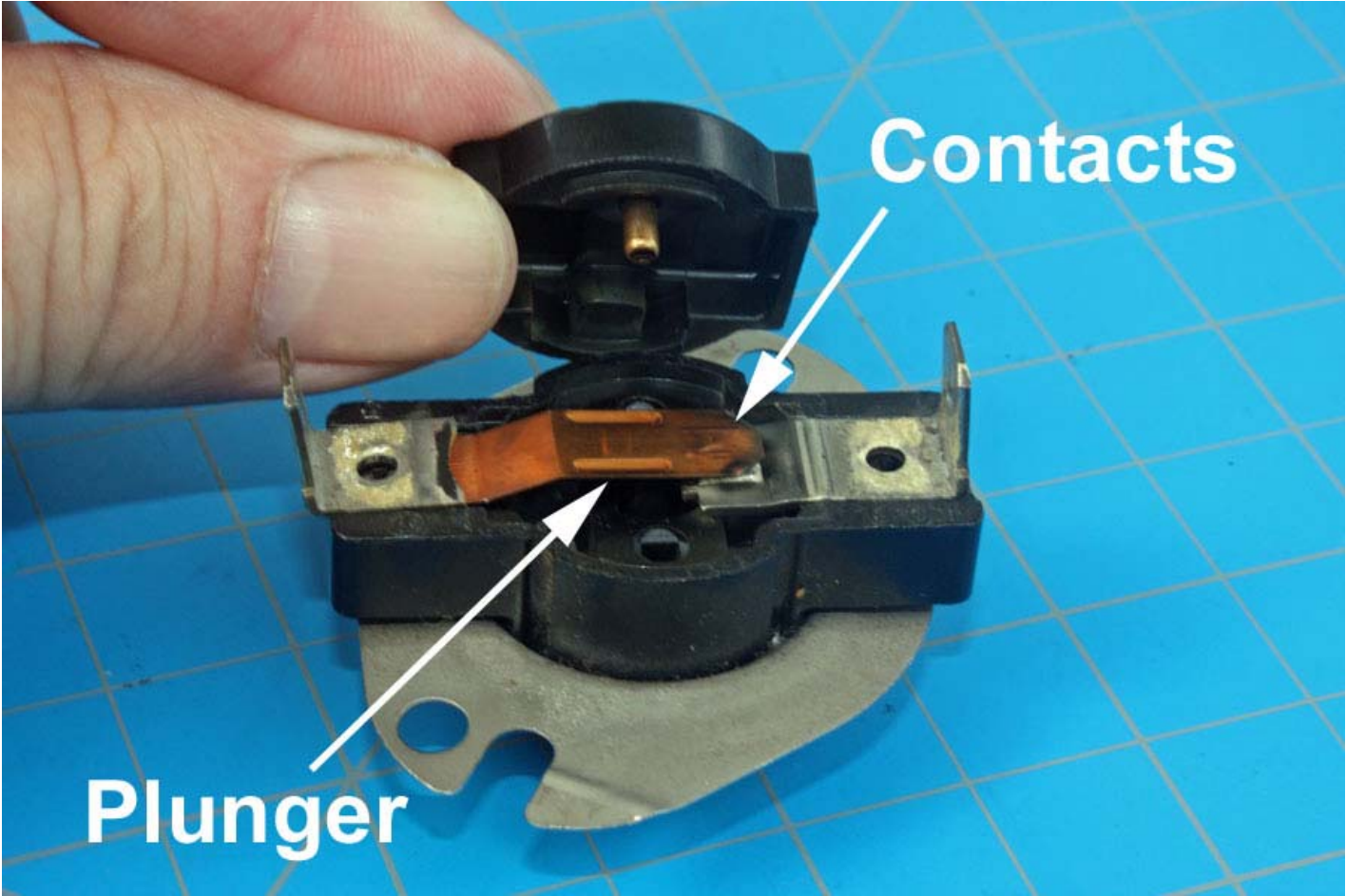

**Contacts**

**Plunger**



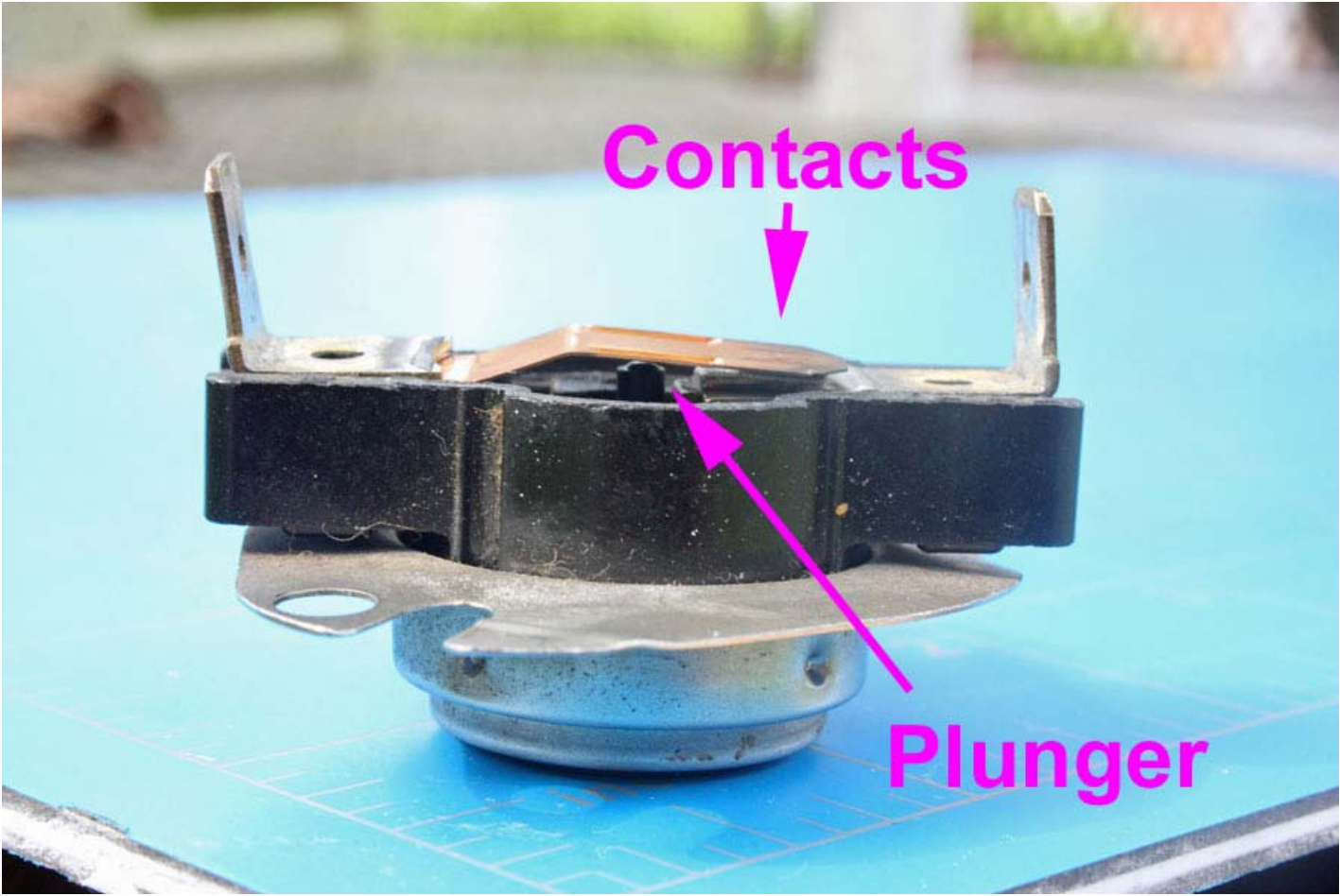

**Contacts**



**Plunger**



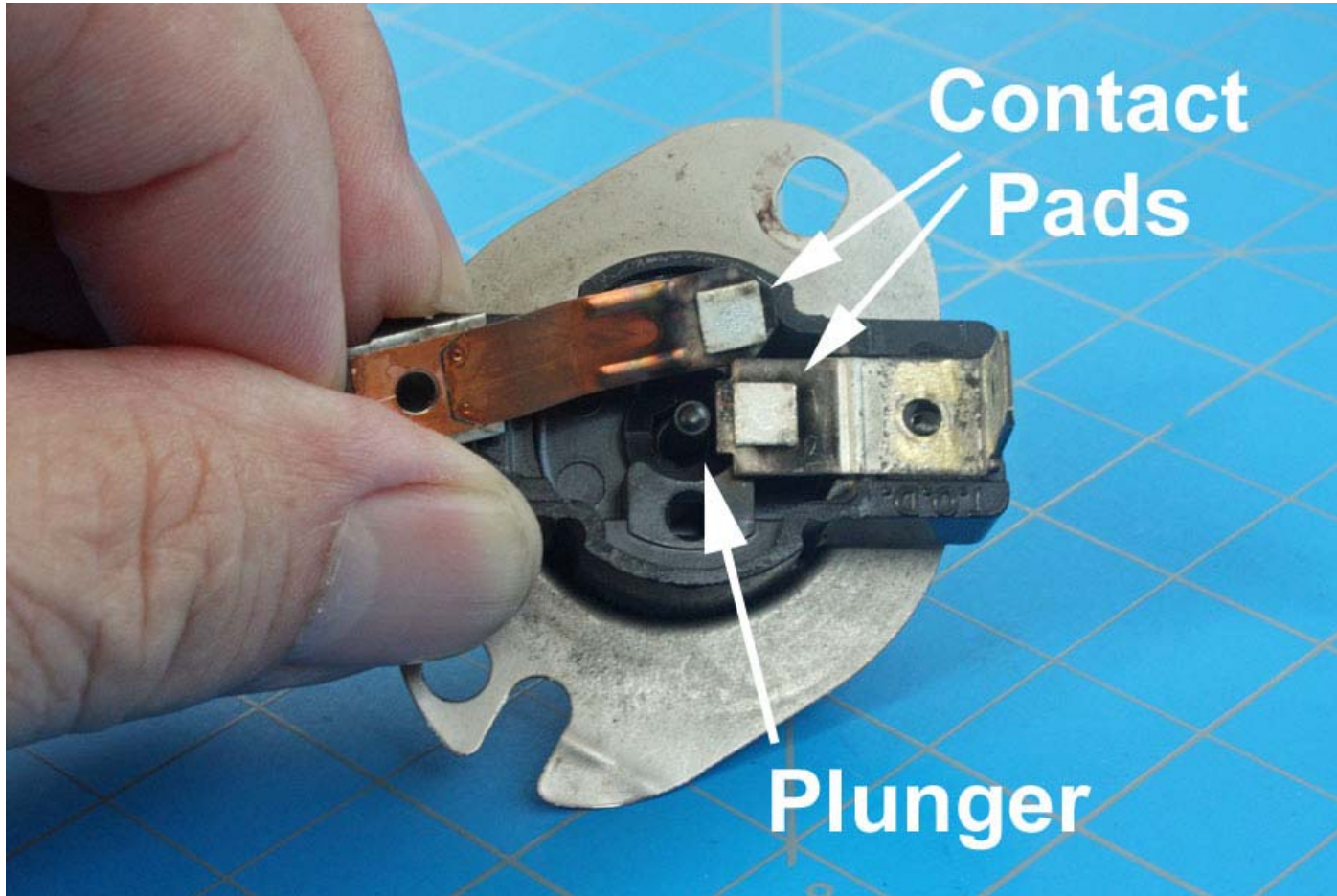

**Bimetal  
Disc**

**Plunger**

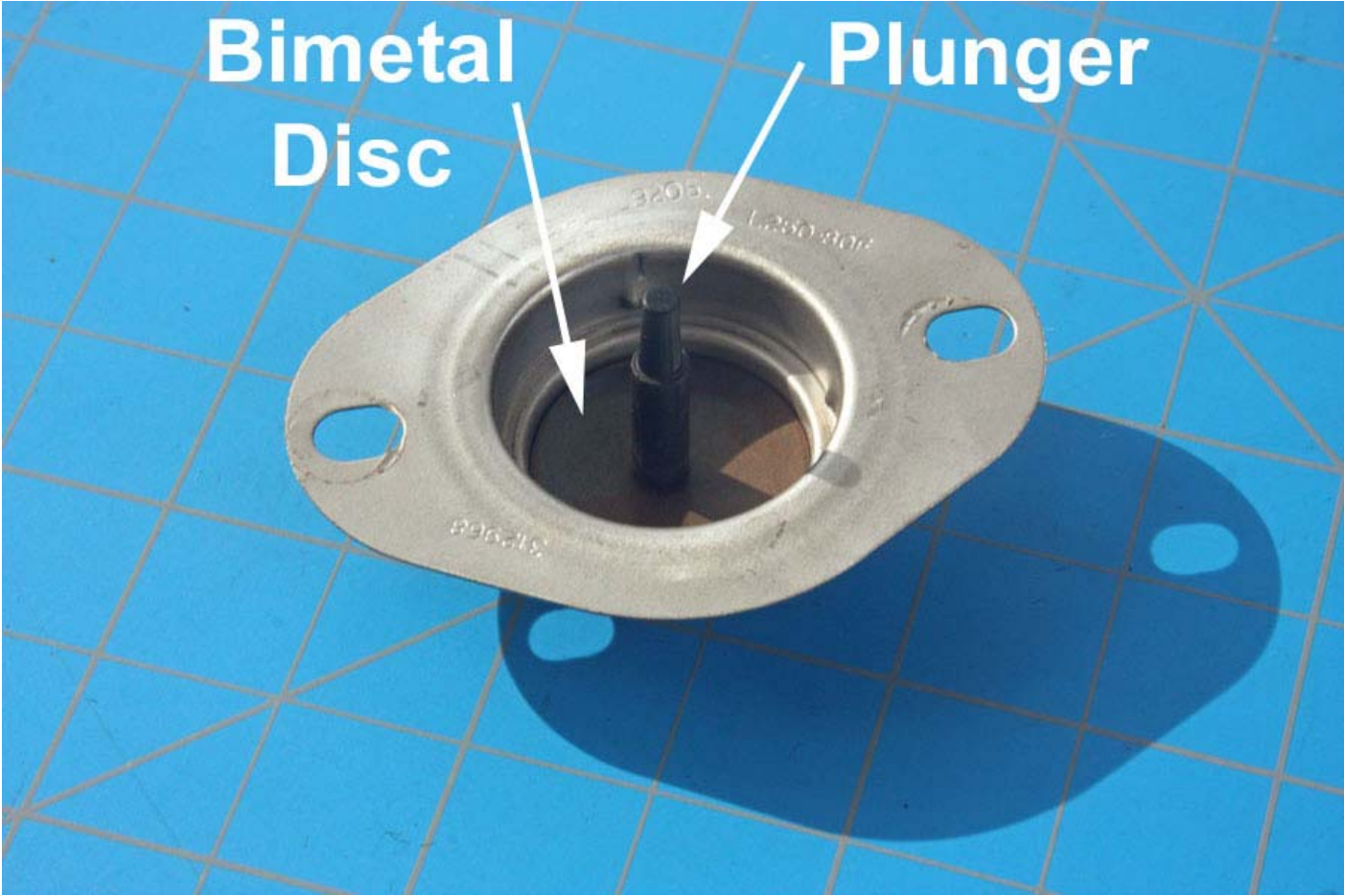



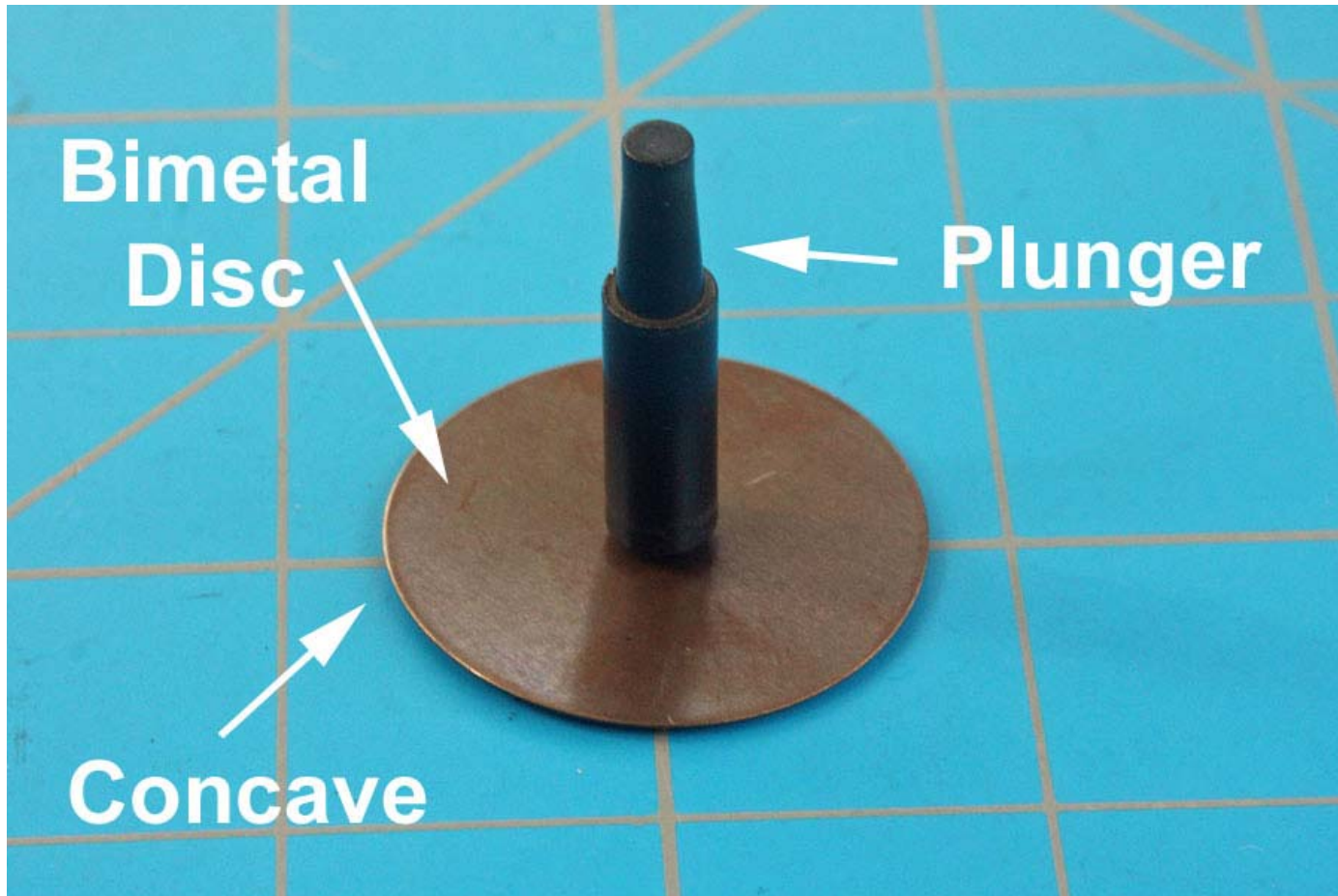

**Bimetal  
Disc**

**Plunger**

**Concave**



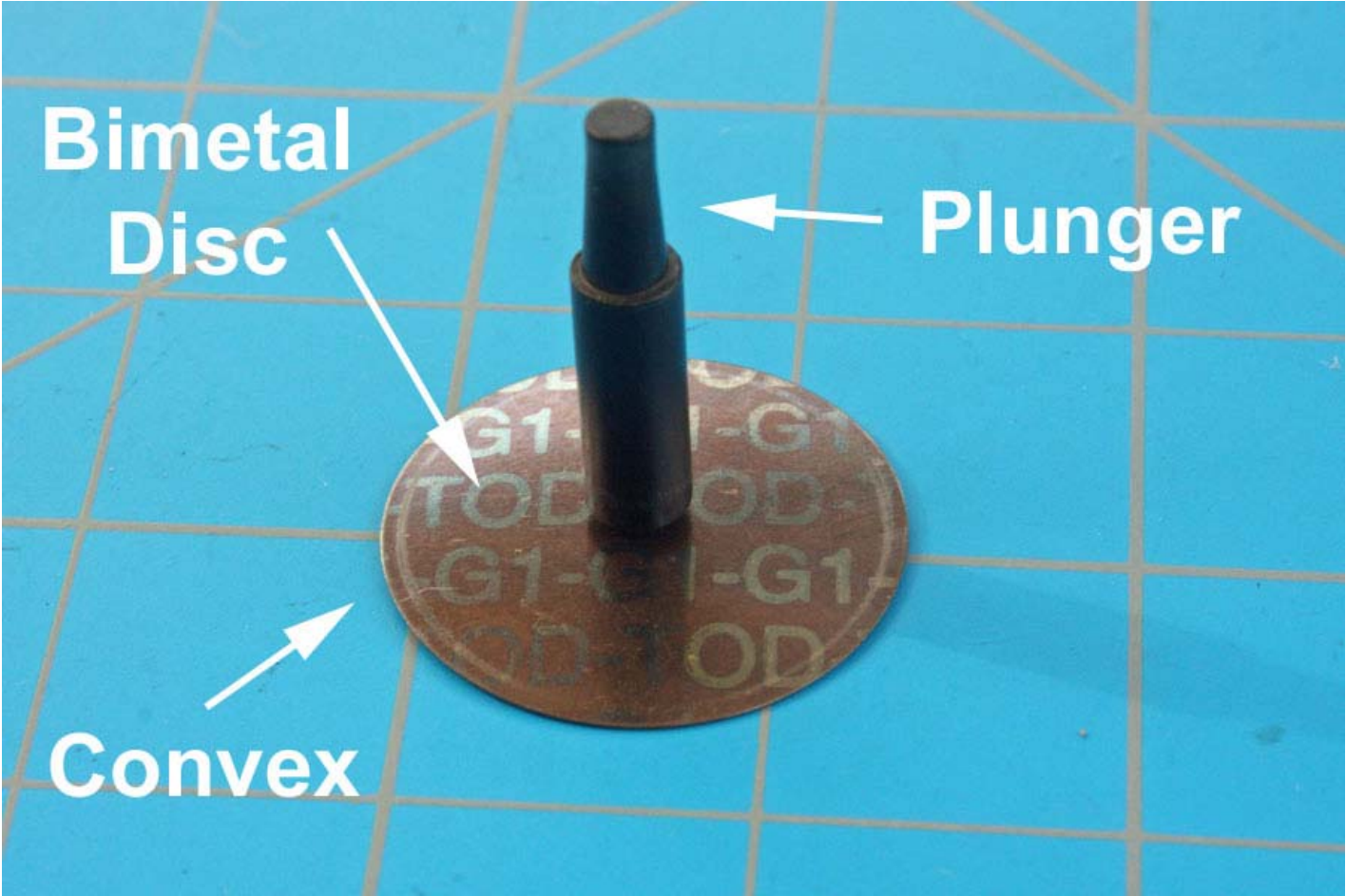

**Bimetal  
Disc**

**Plunger**

**Convex**

# Klixon 7AM Series

2012  
Week  
04

Temp Code: 029  
Opens at 110°C (230°F)

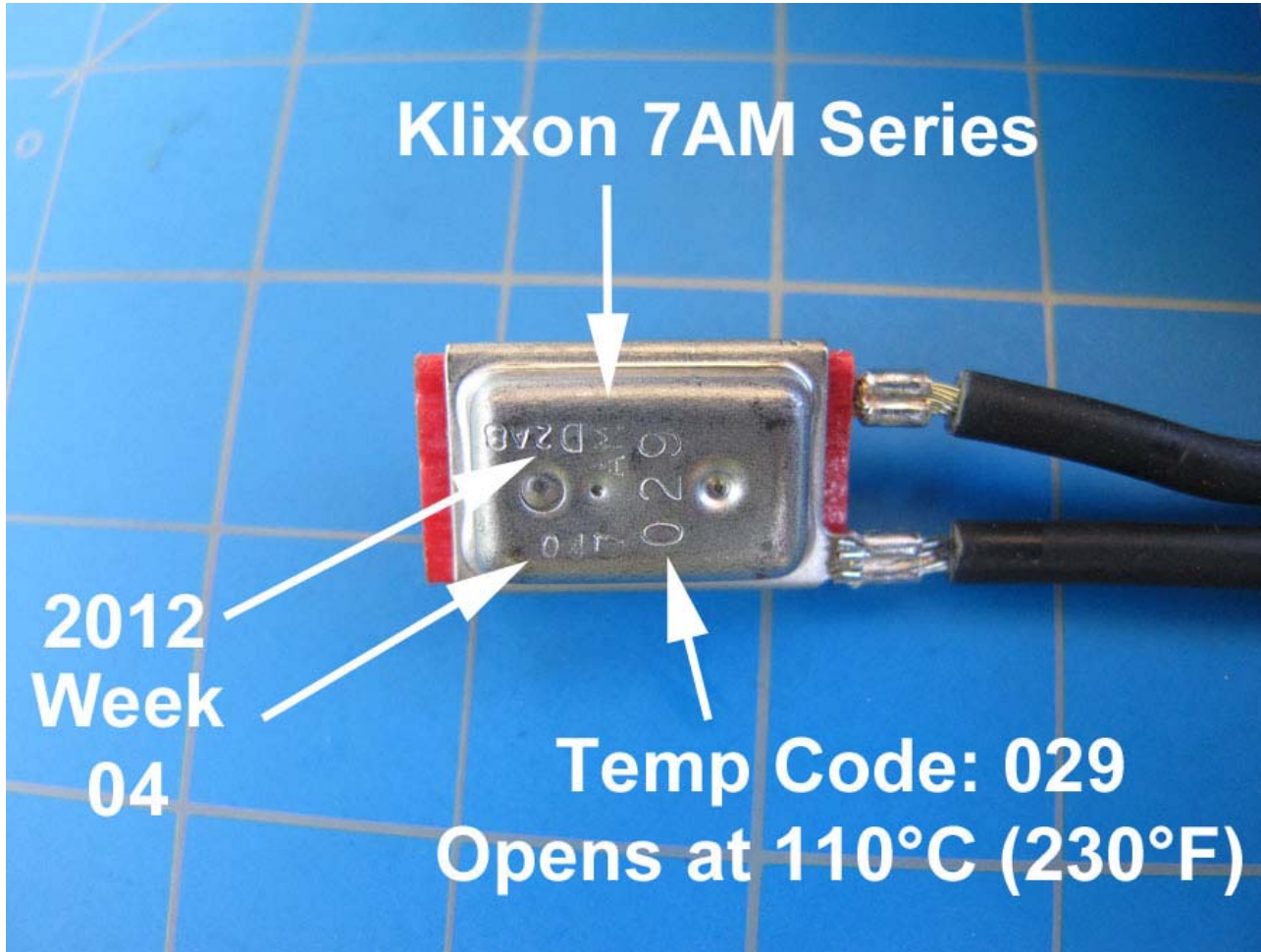

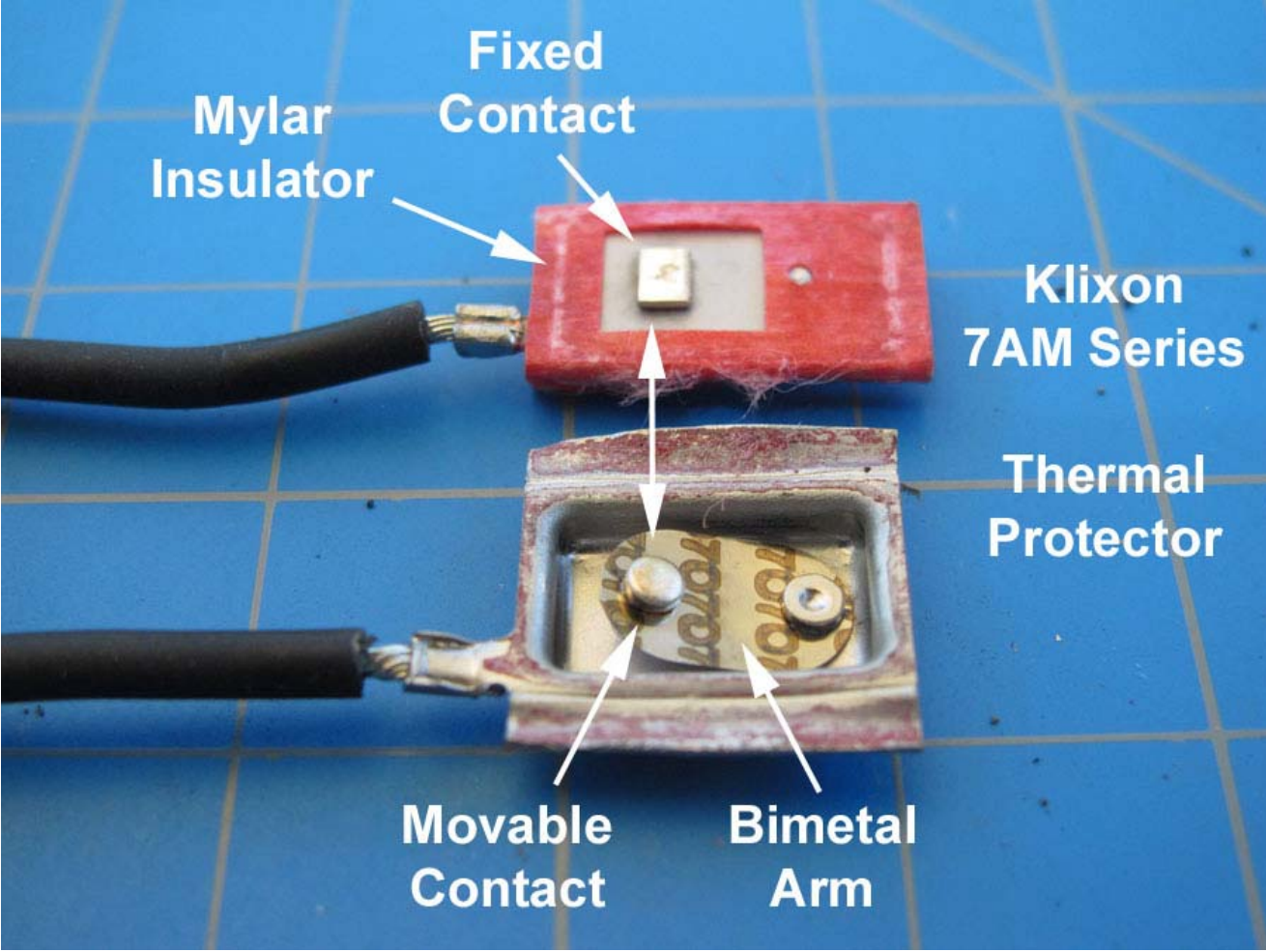



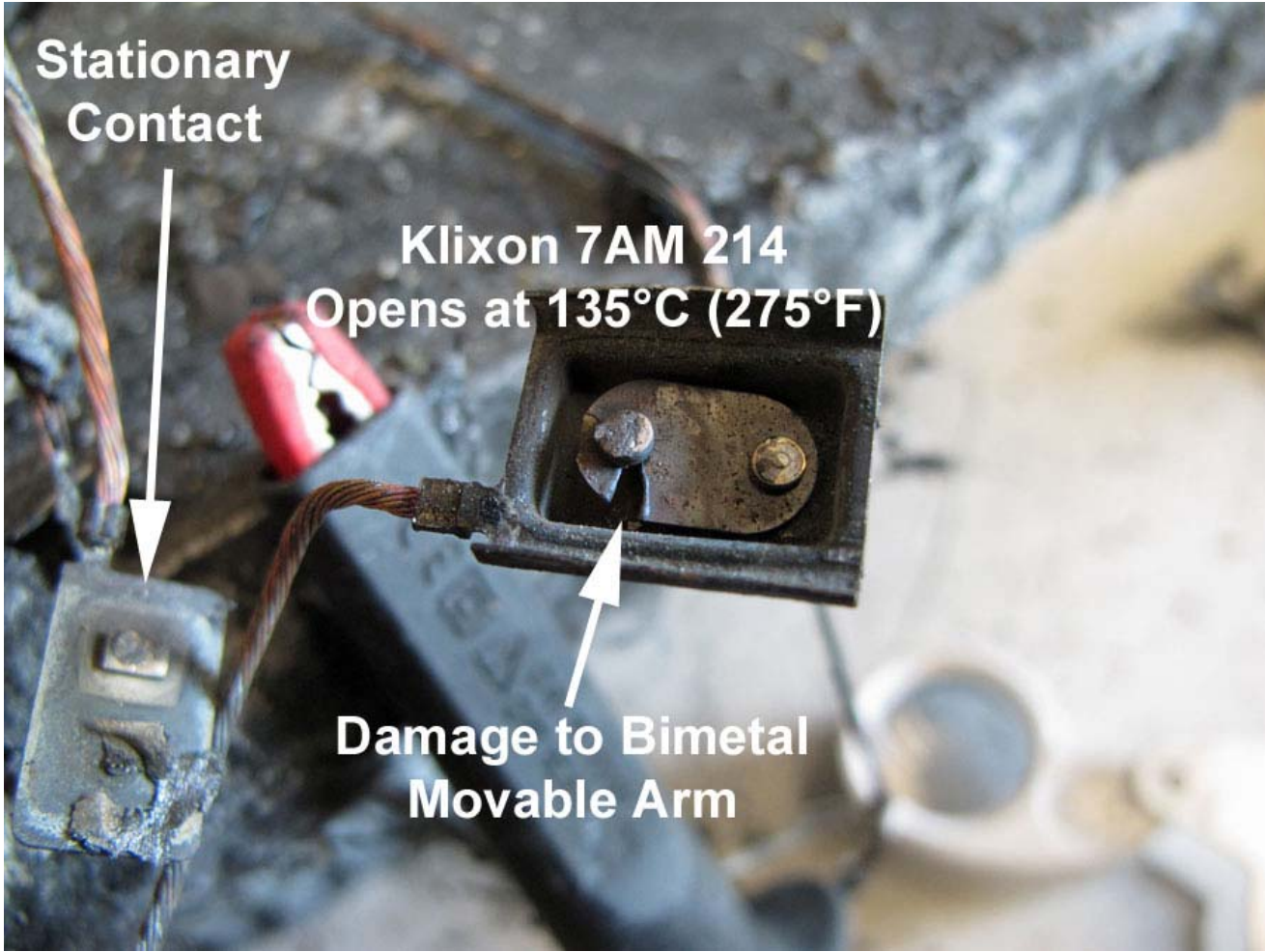

**Stationary  
Contact**

**Klaxon 7AM 214  
Opens at 135°C (275°F)**

**Damage to Bimetal  
Movable Arm**







**WARNING**

RISK OF FIRE OR ELECTRIC SHOCK  
DO NOT OPEN



**KITCHEN**  
SELECTIVES

MODEL : CM-316BL  
COFFEE MAKER  
120V~ 60Hz 900W



LISTED  
45ZN

HOUSEHOLD USE ONLY.

MADE IN CHINA

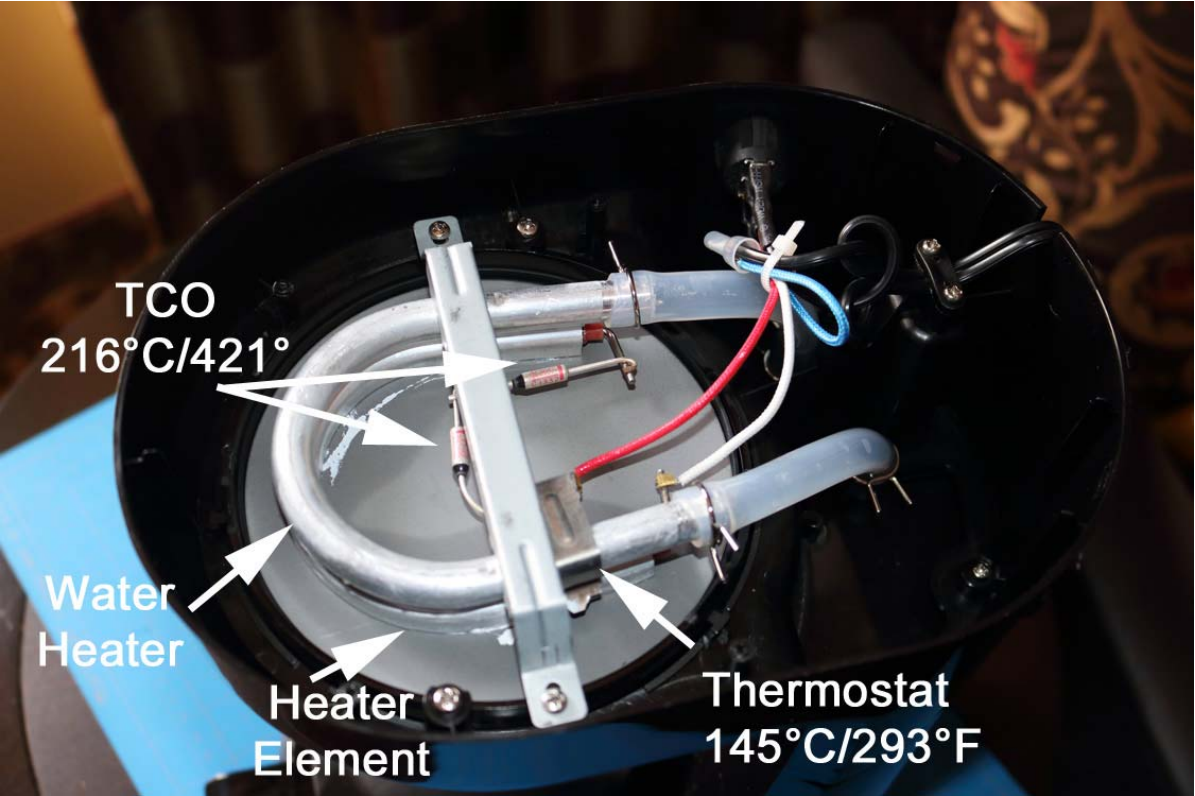







  
KSD301-G  
250V 10A  
125V 16A  
145

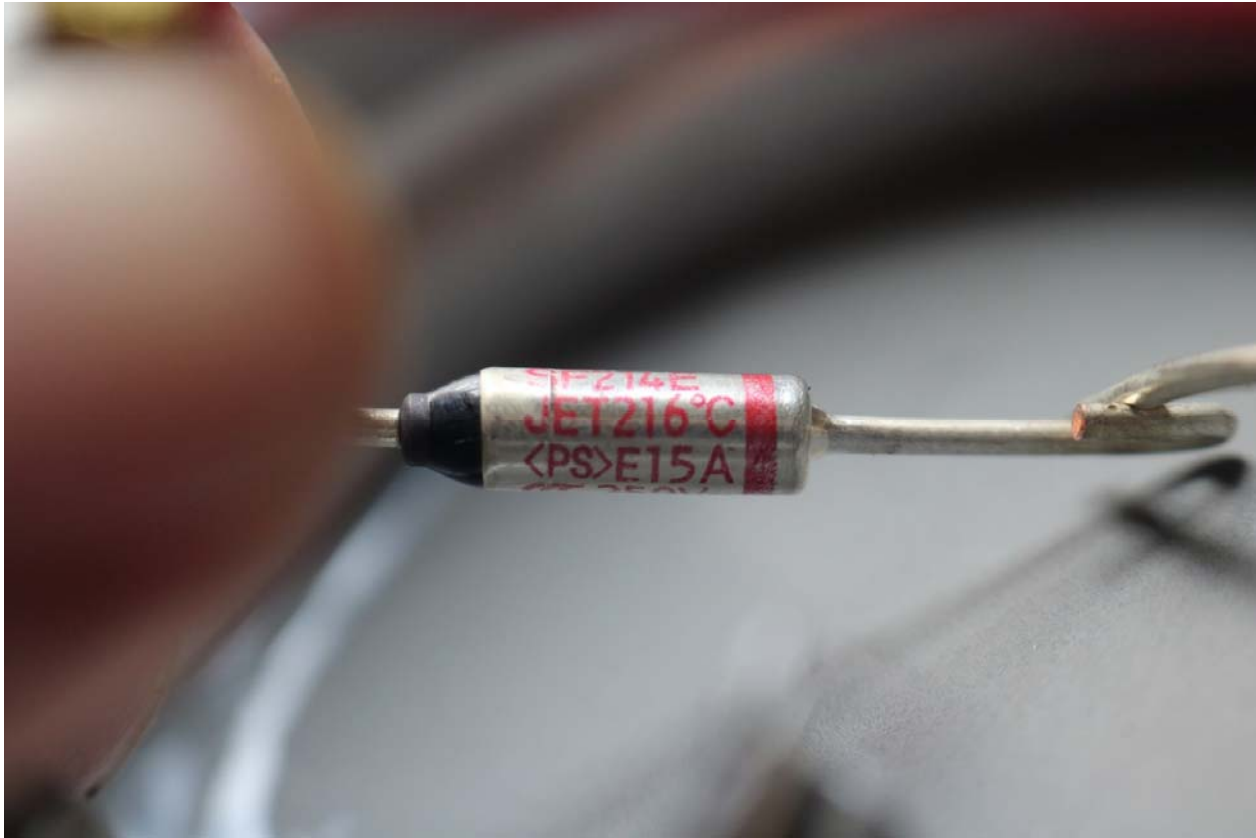









**Bottom View**

**Top View**

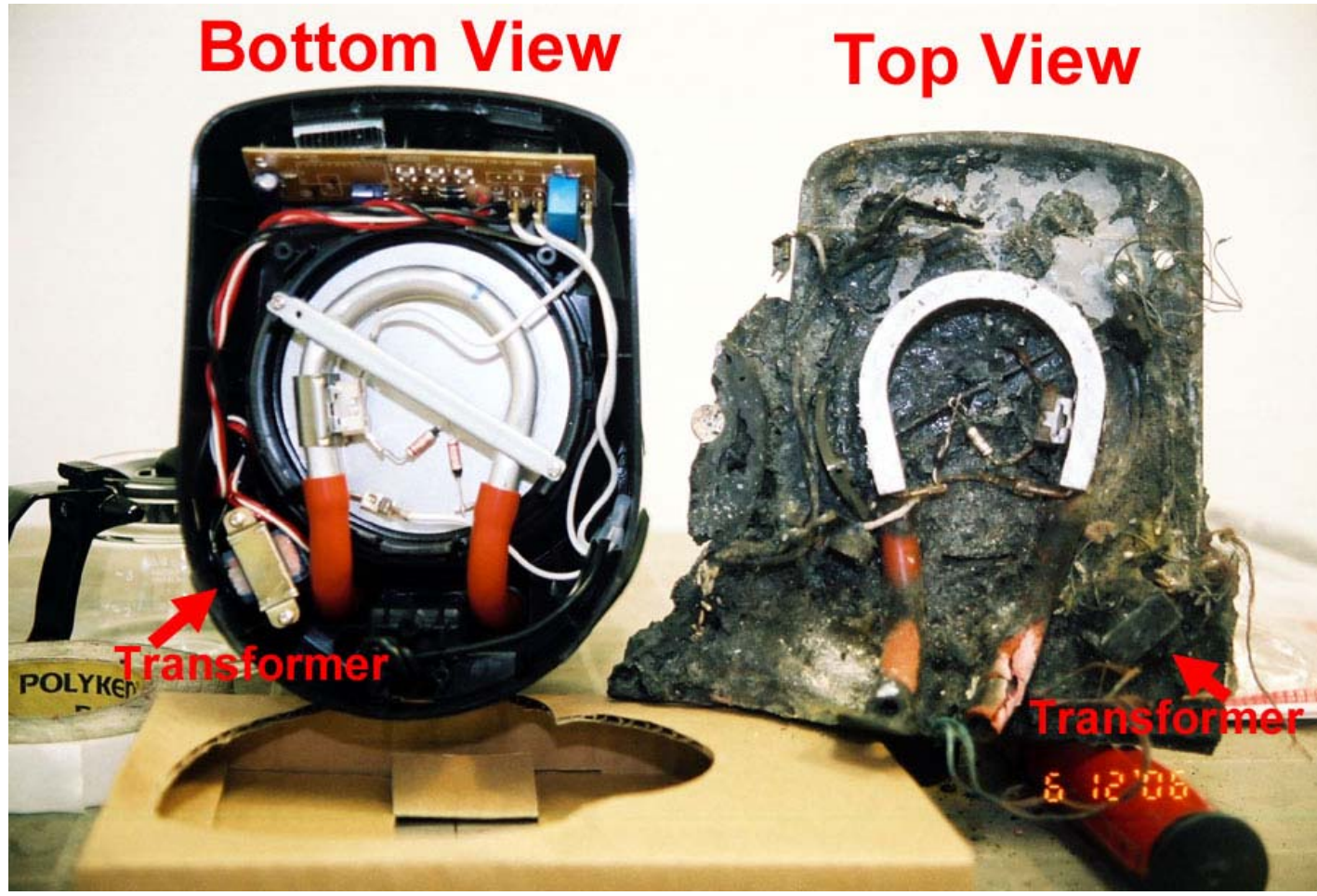









SILHOUETTE MODEL · SE1700  
STEAM IRON  
120V~ 60Hz 1200W



HOUSEHOLD USE ONLY  
DO NOT IMMERSE IN WATER

MADE IN  
CHINA

Intertek  
3022040





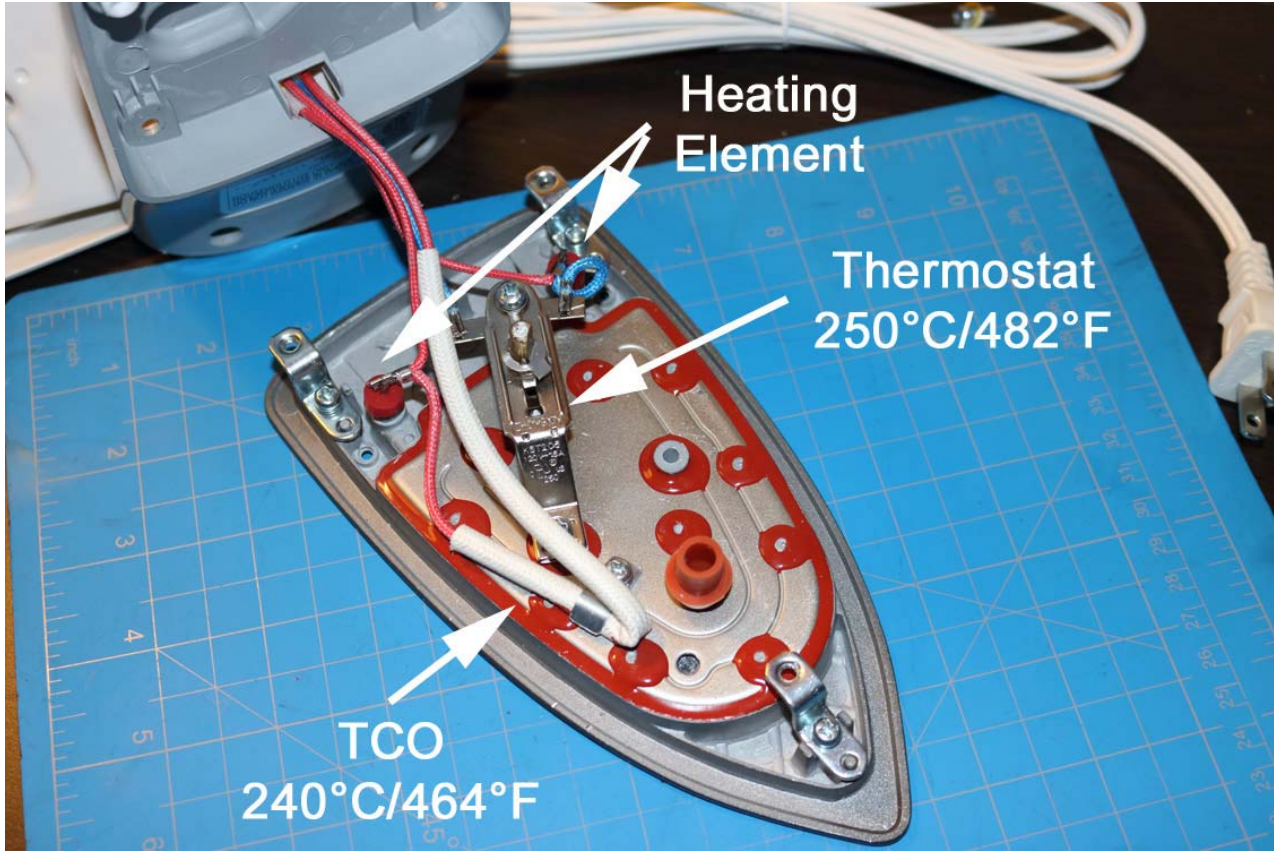

Heating  
Element

Thermostat  
250°C/482°F

TCO  
240°C/464°F

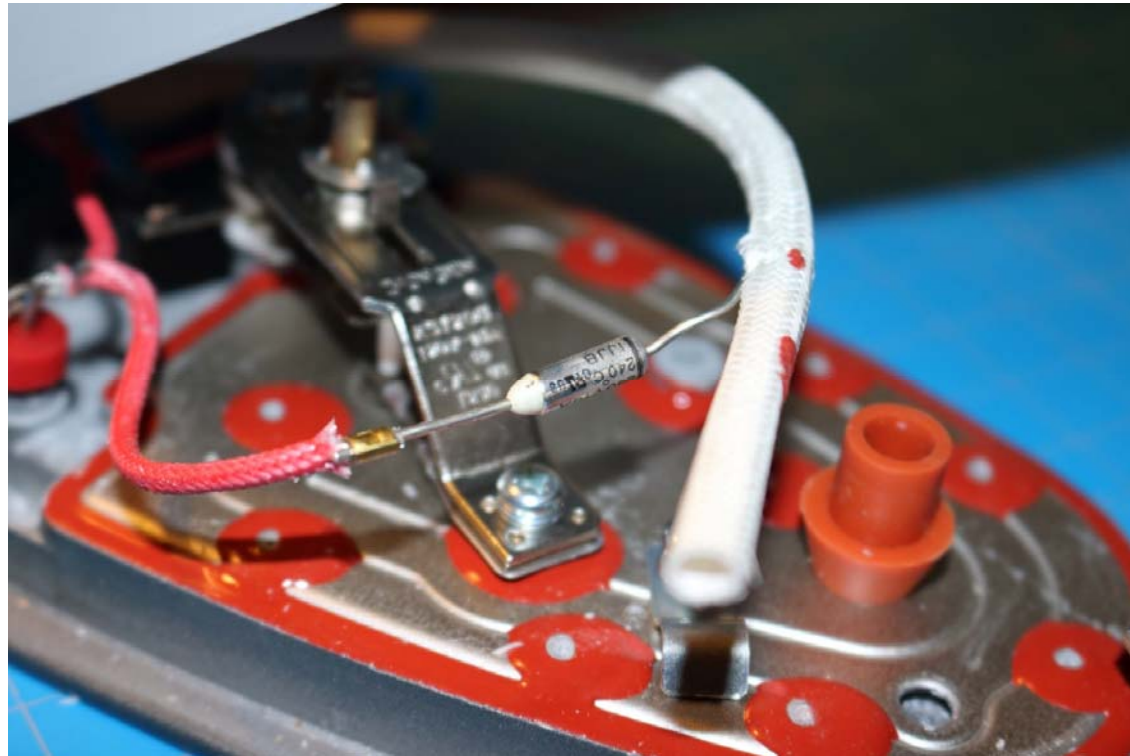















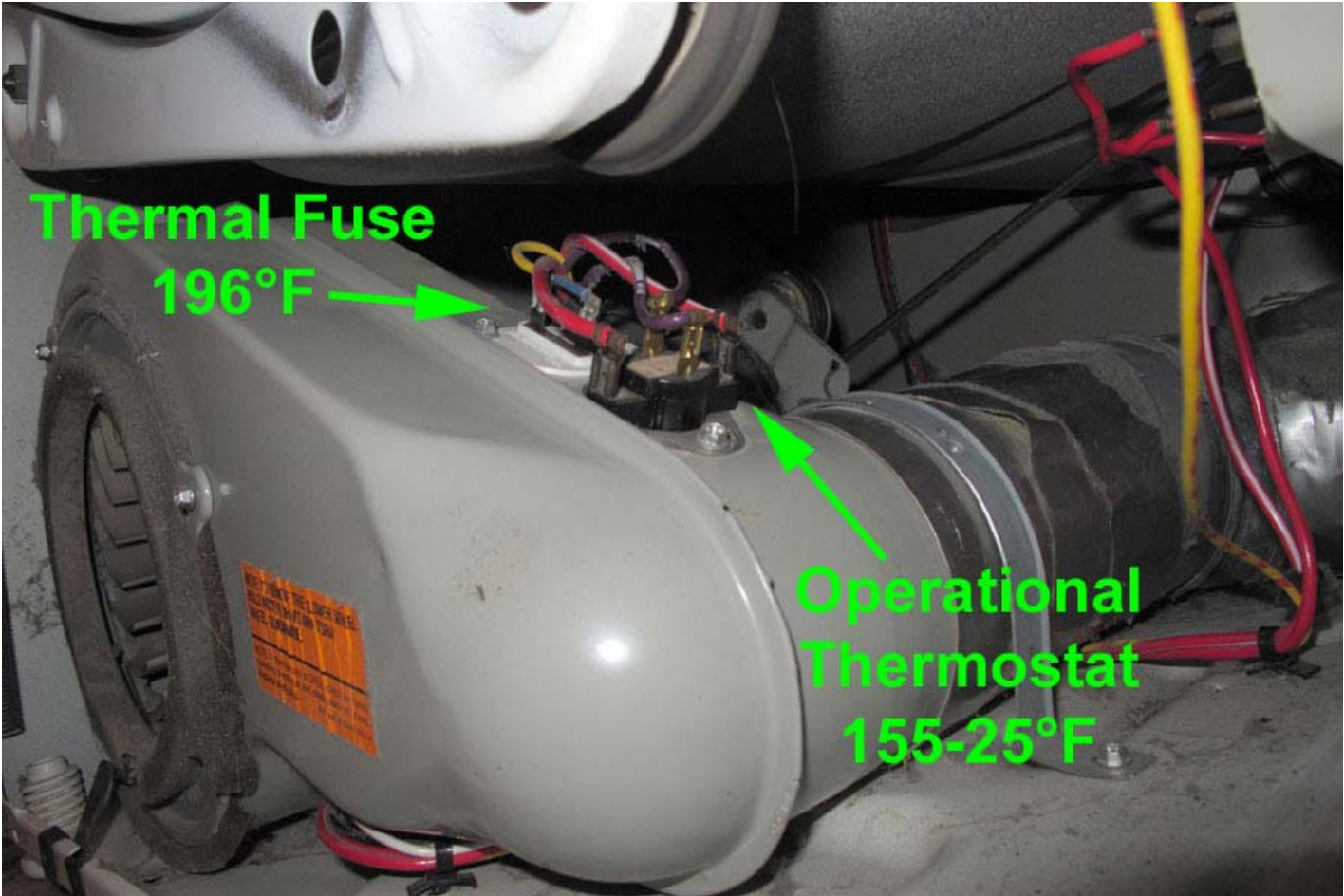

Thermal Fuse  
196°F

Operational  
Thermostat  
155-25°F



**Thermal  
Cutoff (fuse)  
350°F**

**High Limit  
Thermostat  
250-80°F**

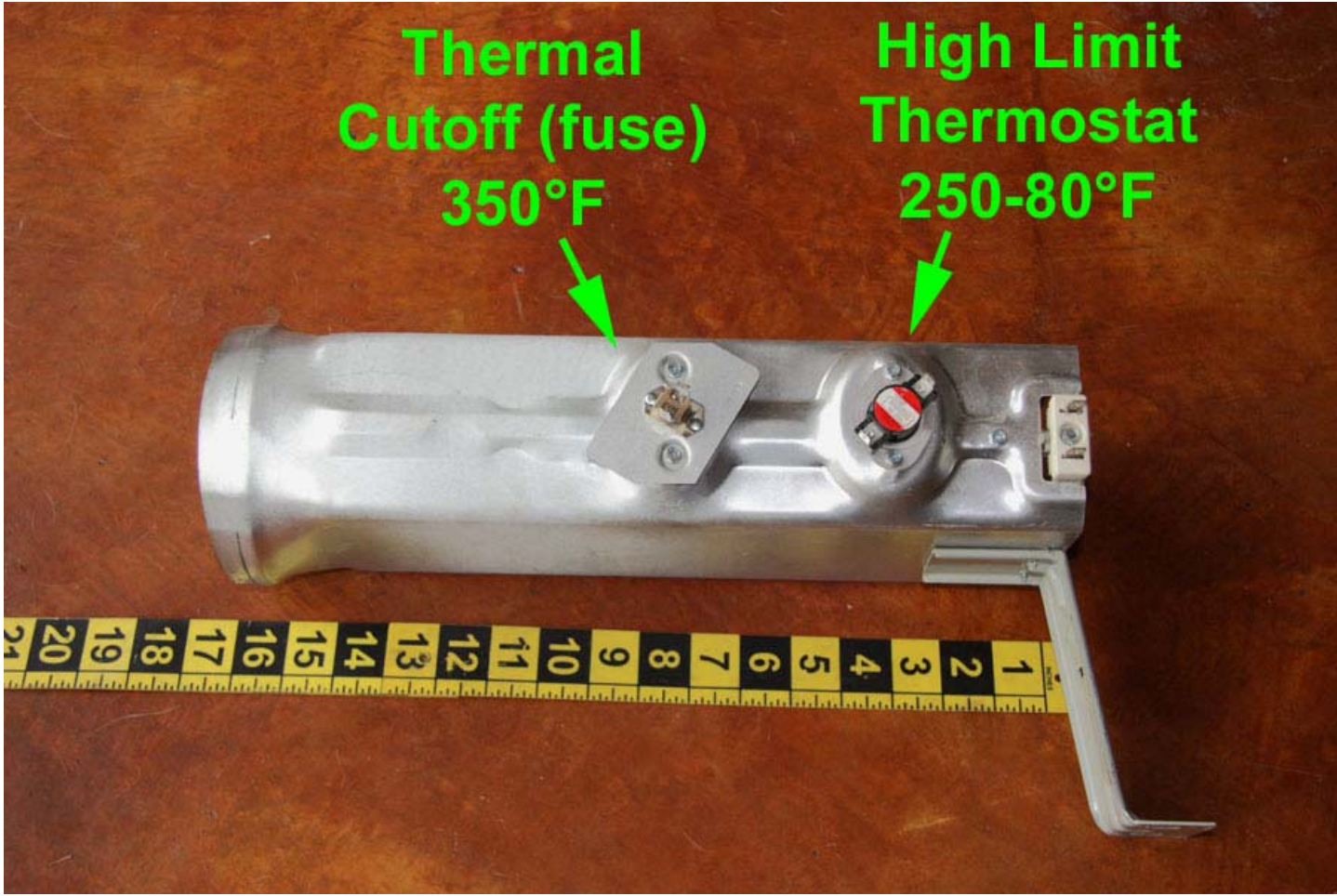

NOTE: If heater box thermal-cutoff is OPEN, change the thermal-cutoff and hi-limit thermostat by using the proper FSP® parts kit. In addition, check for failed heater, blocked or improper exhaust system and change failed parts.

Part No. 695080 Rev. B





Thermal  
Cutoff  
(fuse)

High  
Limit  
Thermo-  
stat







**Good Pads on Exemplar**

**Worn Pads on my  
High Limit Thermostat**

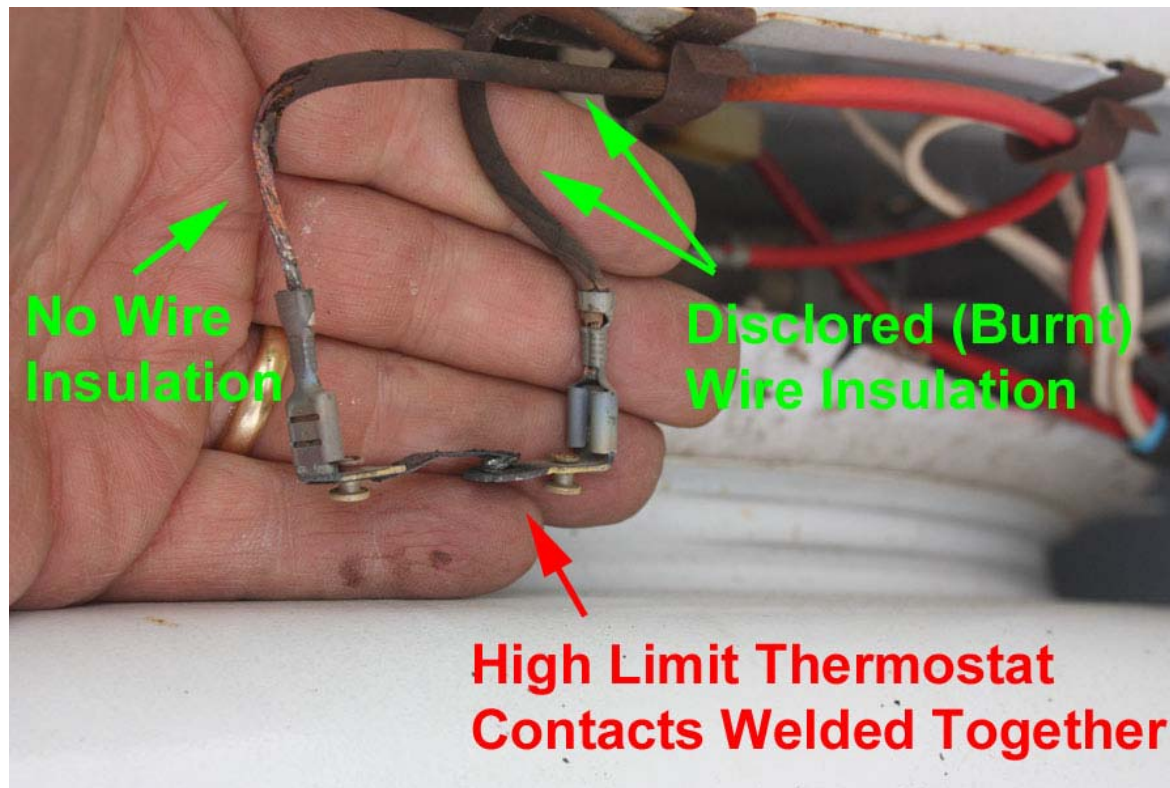

No Wire  
Insulation

Discolored (Burnt)  
Wire Insulation

High Limit Thermostat  
Contacts Welded Together

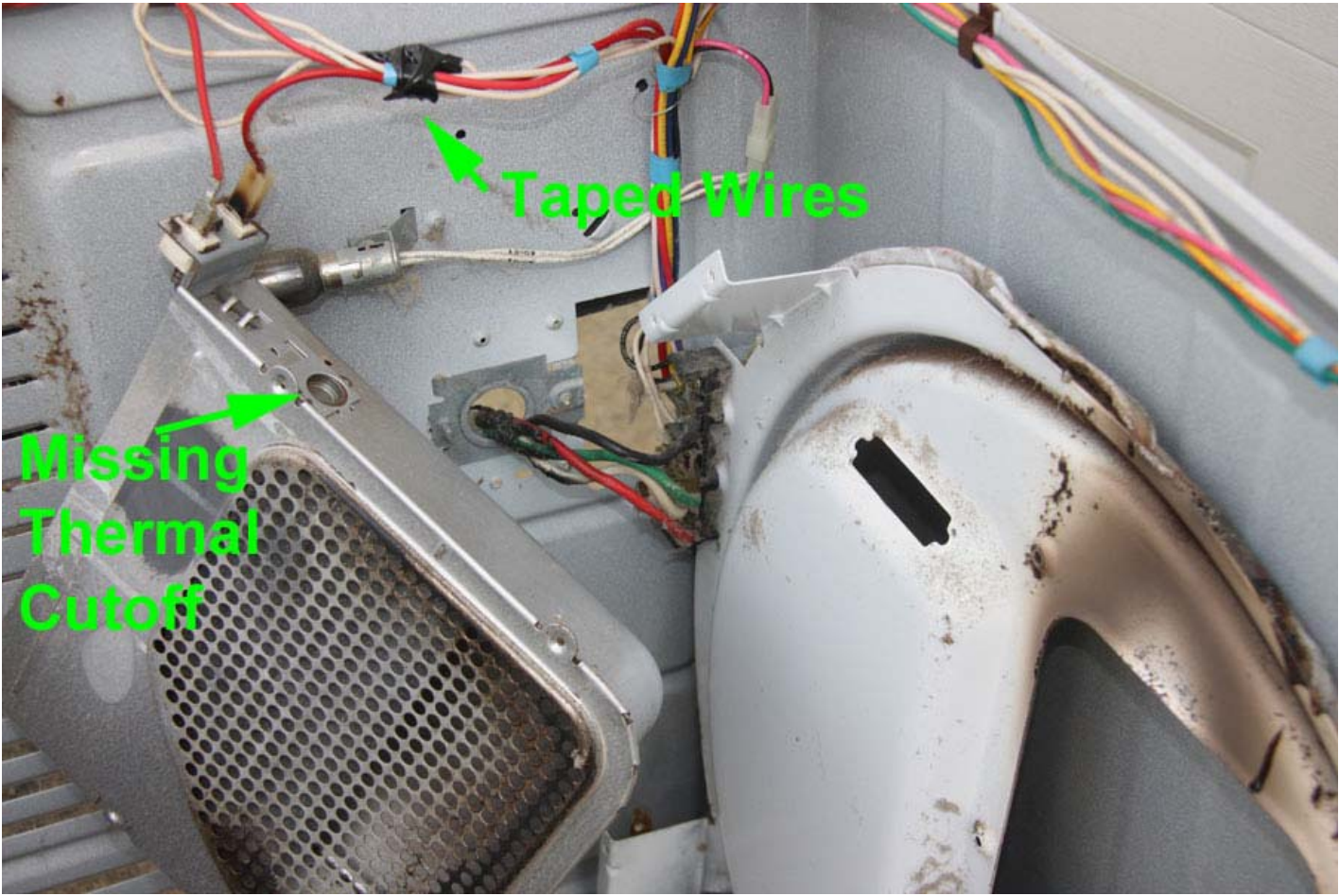

Taped Wires

Missing Thermal Cutoff



Thermal Cutoff  
Wires Jumpered

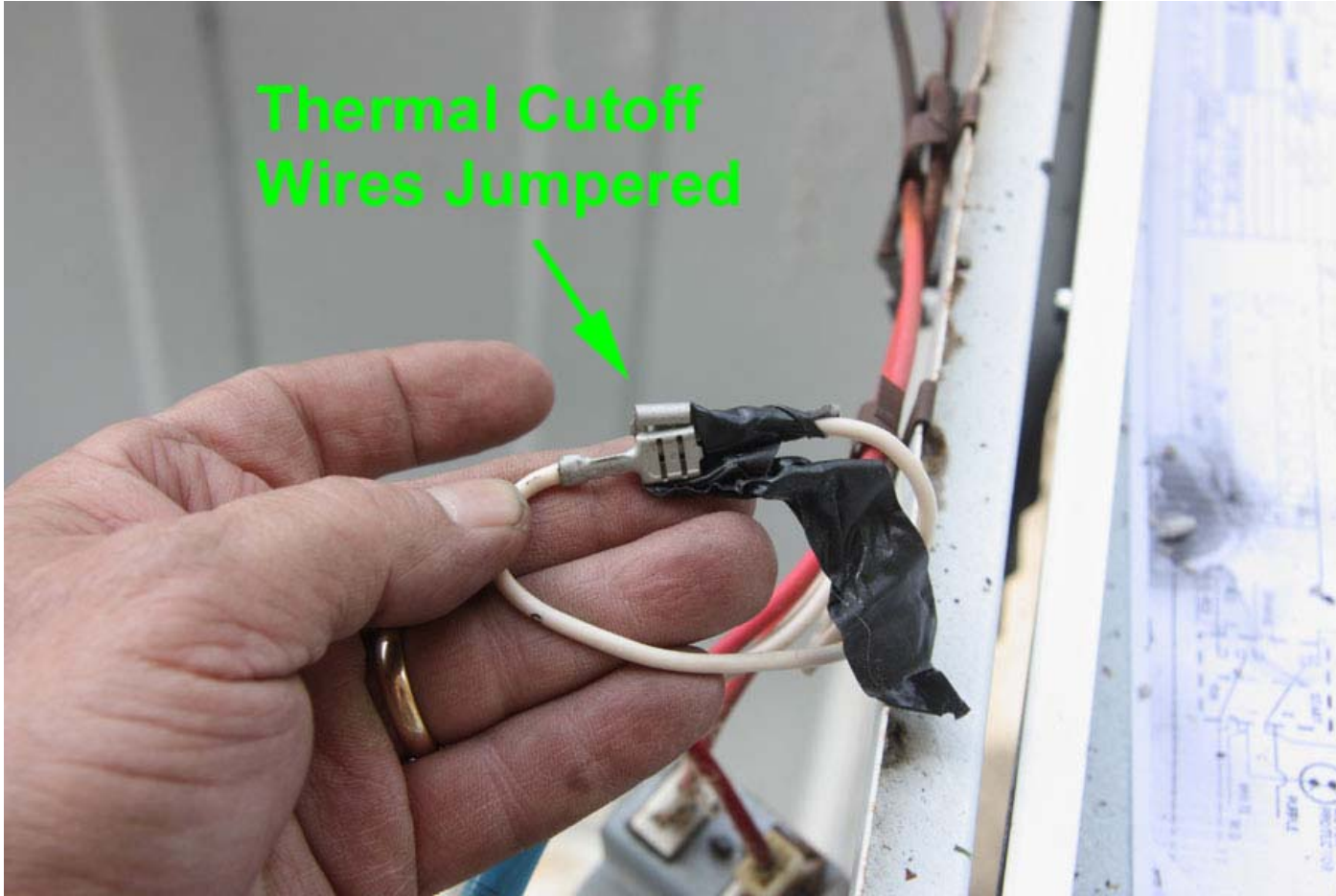



# Electric Heater



## **Safety Features**

### **Auto Safety Shut-Off**

Heater shuts off automatically in an overheat situation

### **Manual User Reset**

User must manually reset heater if it shuts off in an overheat situation

Prevents unintended operation after auto shut-off

### **Back-Up Overheat Fuse**

Provides additional overheat protection

### **Cool Touch Plastic Housing**

Allows for safe portability and placement almost anywhere in the room

### **Integrated Carry Handle**

### **Flame Resistant V2 Rated Plastics**

### **Experience**

Over 20 years of experience developing, engineering and testing heaters

## **RESET INSTRUCTIONS**

If the unit shuts down:

1. Turn MODE to OFF (○) and THERMOSTAT (⬆) to HI
2. Unplug unit, wait 30 minutes
3. Plug in and turn ON

## **INSTRUCCIONES VOLVER A ENCENDER**

Si la unidad se apaga sola:

1. Gire la perilla del Modo (MODE) (○) a la posición Apagado (OFF) y el Termostato (THERMOSTAT) (⬆) a Alta (HI).
2. Desenchufe la unidad y espere 30 minutos.
3. Enchufe y vuelva a encender.



# Electric Heater

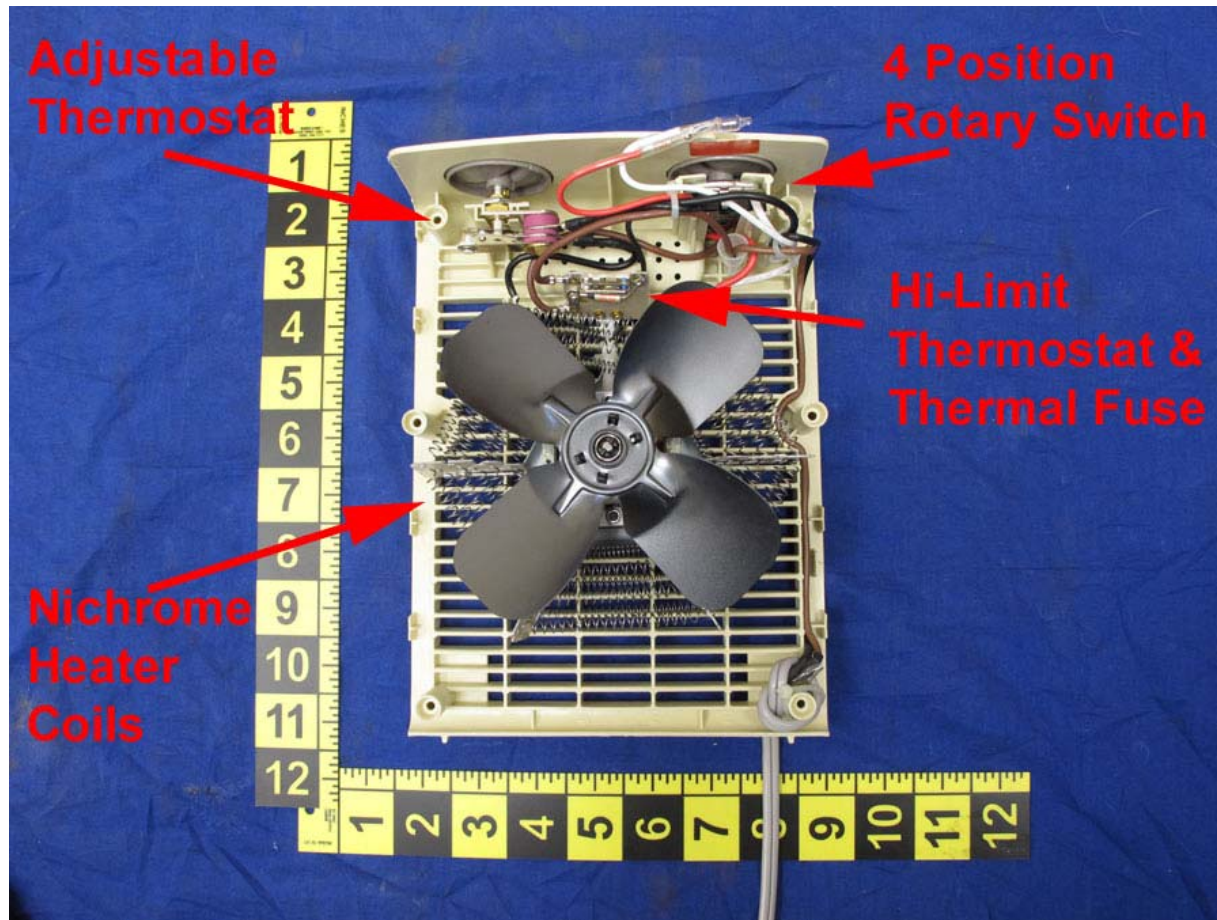



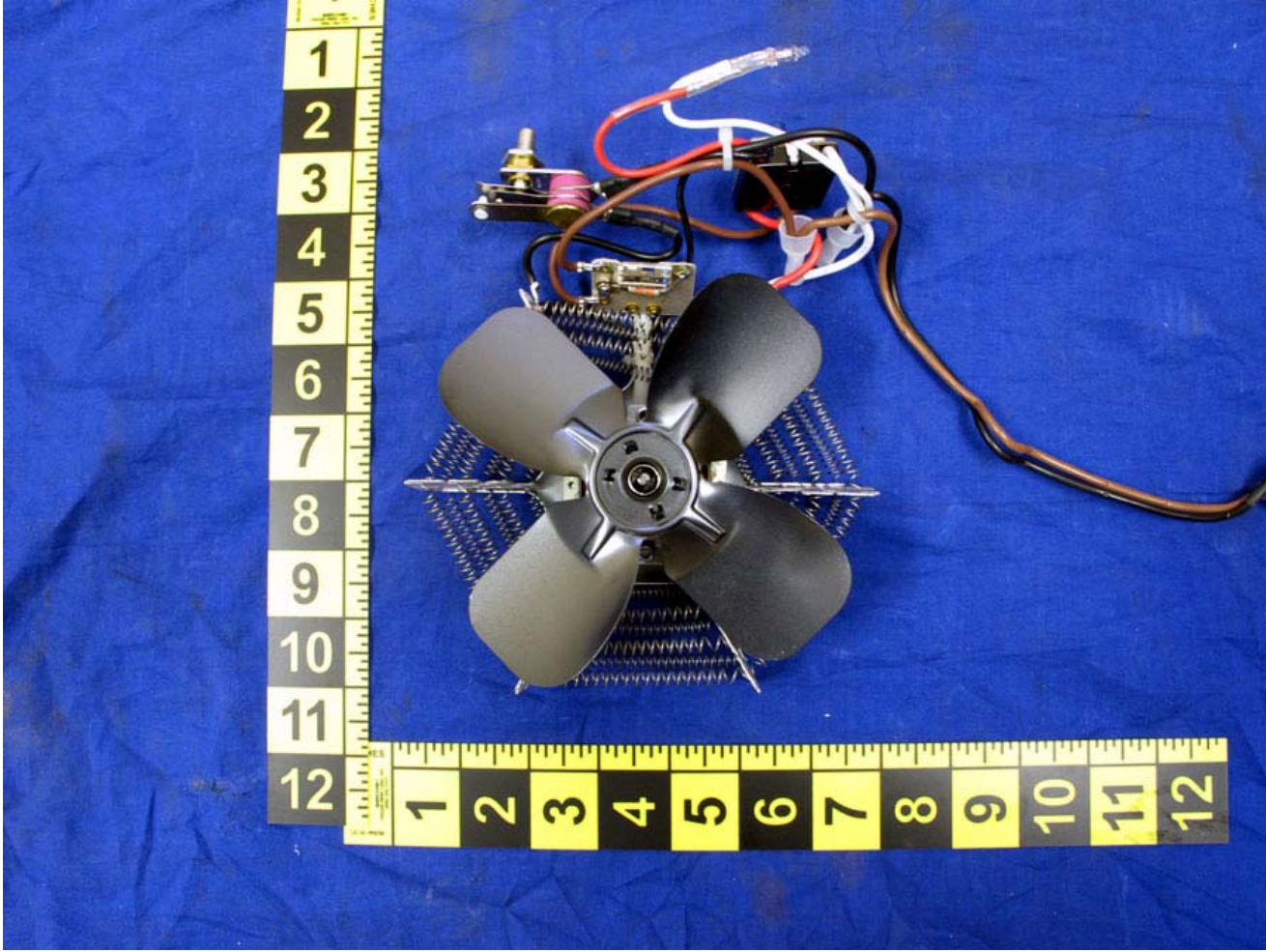

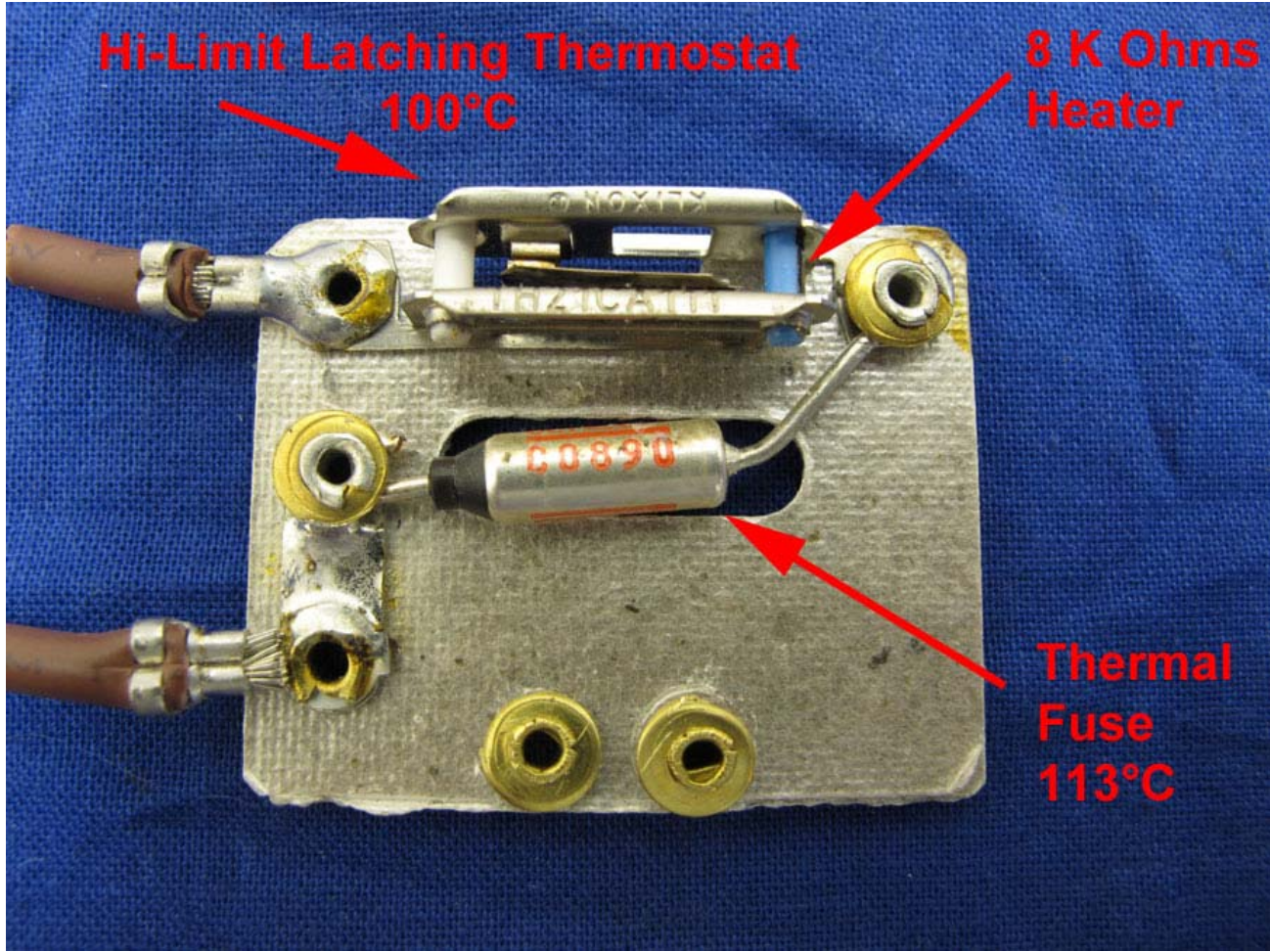

Hi-Limit Latching Thermostat  
100°C

8 K Ohms  
Heater

Thermal  
Fuse  
113°C

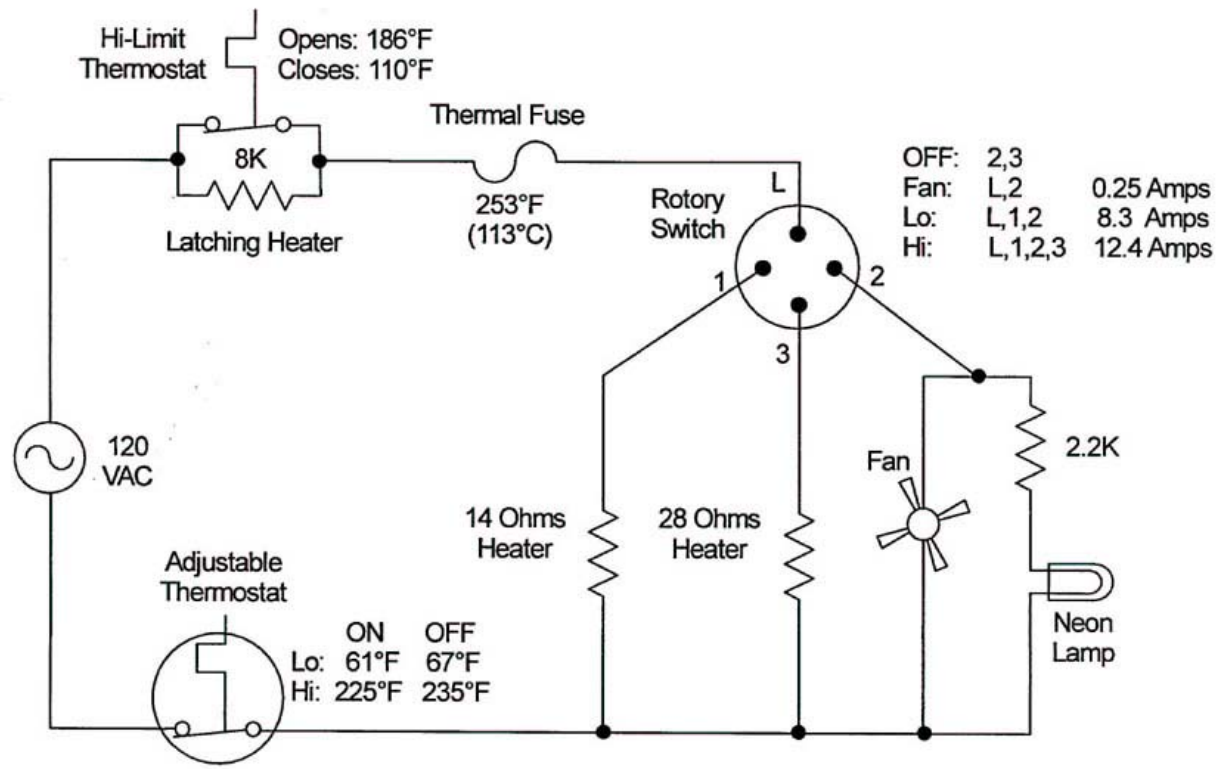















## UL-94 V-2 Plastic







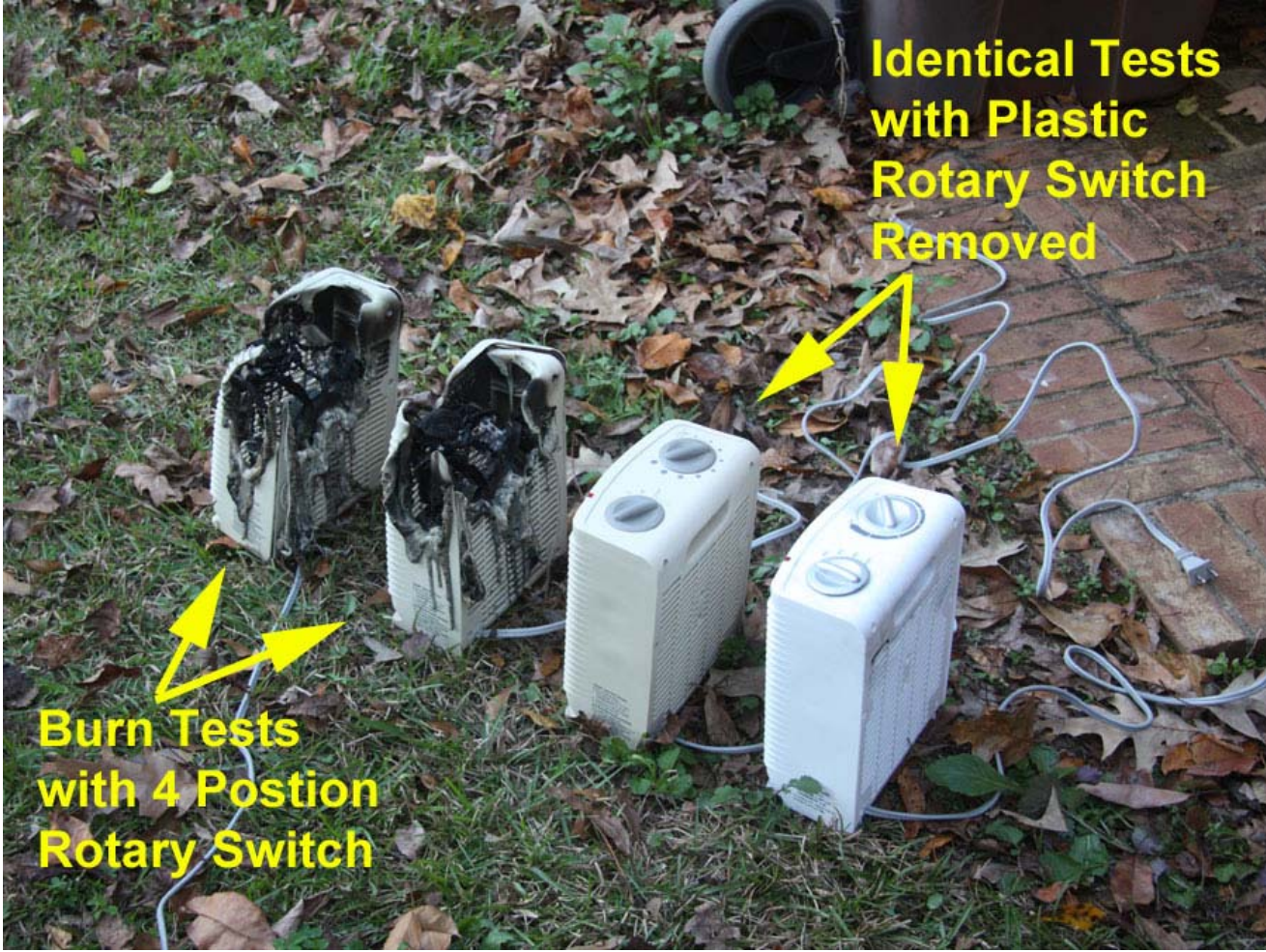

**Identical Tests  
with Plastic  
Rotary Switch  
Removed**

**Burn Tests  
with 4 Postion  
Rotary Switch**